

Plastic Volume Flow Rate Measuring Unit

Type VMRK

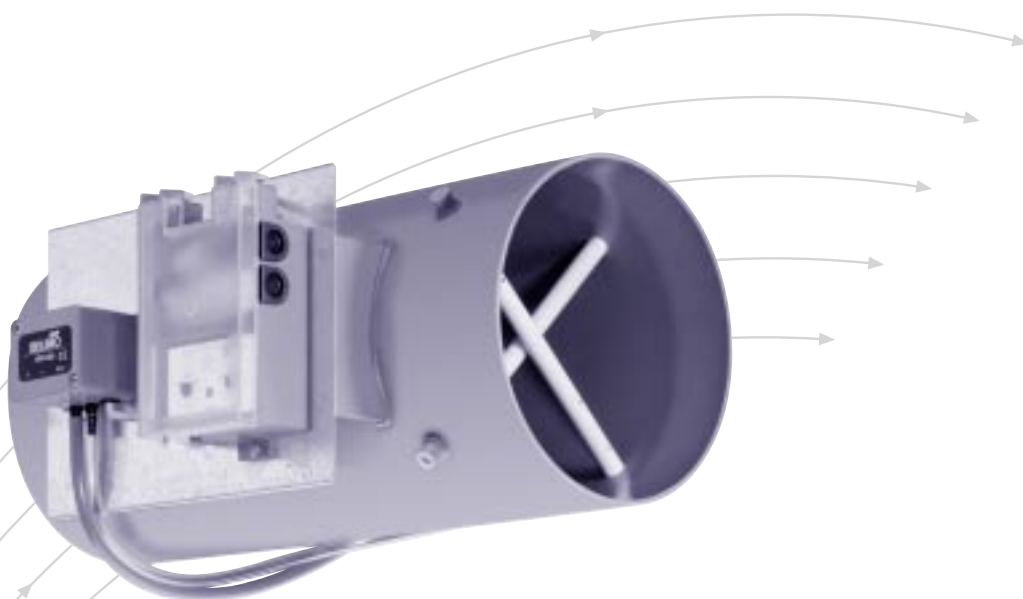

TROX[®] TECHNIK

TROX GmbH
Heinrich-Trox-Platz
D-47504 Neukirchen-Vluyn

Telephone +49/28 45/2 02-0
Telefax +49/28 45/2 02-2 65
e-mail trox@trox.de
www.troxtechnik.com

Description · Technical Data

Application

TROX plastic flowrate measuring unit, type VMRK is used for manual determination of volume flowrate or for continuous monitoring of the actual flowrate in ventilation ducts with air containing aggressive media. Because of its low pressure drop it is suitable for permanent installation in the ventilation ducts and is easily installed and dismantled. It should be noted that in critical cases a materials compatibility test, which takes account of aggressive substances and concentrations, must be carried out on the volume flowrate measuring unit and the diaphragm pressure transducer.

Description

The measuring unit consists of a circular casing and a differential pressure grid which provides the mean value for determining the volume flowrate. If requested pressure transducers can be fitted, wired and tubed at the factory.

Construction

Casing

- Circular construction
- Same connection diameter on both ends (basic construction)
- With optional flange both ends
- Connection nipple for tubing with $d_i = 6 \text{ mm}$

Volume flow rate measuring

- Manometer (by others) or with optional pressure transducer
- For supply and extract air
- Measurement accuracy $\pm 5 \%$ even with unfavourable supply and extract ducting arrangement
- Measured pressure differential range from 5 to approx. 250 Pa
- Pressure drop 15 % to 24 % of measured pressure differential



Installation conditions

Minimum straight duct length for supply and extract conditions

- | | |
|---|----|
| 1) Bend connection | 1D |
| Angle of sensor tubes must be at 45° to the bend centreline | |
| 2) Connection to main duct branch | 5D |
| 3) Reducing duct transformation | 2D |

Nomenclature

- | | | |
|------------------|------------------------------|--------------------------------|
| \dot{V} | in l/s or m ³ /h: | Volume flow rate |
| Δp_w | in Pa: | Measured pressure differential |
| ρ | in kg/m ³ : | Air density |
| Δp_g | in Pa: | Total pressure drop |
| $\Delta \dot{V}$ | in $\pm \%$: | Accuracy of measurement |

Technical data

Nominal size	$\dot{V}^3)$		C-value ¹⁾	$\Delta \dot{V}$ in $\pm \%$	$\Delta p_g^{2)}$ in %
	in l/s	in m ³ /h			
125	15- 150	54- 540	9.7	5	24
160	25- 250	90- 900	15.9	5	22
200	40- 405	144-1458	25.5	5	19
250	60- 615	216-2214	39.0	5	17
315	105-1025	378-3690	65.0	5	15

Highlighted values are nominal volume flow rates

- 1) At $\rho = 1.2 \text{ kg/m}^3$ related to l/s
 2) Of Δp_w
 3) Typical values

Volume flow rate measurement

The volume flowrate is calculated using the formulae:
with $\rho = 1.2 \text{ kg/m}^3$:

$$\dot{V} = C \cdot \sqrt{\Delta p_w} \quad \text{in l/s} \quad \dot{V} = C \cdot \sqrt{\Delta p_w} \cdot 3.6 \quad \text{in m}^3/\text{h}$$

for $\rho \neq 1.2 \text{ kg/m}^3$:

$$\dot{V} = C \cdot \sqrt{\Delta p_w} \cdot \sqrt{\frac{1.2}{\rho}} \quad \text{in l/s or m}^3/\text{h}$$

Dimensions in mm						
Nominal size	$\varnothing D_a$	$\varnothing D_1$	$\varnothing D_2$	s	$\varnothing d$	n ¹⁾
125	125	185	160	12	9	6
160	160	220	195	12	9	8
200	200	260	235	12	9	10
250	250	310	285	15	9	10
315	315	375	350	15	9	12

1) n = Number of flange holes

Example

Given: Nominal size 160
C-value = 15.9 (from table page 2)
 $\Delta p_w = 100 \text{ Pa}$
(reading from manometer)

Required: Volume flow rate \dot{V} in l/s or m³/h
at $\rho = 1.2 \text{ kg/m}^3$

Calculation: $\dot{V} = 15.9 \cdot \sqrt{100}$

Result: 159 l/s or 572 m³/h

Weight in kg		
Nominal size	VMRK	VMRK-FL
125	0.6	0.9
160	0.7	1.2
200	0.9	1.6
250	1.2	2.0
315	1.5	2.8

Standard construction

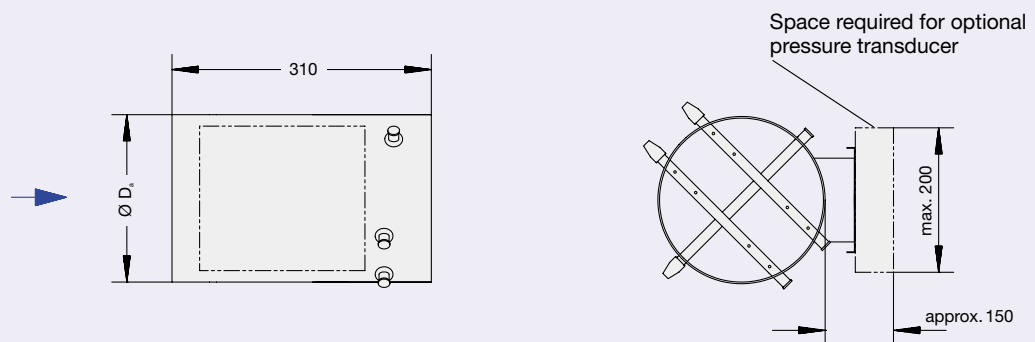

With flange

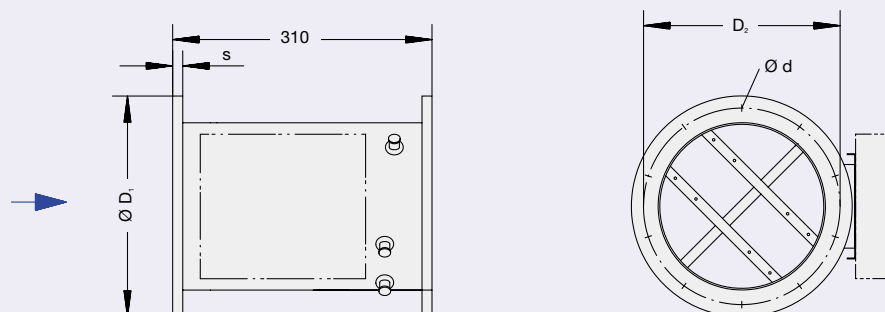

Order Details

Specification text

Plastic flow rate measuring unit for manual determination of volume flow rate or for continuous monitoring of the actual flow rate in ventilation ducts with aggressive media. Consists of circular casing and averaging differential pressure sensor grid and factory fitted and pre-wired optional static pressure transducers. Same connection diameter both ends with optional flanges. Measurement accuracy $\pm 5\%$ even with unfavourable supply and extract ducting arrangement. Pressure drop 15 & to 24 % of measured pressure differential, depending on size.

Materials:

Flame retardant polypropylene housing (PPs), and polypropylene (PP) sensor grid.

Order code

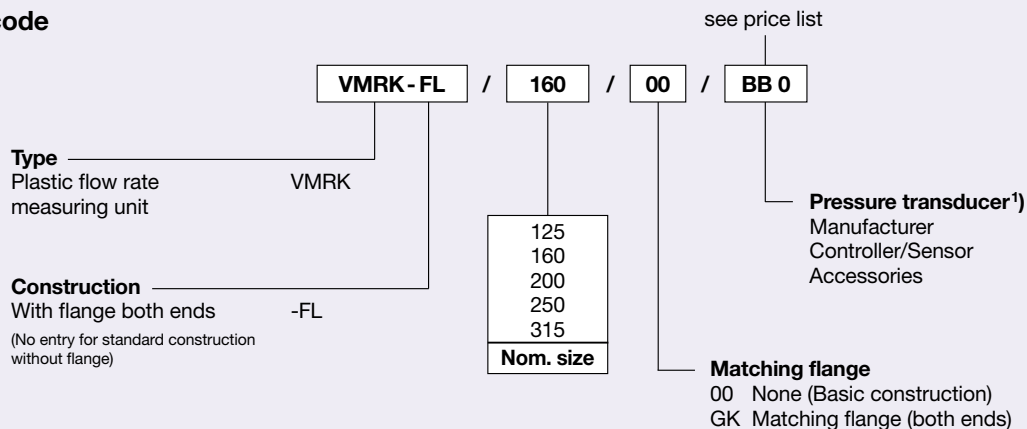

1) No entry for measuring units without pressure transducer

Order example

Make: TROX
Type: VMRK - FL / 160 / 00 / BB 0