

# Acoustic Louvres

Type NL

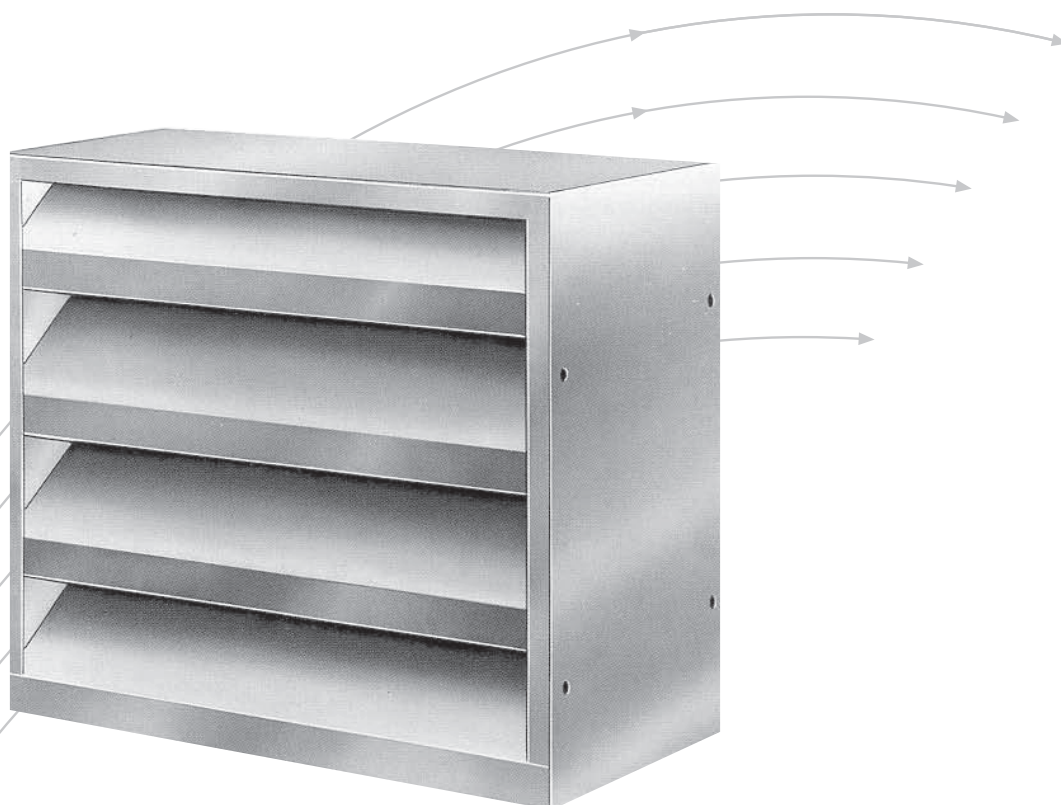

**TROX<sup>®</sup> TECHNIK**

• TROX Malaysia Sdn. Bhd.  
• 20 Persiaran Bunga Tanjung 1  
• Senawang Land Industrial Park  
• 70400 Seremban  
• Negeri Sembilan Darul Khusus  
• Malaysia

Telephone + 606-678 8188  
Telefax + 606-678 8288 / 388  
E-mail [enquiry@troxapo.com](mailto:enquiry@troxapo.com)  
[www.troxapo.com](http://www.troxapo.com)

# Contents · Description

Description _____	2	Louvre Selection · Nomenclature _____	7
Standard Louvres · Construction · Sizes _____	3	Acoustic Performance _____	8
Modular Construction · Optional Features _____	4	Pressure loss · Regenerated noise _____	9
Penthouse Louvres · Construction · Sizes _____	5	Order details _____	10
Installation _____	6		

## Type NL

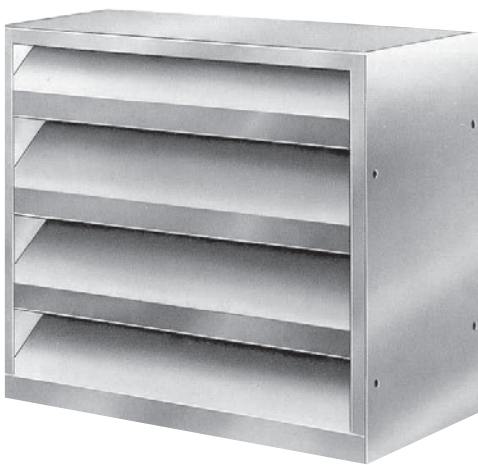

The TROX Type NL acoustic louvre provides a positive solution where noise attenuation is required from a weather louvre. This type of louvre is available in either steel or aluminium construction for both 'standard' and 'high' acoustic performance options. A non-acoustic version is also available to complement these two options to provide a consistent visual external appearance.

# Construction · Dimension

## Product Range

### Type NL

Standard acoustic performance louvre.

### Type NLH

High acoustic performance louvre comprising of two units Type 'NL' louvers mounted together back to back.

### Type NLD

Non-acoustic weather louvre with complementary external visual appearance.

## Steel Construction

Casings are manufactured from 1.5mm thick galvanised sheet metal channels. Casing sides are pre-slotted for fixing to builder's opening and any adjacent louvre sections. Galvanised louvre blades are of aerodynamic section and are set at approx. 40° on 150mm pitches. A raised lip is incorporated at the rear of the blade to minimise rain ingress. Bird screens from 12 x 12 x 1mm galvanised wire mesh are fitted as standard to all types, except Type NLD when fitted with blanking plate.

Acoustic louvre blades contain infill which complies with Class O Building Regulations. The infill has a glass cloth facing and is contained behind expanded sheet steel. This dual protection prevents damage and fibre erosion up to 20 m/s airway velocity.

## Aluminium Construction

Construction is generally as for steel types described above except that casing and louvre blades are made from aluminium sheet with expanded aluminium sheet to retain the infill material.

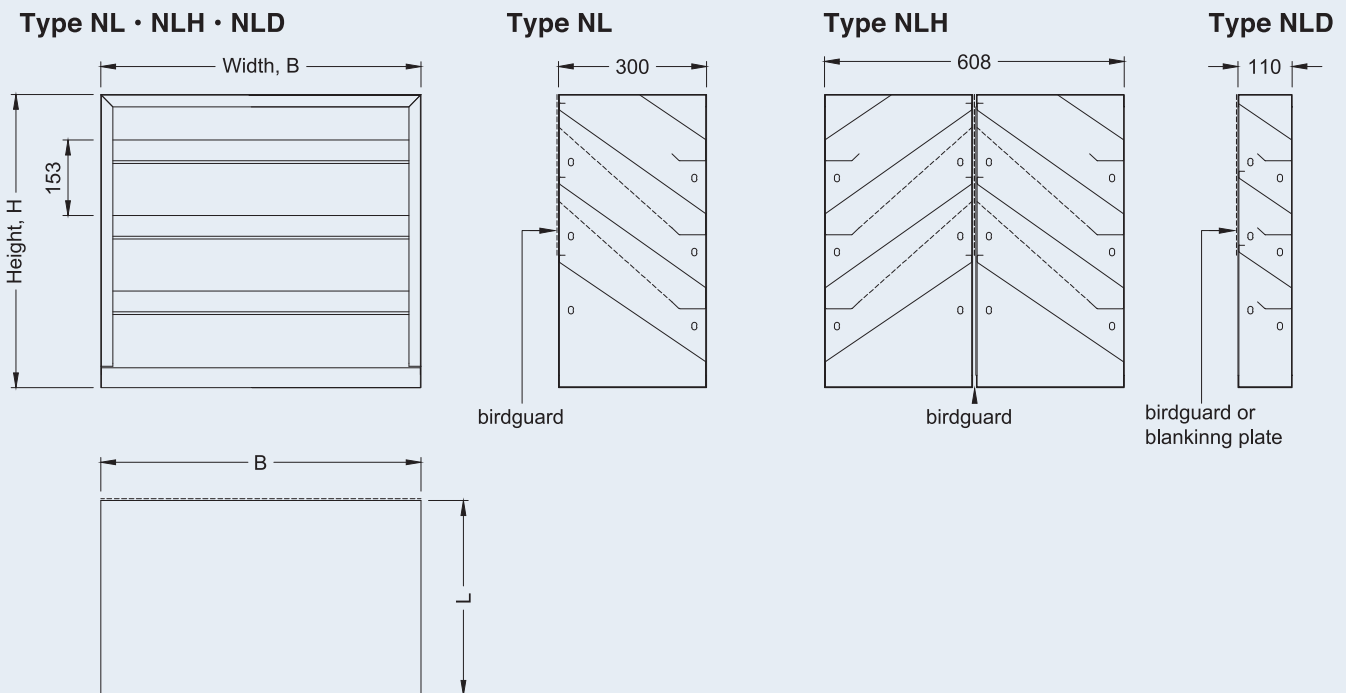

Louvre Type	Approximate Weights
NLS	48 kg/m <sup>2</sup> face area
NLA	35 kg/m <sup>2</sup> face area
NLH	as NLS or NLA x 2
NLD	as NLS or NLA x 0.5

Dimensions in mm	Standard Sizes
B	300 → 1800 in increments of 150
H	450 → 2400 in increments of 150

# Modular Construction · Optional Features

## Modular Construction

Acoustic louvre are normally supplied in modules when either of the following dimensions is exceeded :

$B = 1800\text{mm}$      $H = 2400\text{mm}$

The assembly of modules louvre is on site, by others. Where louvres are in modules both width and height, a 50x50x3 galvanised vertical box section frame is supplied to couple together adjacent sections. The weight of the upper section is borne by the coupling frame and not by the lower louvre. Coupling frames are concealed behind a cover plate of material and finish to complement the louvre.

The combinations illustrated below are available in louvre Types NL, NLH and NLD.

1. Split on width only.
2. Split on width and height.
3. Split on height only.

## Optional Features

Louvres can be supplied with matching sheet metal architrave or rolled metal angle picture frame. These would be supplied loose and undrilled for site fixing by others.

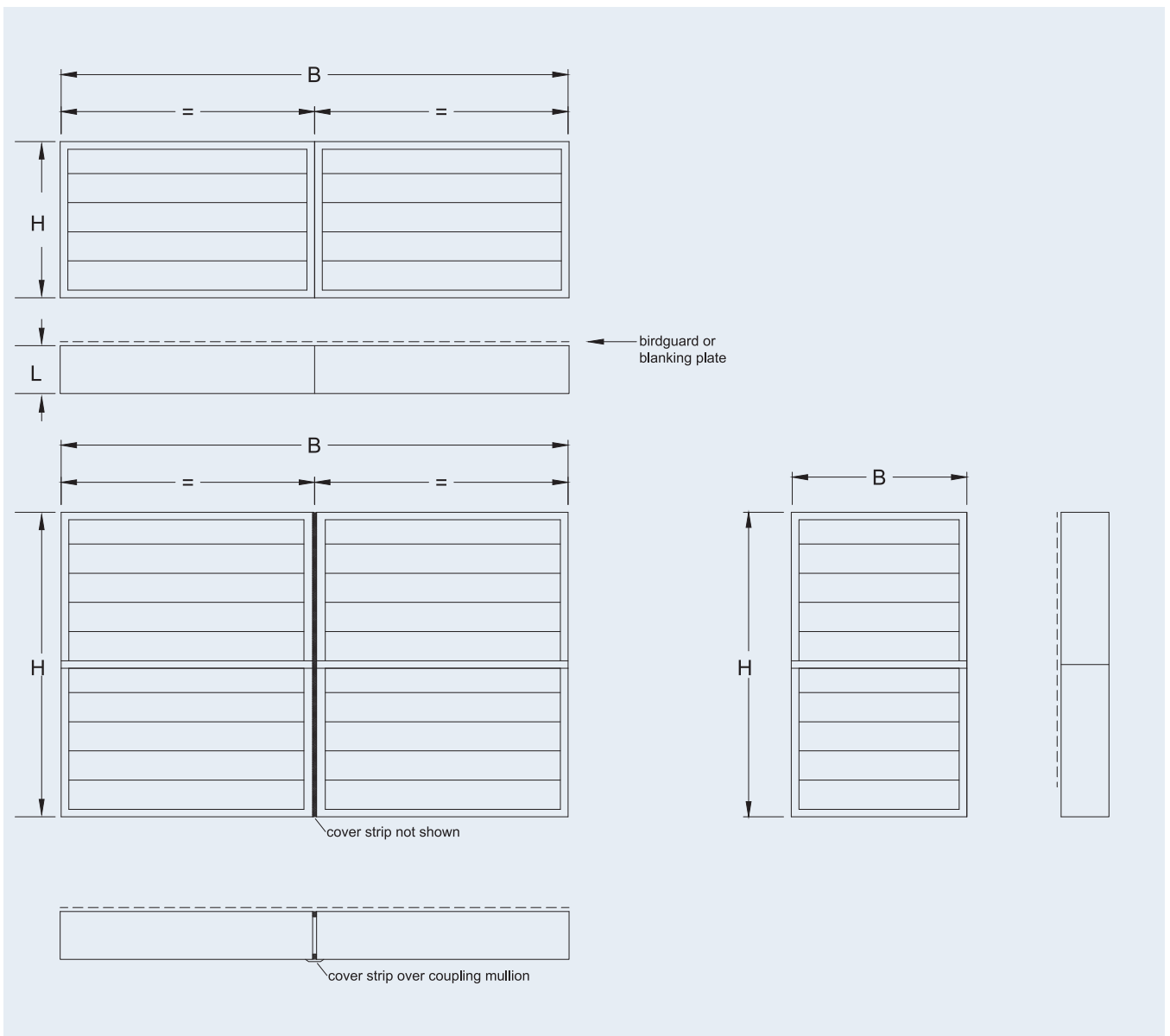

# Penthouse Louvres · Construction · Sizes

## Type NLP NLHP

Acoustic Penthouse Louvre comprising a four sided enclosure utilising standard acoustic louvre Types NL or NLH, as described on page 3.

The sheet metal roof and corner sections are constructed from 1.2mm thick material. The roof is provided with a slope or pitch (according to size) to prevent water collection.

An acoustic 'ceiling' panel is inset at the top of the louvres. The 50mm thick panel is manufactured from 1.2mm thick sheet metal and incorporates Class O erosion protected acoustic infill retained behind expanded sheet metal.

Penthouse Louvres are normally supplied as a kit of loose parts for site assembly by others.

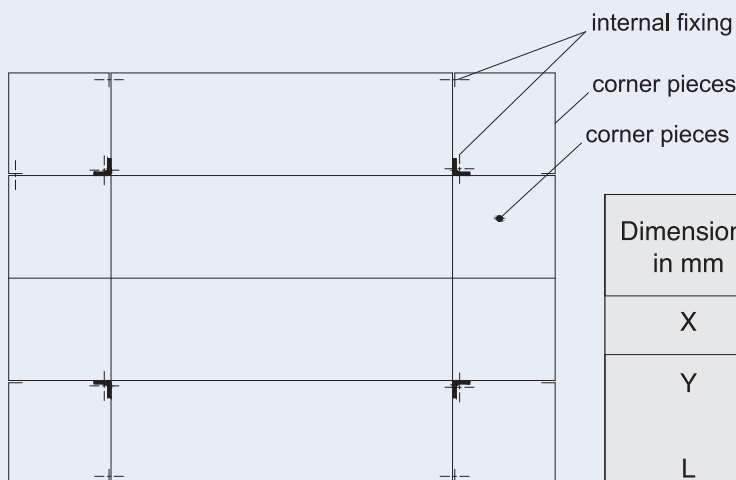
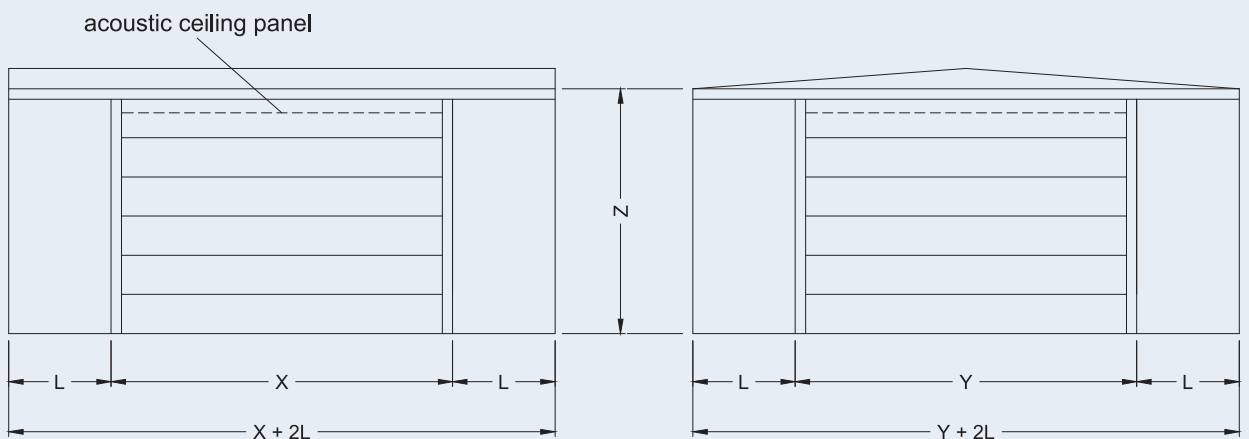

Dimensions in mm	Standard Sizes
X	450 → in increments of 150
Y	450 → in increments of 150
L	300 Type NLP 608 Type NLHP
Z	450 → in increments of 150 It is recommended that dimension Z does not exceed X or Y.

# Installation

## Type NL · NLH · NLD

### Installation Details

The vertical casing sides of the acoustic louvres are pre-slotted to facilitate fixing using a variety of acceptable methods. Where supplied, architraves and picture frames are supplied loose and undrilled.

On multisection units incorporating hollow section coupling frames, the frames are supplied drilled for easier site assembly. During fixing, the louvres should be set square and true in opening then wedged before fixing. Air gaps should be filled with a flexible mastic.

Installation and fixing items are not normally supplied; however, screws would be provided for use with our standard vertical box sections frames, where supplied.

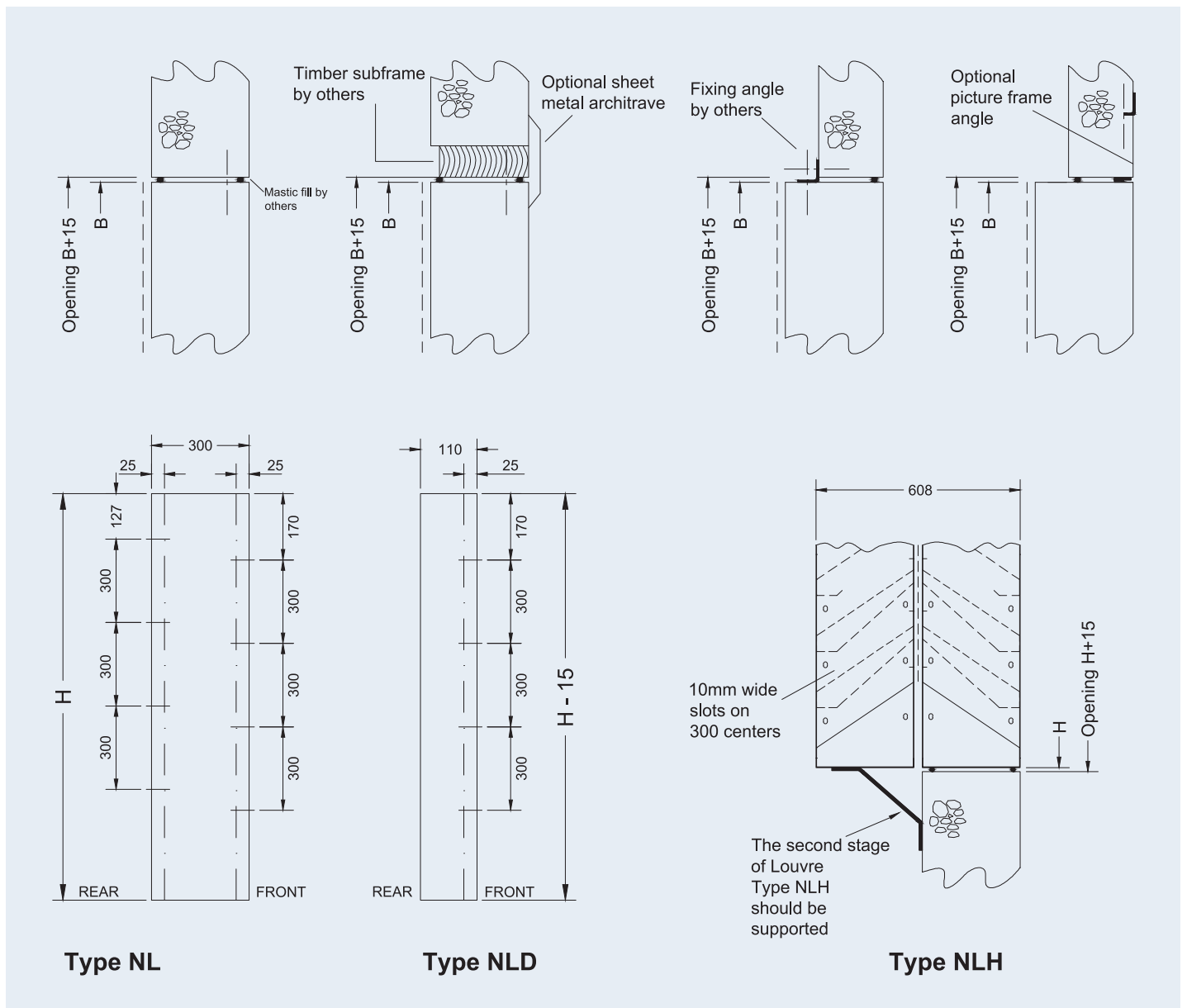

# Louvre Selection · Nomenclature

## Louvre Selection

The acoustic performance needed to meet a particular design noise requirement can be calculated from TROX leaflet entitled 'Sound & Sense' and other technical sources. Table 1 indicates the acoustic performance available from standard and high performance acoustic louvres.

From Table 2, select a louvre size at a face velocity that gives an acceptable pressure loss. Check that louvre self-noise will not infringe upon the design noise criterion by reference to the Self Noise Index, SNI.

The SNI gives an approximation of regenerated noise from the louvre due to air velocity. This is expressed as an NC value at 1 metre, 3 metres and 10 metres from the louvre face. The louvre selected should have an SNI at least 5 NC below the design noise criterion.

### Nomenclature

L	in mm	: Length, in direction of airflow.
B	in mm	: Width.
H	in mm	: Height.
$\dot{V}$	in l/s	: Volume flow rate.
$v_f$	in m/s)	: Face velocity based on $V \div (B \times H \times 1000)$
$\Delta p$	in Pa	: Pressure Loss.
$f_m$	in Hz	: Octave centre frequency.
SRI	in dB	: Sound Reduction Index
SNI		: Self Noise Index; equivalent to NC sound pressure level curve at free field distance show.

### Example

a) SRI required @  $f_m =$

125	250	500	1k	2k	4k	Hz
1	5	7	11	14	12	dB

b) Design noise criterion = NC45 at 3 metres from opening.

c) Volume flow rate,  $\dot{V} = 9000$  l/s

d) Maximum required pressure loss,  $\Delta p = 40$  Pa.

e) Maximum required height,  $H = 1200$ mm.

- 1) From Table 1, a standard performance Type NL louvre would meet the required acoustic performance.
- 2) From Table 2, the maximum permissible face velocity, for  $\Delta p = 40$ Pa, is 2.4 m/s.
- 3) From Table 2, the maximum permissible face velocity,  $v_f$  for for an SNI of 45 minus 5 at 3m, is 3.7 m/s.
- 4) Size the louvre at the limiting velocity of 2.4 m/s.

$$\begin{aligned} \text{Required louvre area, } m^2 &= \dot{V} \div (v_f \times 1000) \\ &= 9000 \div (2.4 \times 1000) \\ &= 3.75 \end{aligned}$$

$$\begin{aligned} \text{Width, } B \text{ required} &= 3.75 \div H \text{ (in metres)} \\ &= 3.75 \div 1.2 \\ &= 3.125 \text{ metres} = 3125\text{mm} \end{aligned}$$

### Louvre Selection :

Type NL; B x H x, 3125 x 1200. (Specify material and finish – see page 10).

# Acoustic Performance

## Acoustic Performance

Acoustic louvre performance was derived from tests based upon DIN EN ISO 140-3. The test was carried out TROX acoustic test complex equipped with a reverberant room. Measurements with and without the test piece were compared to produce the 'Sound Reduction Index' (also known as 'Transmission Loss') of both the 'standard' performance NL acoustic louvre and the 'high' performance version NLH.

**Table 1 : Sound Reduction Index, SRI in dB**

Louvre Type	Octave centre frequency $f_m$ in Hz					
	125	250	500	1k	2k	4k
NL	1.4	6.2	9.9	13.0	16.3	14.2
NLH	3.0	11.8	18.7	26.6	29.9	26.8



# Pressure Loss · Regenerated Noise

## Aerodynamic Performance

The aerodynamic profile of the acoustic louvre blade ensures low pressure loss similar to conventional non-acoustic weather louvres of higher free area. The percentage free area varies with louvre height, with the smaller louvres most affected by the restriction of the top and bottom dummy sections.

Table 2

Type NL (ducted from atmosphere)

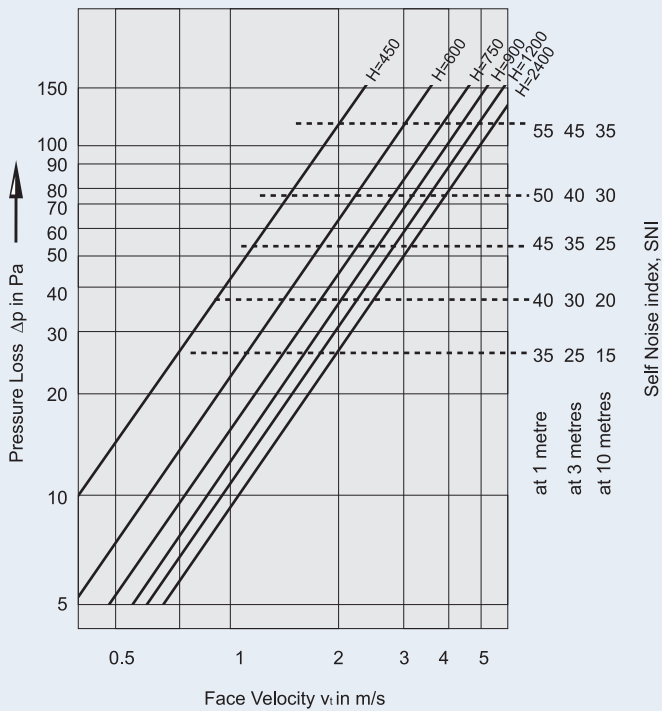

Type NLH (ducted from atmosphere)

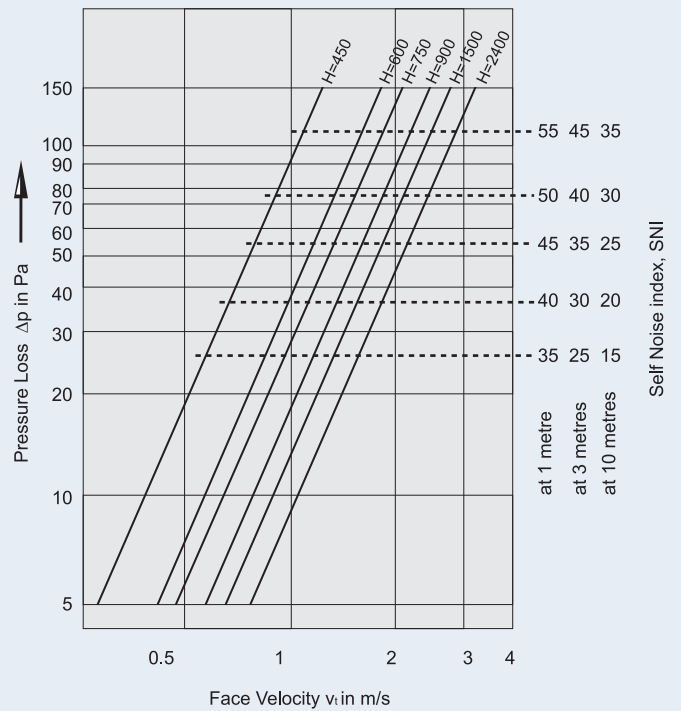

# Order Details



## Order Code

These codes do not need to be completed for standard products

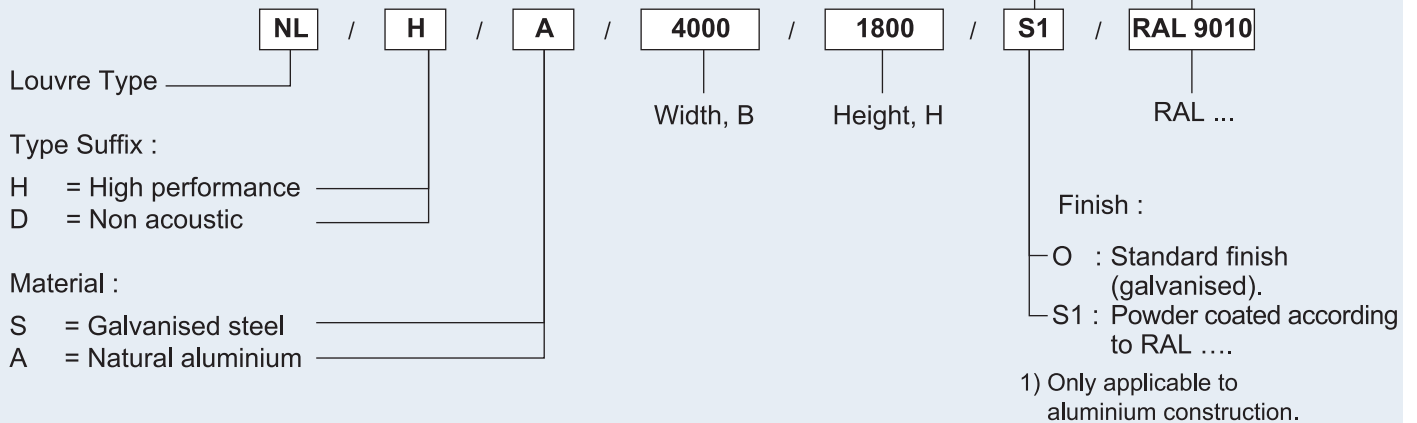

## Specification Text

Type NL acoustic louvre constructed from either galvanised sheet or natural mill aluminium with finish as specified. 1.5mm thick channel casing incorporates aerodynamic acoustic blades containing erosion protected Class O infill covered by perforated sheet metal. Casing sides are pre-slotted for fixing into a prepared opening.

## Order Example

Make : TROX  
 Type : NL/H/A/4000 x 1800 S1/RAL9010