

To the edge smaller holes, optional



Adjustable twin nozzles



Water connections



Eurovent certification



Tested to VDI 6022

Units for suspended ceilings

Type DID642



Super flat active chilled beam with two-way air discharge and horizontal heat exchanger, suitable for grid ceilings with grid size 600 or 625

Active chilled beam for heating and cooling, with 2-pipe or 4-pipe heat exchanger, for integration with various ceiling systems

- Preferably for room heights up to 4.0 m
- High heating and cooling capacity with a low conditioned primary air volume flow rate and low sound power level
- Five nozzle variants to optimise induction based on demand, including adjustable twin nozzles, i.e. one pair of nozzles with different diameters
- Hinged, removable induced air grille in two designs

Optional equipment and accessories

- Control system
- Additional casing for extract air or additional supply air
- Supply air and extract air units upon request
- Heat exchanger powder-coated black
- Powder coating in many different colours, e.g. RAL CLASSIC
- Adjustable air control blades for air direction control

Type		Page
DID642	General information	DID642 – 2
	Function	DID642 – 4
	Technical data	DID642 – 6
	Quick sizing	DID642 – 7
	Specification text	DID642 – 10
	Order code	DID642 – 11
	Attachments	DID642 – 13
	Dimensions and weight	DID642 – 14
	Installation examples	DID642 – 18
	Installation details	DID642 – 19
	Basic information and nomenclature	DID642 – 20

Application

Application

- Active chilled beams of Type DID642 for the integration into various ceiling systems, preferably for room heights up to 4.0 m
- Particularly suitable for grid ceilings with grid size 600 or 625
- Adjustable air control blades (optional) allow for the manual adjustment of the air discharge direction
- 2-pipe or 4-pipe heat exchangers enable good comfort levels with a low conditioned primary air volume flow rate
- Energy-efficient solution since water is used for heating and cooling

Special characteristics

- Adjustable air control blades for air direction control
- Hinged, removable induced air grille in two designs
- Horizontal heat exchanger as 2-pipe or 4-pipe system
- Internal nozzle plate with punched nozzles (non-combustible)
- Water connections at the narrow side, Ø12 mm Cu pipe, either with plain tails or with external thread or union nut, G½", flat seal

Nominal sizes

- 900, 1200, 1500, 1800, 2100, 2400, 2700, 3000 mm (3000 mm nur ohne Zusatzgehäuse)

Description

Variants

- Induced air grille
- Perforated metal facing, decreasing apertures towards the edges
 - D1: Perforated metal facing

Heat exchanger

- 2: For 2-pipe systems
- 4: For 4-pipe systems

Nozzle variants

- HE: Small
- S1: Medium
- S2: Large
- HP: Extra large
- DA: Adjustable twin nozzles, all nozzles are open (factory setting)

- Variants DS (small opening) and DB (large opening) can be adjusted by the customer if the nozzle variant DA has been selected. How the DID642 behaves in terms of ventilation with these settings can be calculated with the Easy Product Finder design program. DS and DB are not an order option.

Construction

- Powder-coated RAL 9010, pure white, gloss level 50 %
- P1: Powder-coated in additional RAL CLASSIC colours, gloss level 70 %
- P1: Powder-coated RAL 9006, white aluminium, gloss level 30 %

Attachments

- Additional casing for extract air or additional supply air
- Water connection A1: G½" external thread and flat seal
- Water connection A2: G½" union nut and flat seal
- Adjustable air control blades

Accessories

Control components

- KV: Cooling valve with actuator
 - HV: Heating valve with actuator
- Each valve with kVS value 0.25, 0.40, 0.63 or 1.00

Water connection

- R: Lockshield (2-pipe system: 1; 4-pipe system: 2), kVS value 1.32

Useful additions

- Connecting hoses
- Control equipment consisting of a control panel including a controller with integral room temperature sensor; valves and valve actuators; and lockshields
- X-AIRCONTROL control system

Construction features

- Spigot is suitable for circular ducts to EN 1506 or EN 13180
- 4 suspension points for on-site installation (by others)
- Five nozzle variants to optimise induction based on demand, including adjustable twin nozzles, i.e. one pair of nozzles with different diameters
- Induced air grille: Perforated sheet metal with circular holes, with or without decreasing apertures towards the edges
- Additional primary air spigot, optional
- Additional optional casing for supply or extract air

Materials and surfaces

- Casing, induced air grille, casing panels on the narrow sides, spigots and fixing brackets made of galvanised sheet steel
- Heat exchanger with copper tubes and aluminium fins
- Exposed surfaces are powder-coated pure white (RAL 9010) or in any other RAL CLASSIC colour
- Heat exchanger also in black (RAL 9005)
- Nozzle plate made of sheet steel
- Control blades made of polypropylene, flame retardant (V0) to UL 94

Standards and guidelines

- Products are certified by Eurovent (no. 09.12.432) and listed on the Eurovent website
- Declaration of hygiene conformity to VDI 6022

Maintenance

- No moving parts, hence low maintenance
- The heat exchanger can be vacuumed with an industrial vacuum cleaner if necessary
- VDI 6022, Part 1, applies (hygiene requirements for ventilation and air conditioning systems)

Functional description

Active chilled beams provide centrally conditioned primary air (fresh air to the room and use heat exchangers for additional cooling and/or heating. The primary air is discharged through nozzles (in 5 variants) into the mixing chambers; as a result of this, secondary air is induced. Secondary air (room air) is induced via the induced air grille and passes through the horizontal heat exchanger, where it is heated or cooled. Primary and secondary air mix and are then supplied to the room horizontally through the supply air slots.

Schematic illustration of DID642

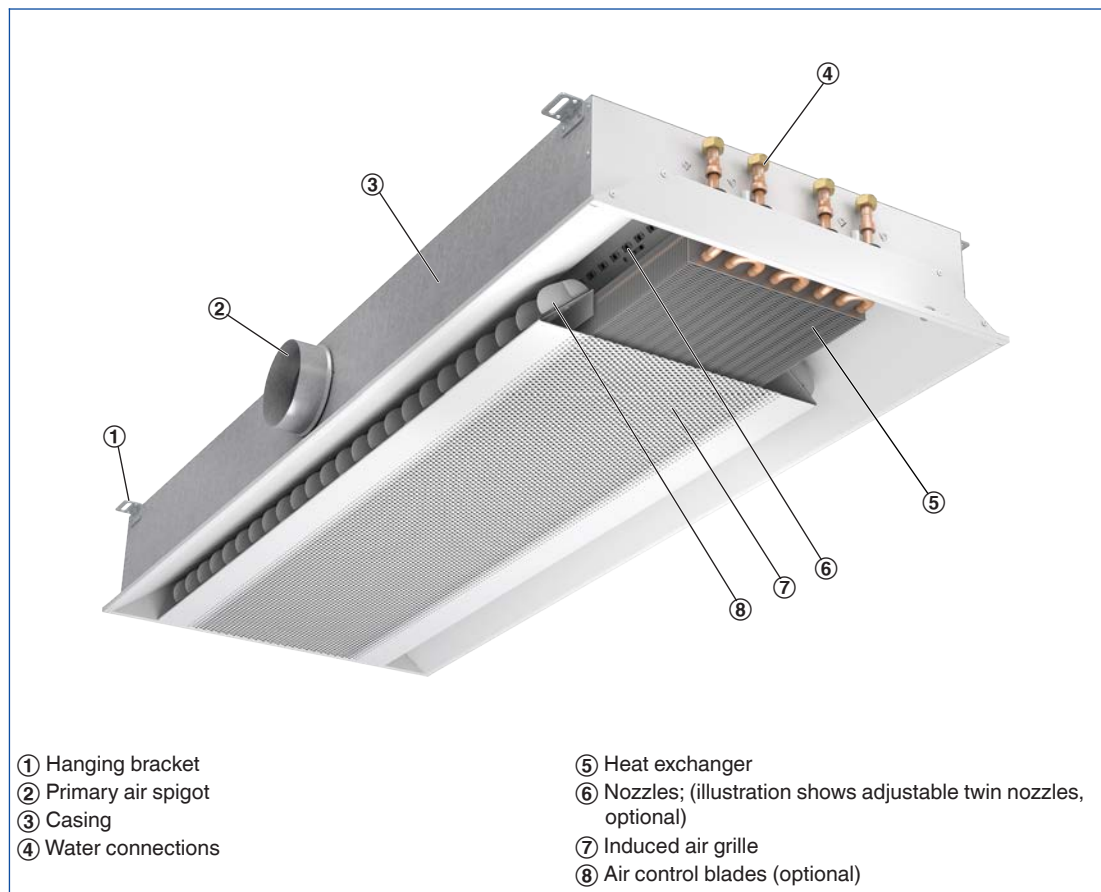

Principle of operation – DID642

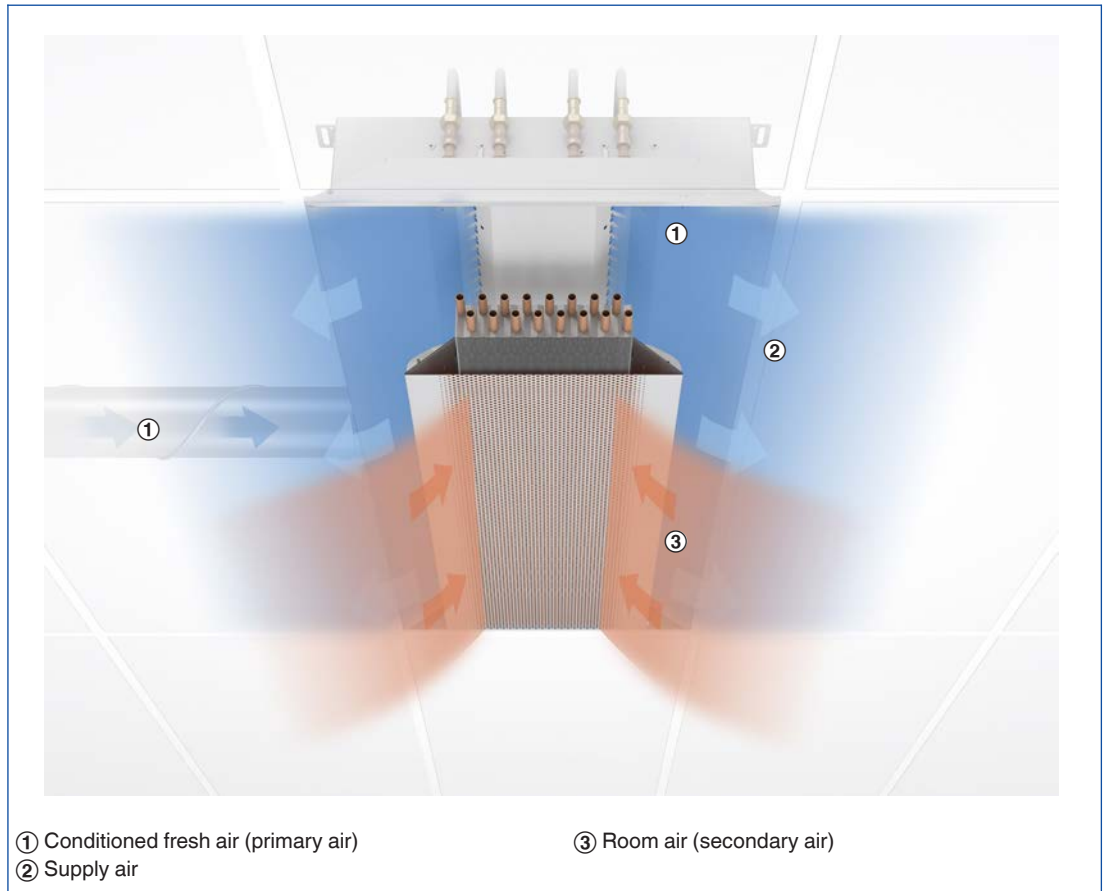

Nominal length	900, 1200, 1500, 1800, 2100, 2400, 2700, 3000 mm
Length	893 – 3000 mm
Height	170/205 mm
Width	593, 598, 618, 623 mm
Primary air spigot, diameter	123/158 mm
Primary air volume flow rate	10 – 125 l/s or 36 – 450 m ³ /h
Output, cooling	Up to 3100 W
Heating capacity	Up to 2330 W
Max. operating pressure, water side	6 bar
Max. operating temperature	75 °C

The quick sizing table contains operating points for defined reference units. In this quick sizing, a primary air connection with $D = 123 \text{ mm}$ is considered for the nozzles HE and S1. For nozzles S2, HP, DA, DB and DS, a primary air connection with $D = 158 \text{ mm}$ is considered.

Quick sizing

L_N	①	Primary air		② Δp_t	③ L_{WA}	Cooling operation				Heating operation		
		\dot{V}_{Pr}	\dot{V}_{Pr}			2- and 4-pipe system				4-pipe system		
		l/s	m ³ /h	Pa	dB(A)	\dot{Q}_{tot}	\dot{Q}_{WK}	Δt_w	Δp_w	$\dot{Q}_{WH} = \dot{Q}_{tot}$	Δt_w	Δp_w
						W	K	kPa	W	K	kPa	
900	HE	10	36	67	<15	545	424	1.2	9.9	688	3.9	0.9
		17	61	194	29	852	648	1.9	9.9	931	5.3	0.9
	S1	16	58	66	15	695	501	1.4	9.9	783	4.5	0.9
		28	100	197	32	1066	731	2.1	9.9	1034	5.9	0.9
	S2	17	61	31	<15	630	426	1.2	9.9	687	3.9	0.9
		43	155	200	38	1333	815	2.3	9.9	1094	6.3	0.9
	HP	26	93	34	<15	807	495	1.4	9.9	773	4.4	0.9
		62	223	197	42	1595	849	2.4	9.9	1151	6.6	0.9
	DS	10	36	65	<15	530	410	1.2	9.9	666	3.8	0.9
		17	62	193	30	845	638	1.8	9.9	920	5.3	0.9
DB	14	51	31	<15	551	381	1.1	9.9	644	3.7	0.9	
	35	126	192	36	1184	762	2.2	9.9	1059	6.1	0.9	
DA	21	75	34	<15	676	425	1.2	9.9	711	4.1	0.9	
	50	180	196	41	1389	787	2.3	9.9	1079	6.2	0.9	
1200	HE	14	50	71	<15	745	577	1.7	12.7	921	5.3	1.1
		23	83	195	30	1126	848	2.4	12.7	1215	7.0	1.1
	S1	22	79	67	19	929	664	1.9	12.7	1030	5.9	1.1
		38	136	200	36	1407	952	2.7	12.7	1342	7.7	1.1
	S2	23	83	31	<15	845	568	1.6	12.7	907	5.2	1.1
		58	200	200	42	1756	1053	3.0	12.7	1414	8.1	1.1
	HP	35	126	35	16	1076	654	1.9	12.7	1013	5.8	1.1
		84	302	199	44	2105	1095	3.1	12.7	1485	8.5	1.1
	DS	14	50	67	<15	726	559	1.6	12.7	893	5.1	1.1
		24	86	198	30	1133	845	2.4	12.7	1212	6.9	1.1
DB	20	72	34	<15	772	531	1.5	12.7	875	5.0	1.1	
	48	173	194	37	1574	995	2.9	12.7	1379	7.9	1.1	
DA	29	104	35	15	926	578	1.7	12.7	947	5.4	1.1	
	68	245	196	42	1841	1021	2.9	12.7	1398	8.0	1.1	
1500	HE	17	61	66	<15	895	691	2.0	15.5	1107	6.3	1.4
		29	105	197	31	1388	1036	3.0	15.5	1481	8.5	1.4
	S1	28	100	69	22	1154	819	2.3	15.5	1263	7.2	1.4
		47	170	199	38	1720	1151	3.3	15.5	1622	9.3	1.4
	S2	29	105	32	17	1055	704	2.0	15.5	1117	6.4	1.4
		72	260	195	45	2134	1263	3.6	15.5	1700	9.7	1.4
	HP	44	159	36	18	1337	805	2.3	15.5	1240	7.1	1.4
		99	356	178	45	2476	1285	3.7	15.5	1753	10.1	1.4
	DS	17	62	65	<15	887	679	1.9	15.5	1085	6.2	1.4
		30	108	197	31	1389	1028	2.9	15.5	1473	8.4	1.4
DB	25	90	34	<15	953	652	1.9	15.5	1070	6.1	1.4	
	61	220	200	38	1947	1211	3.5	15.5	1676	9.6	1.4	
DA	36	130	35	16	1143	708	2.0	15.5	1155	6.6	1.4	
	85	306	196	44	2255	1231	3.5	15.5	1124	9.7	1.4	

① Nozzle variant

② Pressure drop

③ Air-regenerated noise

Reference values

Parameter	Cooling	Heating
t_R	26 °C	22 °C
t_{Pr}	16 °C	22 °C
t_{WV}	16 °C	50 °C
$\dot{V}_W (L_N 900 - 1800 \text{ mm})$	300 l/h	150 l/h
$\dot{V}_W (L_N 2100 - 3000 \text{ mm})$	250 l/h	150 l/h

Quick sizing

L _N	①	Primary air		②	③	Cooling operation				Heating operation		
		\dot{V}_{Pr}	\dot{V}_{Pr}	Δp_t	L _{WA}	2- and 4-pipe system				4-pipe system		
		l/s	m ³ /h	Pa	dB(A)	\dot{Q}_{tot}	\dot{Q}_{WK}	Δt_w	Δp_w	$\dot{Q}_{WH} = \dot{Q}_{tot}$	Δt_w	Δp_w
						W		K	kPa	W	K	kPa
1800	HE	21	75	70	15	1083	832	2.4	18.2	1319	7.6	1.6
		35	125	194	32	1620	1202	3.4	18.2	1719	9.9	1.6
	S1	34	122	72	25	1381	973	2.8	18.2	1490	8.5	1.6
		56	200	194	40	1993	1323	3.8	18.2	1869	10.7	1.6
	S2	35	126	32	<15	1249	828	2.4	18.2	1310	7.5	1.6
		86	310	196	40	2497	1459	4.2	18.2	1968	11.3	1.6
	HP	54	194	37	22	1605	956	2.7	18.2		8.4	1.6
		106	382	145	44	2696	1417	4.1	18.2	1956	11.2	1.6
	DS	21	75	65	<15	1057	806	2.3	18.2	1281	7.3	1.6
		36	130	194	31	1635	1200	3.4	18.2	1718	9.8	1.6
	DB	30	108	33	<15	1129	768	2.2	18.2	1257	7.2	1.6
		73	263	197	39	2282	1402	4.0	18.2	1942	11.1	1.6
	DA	44	158	36	19	1371	842	2.4	18.2	1364	7.8	1.6
		100	360	189	45	2619	1414	4.1	18.2	1943	11.1	1.6
2100	HE	24	86	68	16	1189	901	3.1	15.2	1490	8.5	1.8
		41	147	198	33	1795	1303	4.5	15.2	1954	11.2	1.8
	S1	39	141	72	27	1527	1055	3.6	15.2	1687	9.7	1.8
		65	234	199	43	2205	1421	4.9	15.2	2116	12.1	1.8
	S2	41	148	33	<15	1411	916	3.2	15.2	1501	8.6	1.8
		100	360	196	42	2756	1551	5.3	15.2	2217	12.7	1.8
	HP	62	224	38	24	1787	1037	3.6	15.2	1658	9.5	1.8
		119	429	139	45	2925	1489	5.1	15.2	2179	12.5	1.8
	DS	25	90	67	<15	1211	910	3.1	15.2	1488	8.5	1.8
		43	155	200	32	1829	1310	4.5	15.2	1965	11.3	1.8
	DB	45	162	55	19	1670	1128	3.9	15.2	1764	10.1	1.8
		86	310	201	40	2621	1583	5.4	15.1	2324	13.3	1.8
	DA	66	238	61	29	1955	1158	4.0	15.1	1795	10.3	1.8
		106	382	158	44	2754	1476	5.1	15.1	2160	12.4	1.8
2400	HE	27	98	68	17	1333	1005	3.5	17.2	1663	9.5	2.1
		46	166	196	35	1989	1434	4.9	17.2	2161	12.4	2.1
	S1	45	162	75	30	1722	1180	4.1	17.2	1887	10.8	2.1
		73	263	199	44	2438	1558	5.4	17.2	2331	13.4	2.1
	S2	47	169	34	16	1589	1023	3.5	17.2	1678	9.6	2.1
		114	410	199	45	3078	1706	5.9	17.2	2452	14.1	2.1
	HP	72	260	40	28	2032	1166	4.0	17.2	1861	10.7	2.1
		121	436	114	45	3021	1562	5.4	17.2	2318	13.3	2.1
	DS	28	100	63	<15	1327	993	3.4	17.2	1636	9.4	2.1
		49	176	196	33	2035	1446	5.0	17.2	2177	12.5	2.1
	DB	40	144	33	<15	1431	949	3.3	17.2	1607	9.2	2.1
		97	350	198	42	2821	1650	5.7	17.2	2427	13.9	2.1
	DA	59	212	38	23	1750	1040	3.6	17.2	1744	10.0	2.1
		114	410	143	45	2929	1557	5.4	17.2	2306	13.2	2.1

① Nozzle variant

② Pressure drop

③ Air-regenerated noise

Reference values

Parameter	Cooling	Heating
t _R	26 °C	22 °C
t _{Pr}	16 °C	22 °C
t _{WV}	16 °C	50 °C
\dot{V}_W (L _N 900 – 1800 mm)	300 l/h	150 l/h
\dot{V}_W (L _N 2100 – 3000 mm)	250 l/h	150 l/h

Quick sizing

L _N	①	Primary air		②	③	Cooling operation				Heating operation		
		V̇ _{Pr} l/s	V̇ _{Pr} m ³ /h	Δp _t Pa	L _{WA} dB(A)	2- and 4-pipe system				4-pipe system		
						Q̇ _{tot} W	Q̇ _{wk} W	Δt _w K	Δp _w kPa	Q̇ _{WH} = Q̇ _{tot} W	Δt _w K	Δp _w kPa
2700	HE	31	112	72	19	1496	1121	3.9	19.2	1849	10.6	2.3
		52	187	200	36	2192	1566	5.4	19.2	2367	13.6	2.3
	S1	51	184	79	32	1919	1303	4.5	19.2	2083	11.9	2.3
		79	285	191	45	2621	1667	5.7	19.2	2512	14.4	2.3
	S2	53	191	35	19	1770	1131	3.9	19.2	1852	10.6	2.3
		117	421	170	45	3196	1787	6.1	19.2	2597	14.9	2.3
	HP	81	292	42	31	2258	1281	4.4	19.2	2047	11.7	2.3
		123	443	98	45	3106	1624	5.6	19.2	2442	14	2.3
	DS	32	115	67	16	1499	1114	3.8	19.2	1827	10.5	2.3
		55	198	197	33	2240	1578	5.4	19.2	2383	13.7	2.3
	DB	45	162	34	15	1588	1046	3.6	19.2	1771	10.2	2.3
		109	392	200	44	3101	1789	6.2	19.2	2644	15.2	2.3
	DA	66	238	39	26	1939	1143	3.9	19.2	1917	11	2.3
		118	425	126	45	3056	1633	5.6	19.2	2451	14.1	2.3
3000	HE	34	122	70	21	1608	1200	4.1	21.1	1989	11.4	2.6
		57	205	198	38	2364	1678	5.8	21.1	2548	14.6	2.6
	S1	56	202	81	34	2077	1401	4.8	21.1	2247	12.9	2.6
		88	316	197	47	2851	1794	6.2	21.1	2711	15.5	2.6
	S2	59	212	36	22	1938	1229	4.2	21.1	2015	11.6	2.6
		117	420	141	45	3244	1838	6.3	21.1	2705	15.5	2.6
	HP	90	324	45	35	2473	1388	4.8	21.1	2221	12.7	2.6
		125	450	86	45	3183	1677	5.8	21.1	2554	14.6	2.6
	DS	35	126	65	16	1620	1198	4.1	21.1	1972	11.3	2.6
		61	220	197	34	2438	1702	5.9	21.1	2578	14.8	2.6
	DB	50	180	35	17	1742	1140	3.9	21.1	1929	11.1	2.6
		117	421	190	45	3306	1897	6.5	21.1	2820	16.2	2.6
	DA	73	263	40	28	2117	1237	4.3	21.1	2079	11.9	2.6
		124	446	116	45	3207	1714	5.9	21.1	2597	14.9	2.6

① Nozzle variant

② Pressure drop

③ Air-regenerated noise

Reference values

Parameter	Cooling	Heating
t _R	26 °C	22 °C
t _{Pr}	16 °C	22 °C
t _{wv}	16 °C	50 °C
V̇ _w (L _N 900 – 1800 mm)	300 l/h	150 l/h
V̇ _w (L _N 2100 – 3000 mm)	250 l/h	150 l/h

Note

Information on units with additional casing for supply and extract air, and information on different conditions for sizing is available upon request.

This specification text describes the general properties of the product.

Description

Active chilled beams of Type DID642, with two-way air discharge and high thermal output, providing high thermal comfort levels.

For installation flush with the ceiling, preferably in rooms with a height up to 4.0 m.

The units consist of a casing with suspension points, a spigot, non-combustible nozzles, and a horizontal heat exchanger.

Five nozzle variants to optimise induction based on demand, including adjustable twin nozzles, i.e. one pair of nozzles with different diameters.

Special characteristics

- Adjustable air control blades for air direction control
- Hinged, removable induced air grille in two designs
- Horizontal heat exchanger as 2-pipe or 4-pipe system
- Internal nozzle plate with punched nozzles (non-combustible)
- Water connections at the narrow side, Ø12 mm Cu pipe, either with plain tails or with external thread or union nut, G½", flat seal

Materials and surfaces

- Casing, induced air grille, casing panels on the narrow sides, spigots and fixing brackets made of galvanised sheet steel
- Heat exchanger with copper tubes and aluminium fins
- Exposed surfaces are powder-coated pure white (RAL 9010) or in any other RAL CLASSIC colour
- Heat exchanger also in black (RAL 9005)
- Nozzle plate made of sheet steel
- Control blades made of polypropylene, flame retardant (V0) to UL 94

Construction

- Powder-coated RAL 9010, pure white, gloss level 50 %
- P1: Powder-coated in additional RAL CLASSIC colours, gloss level 70 %
- P1: Powder-coated RAL 9006, white aluminium, gloss level 30 %

Technical data

- Nominal length: 900, 1200, 1500, 1800, 2100, 2400, 2700, 3000 mm
- Length: 893 – 3000 mm
- Height: 170/205 mm
- Width: 593, 598, 618, 623 mm
- Primary air spigot, diameter: 123/158 mm
- Primary air volume flow rate: 10 – 125 l/s or 36 – 450 m³/h
- Cooling capacity: up to 3100 W
- Heating capacity: up to 2330 W
- Maximum operating pressure: 6 bar
- Maximum operating temperature: 75 °C

Sizing data

Primary air

- \dot{V} _____ [m³/h]
- Δp_t _____ [Pa]

Air-regenerated noise

- L_{WA} _____ [dB(A)]

Cooling

- \dot{Q}_{tot} _____ [W]

Heating

- \dot{Q}_{tot} _____ [W]

DID642

DID642 – D1 – 2 – HE – RR – AV – A1 / 1200 × 900 – 593 / 123 / 158 / P1 – RAL ... / LE / VS / KV – 0,63 / HV – 0,4 / R

1 2 3 4 5 6 7 8 9 10 11 12 13 14 15 16 17 18

1 Type

DID642 Active chilled beam

2 Induced air grille

No entry: Perforated metal facing, decreasing apertures towards the edges

D1 Perforated metal facing

3 Heat exchanger

2 2-pipe

4 4-pipe

4 Nozzle variant

HE Small

S1 Medium

S2 Large

HP Extra large

DA Adjustable twin nozzles, all nozzles are open (factory setting)

Sizing options: Adjustable twin nozzles, all nozzles are open (factory setting), adjustment during commissioning by others

DB and DS can be calculated with the EPF and adjusted by others The order variant for this is DA.

5 Arrangement of casings and connections

LL Casing on left, water connections on left

LR Casing on left, water connections on right

RL Casing on right, water connections on left

RR Casing on right, water connections on right

6 Additional casing – function and arrangement

No entry: none

Constructions LL, RR, are only available from $L = L_N + 250$ mm

AV Extract air, spigot at the front

AH Extract air, spigot at the rear

ZV Supply air, spigot at the front

ZH Supply air, spigot at the rear

7 Water connections

No entry required: pipe with plain tails $\varnothing 12$ mm

A1 With $G\frac{1}{2}$ " external thread and flat seal

A2 With $G\frac{1}{2}$ " union nut and flat seal

8 Unit size [mm]

$L \times L_N - B$

Total length (diffuser face) \times nominal size – width of front frame

L is up to 7 mm shorter than L_N

9 Primary air spigot, diameter

123

158

2x123

2x158

10 Additional casing – spigot diameter

Only for AV, AH, ZV, ZH

123

158

11 Exposed surface

No entry: powder-coated RAL 9010, pure white

P1 Powder-coated, specify RAL CLASSIC colour

Gloss level

RAL 9010 50 %

RAL 9006 30 %

all other RAL colours 70%

12 Air control blades

No entry: none

LE With air control blades

13 Valves and actuators

No entry: no control components

VS With control components (supplied separately)

14 Cooling valve

No entry: none

KV Cooling valve with actuator

15 kVS value – cooling valve

0.25

0.40

0.63

1.00

16 Heating valve

No entry: none

HV Heating valve with actuator

17 kVS value – heating valve

0.25

0.40

0.63

1.00

18 Lockshield

No entry: none

R With lockshield(s)

Order examples

Order example: DID642-2-S1-LL/1193x1200x593/123

Induced air grille	Perforated sheet metal with decreasing apertures towards the edges, staggered pitch
Heat exchanger	2-pipe system
Nozzle variant	Medium
Arrangement of casings and connections	Casing on left, water connections on left
Total length (diffuser face) × nominal length × width of front frame	1193 × 1200 × 593 mm
Primary air spigot – diameter	123 mm
Exposed surface	RAL 9010

Order example: DID642-D1-4-S2-RR-AV-A1/1798x1200x598/158/123/P1-RAL9006/LE/VS/
KV-0,40/HV-0,25/R

Induced air grille	Perforated sheet metal, staggered pitch
Heat exchanger	For 4-pipe systems
Nozzle variant	Large
Arrangement of casings and connections	Casing on right - water connections on right
Additional casing – function and arrangement	Extract air, spigot at the front
Water connections	With G½" external thread and flat seal
Total length (diffuser face) × nominal length × width of front frame	1798 × 1200 × 598 mm
Primary air spigot – diameter	158 mm
Additional casing – spigot diameter	123 mm
Exposed surface	RAL 9006
Air control elements	With
Valves and actuators	With
Cooling valve	With
kVS value – cooling valve	0.40
Heating valve	With
kVS value – heating valve	0.25
Lockshield	With

Air control element

If a high cooling capacity is required in a very small space with active chilled beams, optional air control blades allow for adjusting the air discharge pattern so that the acceptable air velocity in the occupied zone is not exceeded. The airflow of each active chilled beam is spread and discharged according to the room geometry. If the use of a room changes, the air discharge pattern can be optimised by adjusting the air control blades accordingly.

- It is possible to adjust several air control blades (i.e. a set of air control blades) together
- For fine adjustment, the sets of air control blades can be disconnected from complementary to one another

- To adjust a set of air control blades, use both hands to move the two outer blades of the set as required
- Maximum possible adjustment is 45° to the right or left in steps of 15°
- The blades are factory set to straight air discharge

If the air discharge is not straight, the water-side capacity will be slightly affected. Air control blades have to be factory fitted; it is not possible to retrofit air control blades at a later stage.

Air control element

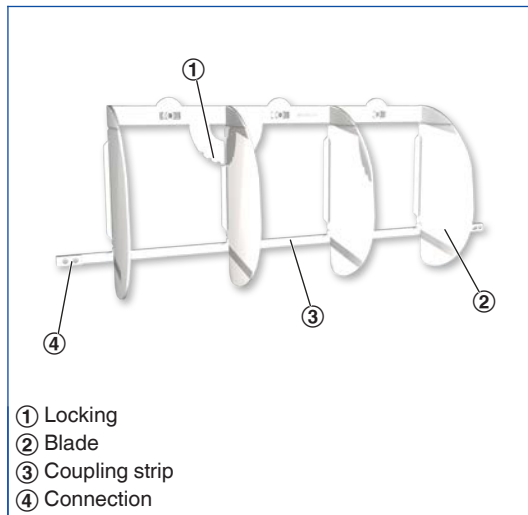

Straight air discharge

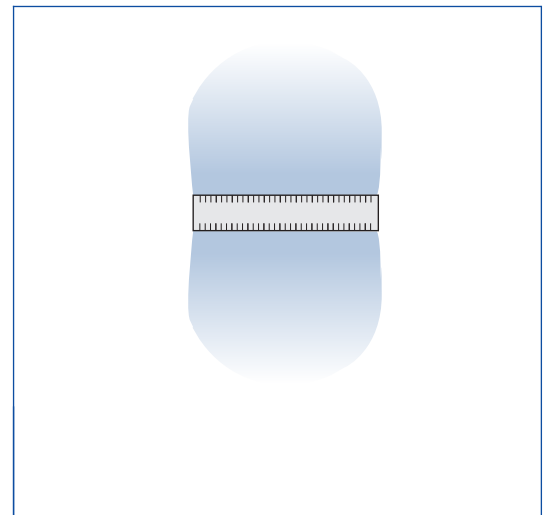

Angled air discharge

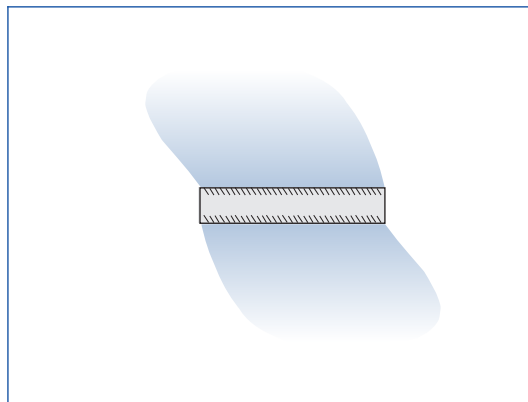

Divergent air discharge

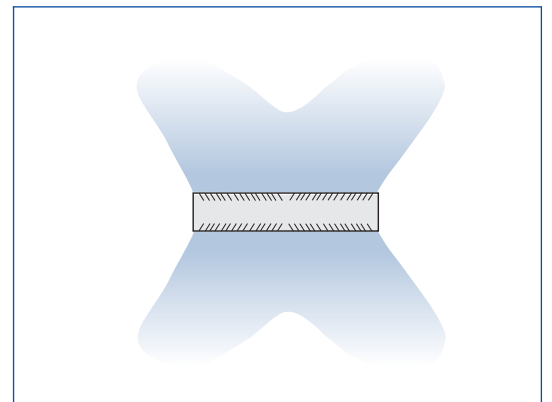

Available combinations of spigots and nozzles

H	H	170 mm		205 mm	
Spigot	Spigot	1 x 125	2 x 125	1 x 160	2 x 160
Nozzle	HE	■	□		
	S1	■	□	□	
	S2		□	■	□
	HP		□	■	□
	DA		□	■	□

- Standard variant
- Selectable as an option not used

- $L_1 = L_N - 62$
- $L_2 = (L_N - 62) / 2$
- $L_3 = L - L_N + 10$
- $L_4 = L - L_N + 52$

Dimensions [mm]

ØD	H	HS
123	170	99
158	205	116.5

Water connections

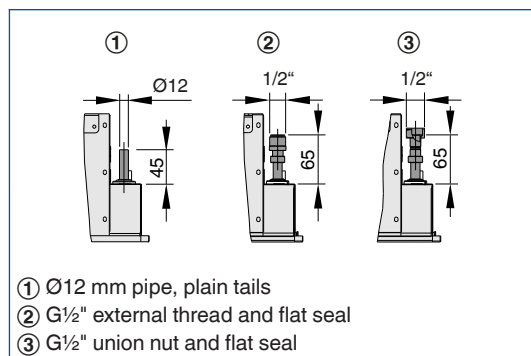

Weights

L_N	L_{min}	L_{max}	m	①
	mm			
900	893	1500	20 - 33	1.8
1200	1193	1800	26 - 40	2.4
1500	1493	2100	33 - 46	3.0
1800	1793	2400	39 - 53	3.6
2100	2093	2700	46 - 59	4.2
2400	2393	3000	53 - 66	4.8
2700	2693	3000	59 - 66	5.4
3000	2993	3000	66	6.0

L = Total length (diffuser face)

L_N = Nominal length

① Contained water

Non-active section as extension: 10 kg/m

Differences in weight for the various widths can be neglected

Casing arrangement
Supply air

DID642-...-RR

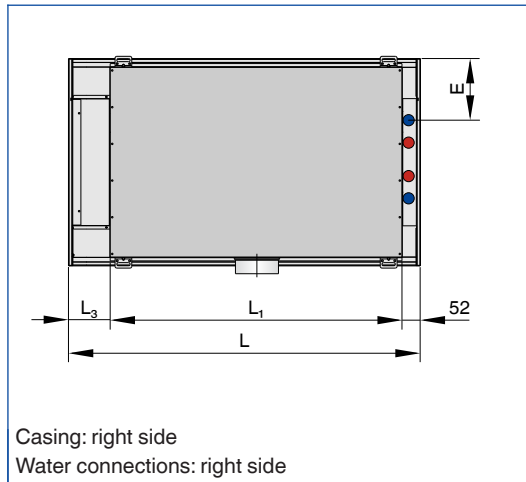

Variant RR only from $L = L_N + 200$ mm

DID642-...-RL

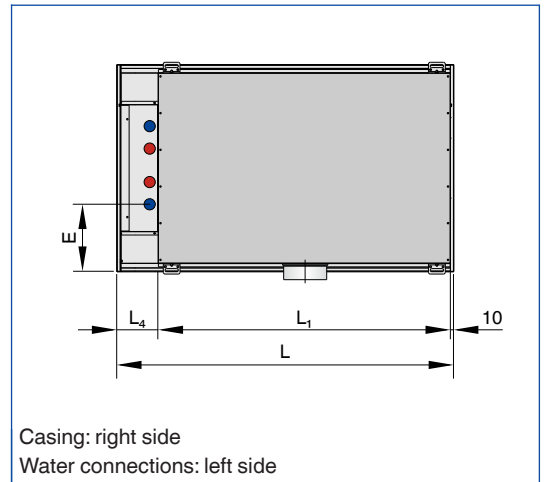

DID642-...-LR

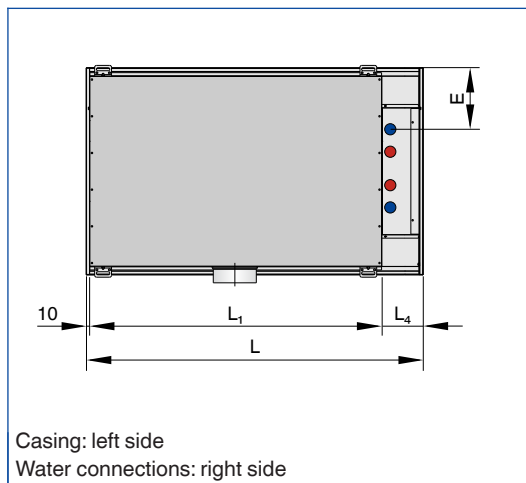

DID642-...-LL

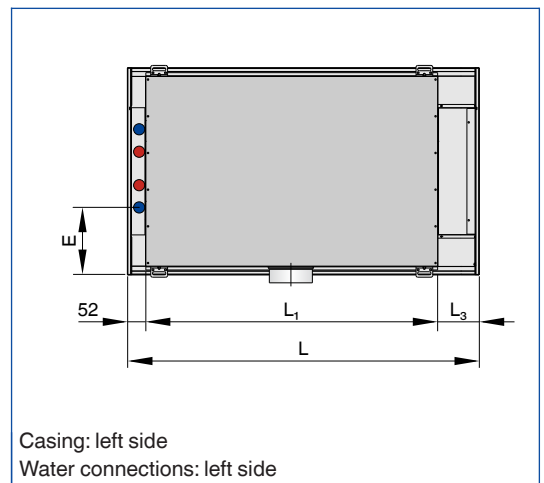

Variant LL only from $L = L_N + 200$ mm

- $L_1 = L_N - 62$
- $L_2 = (L_N - 62)/2$
- $L_3 = L - L_N + 10$
- $L_4 = L - L_N + 52$

Dimensions [mm]

B	E
593	193
598	195
618	205
623	208

B = Width of front frame

- $L_5 = L - 62$
- $L_6 = (L_N - 74)/2$
- $L_7 = (L_N - 64)/2$
- $L_8 = (L_N - 60)/4$
- $L_9 = (L - L_N + 53)/2 - 26$

Dimensions [mm]

ØD	ØD ₁	H	HS
123	123	170	99
	158	205	116.5
158	123	205	116.5
	158	205	116.5

Water connections

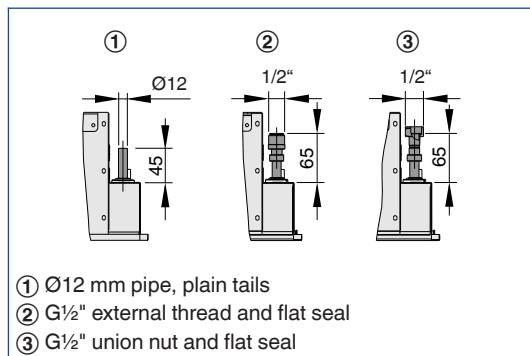

Weights

L _N	ØD ₁ [mm]		L _{max}	m	①
	123	158			
	L _{min}		kg		
900	1150	1185	1500	20 - 33	1.8
1200	1450	1485	1800	26 - 40	2.4
1500	1750	1785	2100	33 - 46	3.0
1800	2050	2085	2400	39 - 53	3.6
2100	2350	2385	2700	46 - 59	4.2
2400	2650	2685	3000	53 - 66	4.8
2700	2950	2985	3000	59 - 66	5.4

L = Total length (diffuser face)

L_N = Nominal length

① Contained water

Non-active section as extension: 10 kg/m

Differences in weight for the various widths can be neglected

**Casing arrangement
With additional casing**

DID642-...-RR-AV, DID642-...-RR-ZV

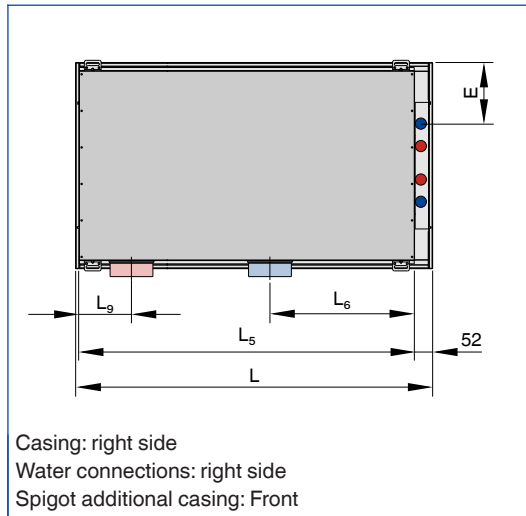

Variant RR-AV, RR-ZV only from $L = L_N + 250$ mm

DID642-...-LL-AV, DID642-...-LL-ZV

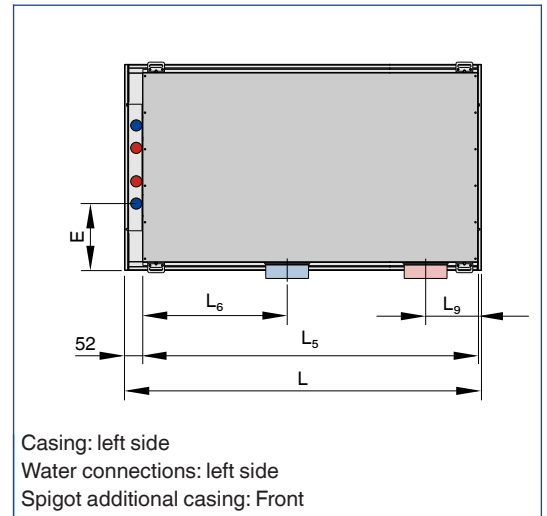

Variant LL-AV, LL-ZV only from $L = L_N + 250$ mm

DID642-...-RR-AH, DID642-...-RR-ZH

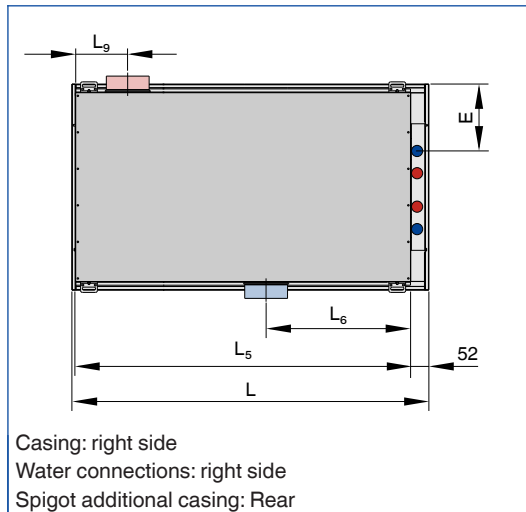

Variant RR-AH, RR-ZH only from $L = L_N + 250$ mm

DID642-...-LL-AH, DID642-...-LL-ZH

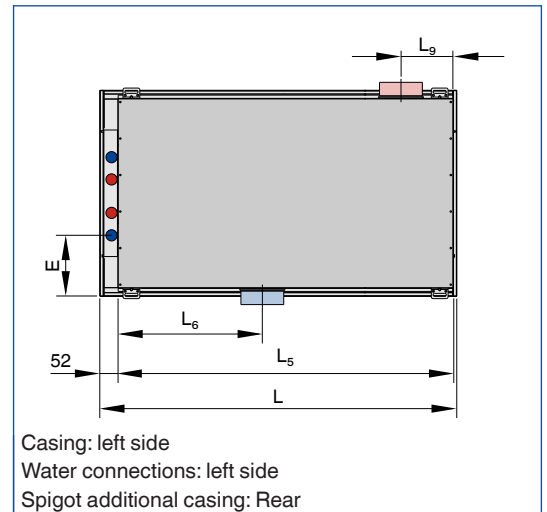

Variant LL-AH, LL-ZH only from $L = L_N + 250$ mm

- $L_5 = L - 62$
- $L_6 = (L_N - 74) / 2$
- $L_7 = (L_N - 64) / 2$
- $L_8 = (L_N - 60) / 4$
- $L_9 = (L - L_N + 53) / 2 - 26$

Dimensions [mm]

B	E
593	193
598	195
618	205
623	208

B = Width of front frame

Installation into grid ceilings



Installation in T-bar ceilings



Installation in continuous ceilings



Installation and commissioning

- Preferably for clear room heights up to 4.0 m
- Flush ceiling installation
- Side entry primary air spigot
- Lengths from 893 to 3000 mm, and widths of 593, 598, 618 and 623 mm, hence suitable for all ceiling systems, particularly for grid ceilings with grid size 600 or 625
- Installation and connections to be performed by others; fixing, connection and sealing material to be provided by others
- Active chilled beam has 4 suspension points for on-site installation (by others)
- Heat exchangers are fitted with water flow and water return connections at the narrow side

Installation into T-bar ceilings or continuous ceilings

- To avoid too much load on the ceiling, the suspension points should be used

Ceiling installation, visible T-bars

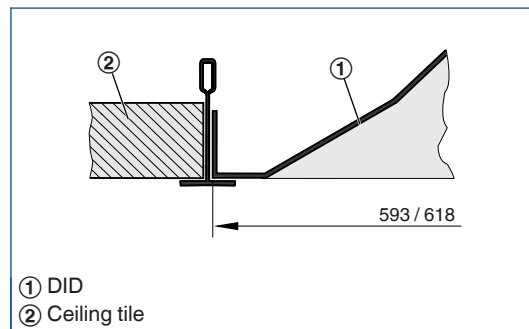

Ceiling installation, concealed T-bars

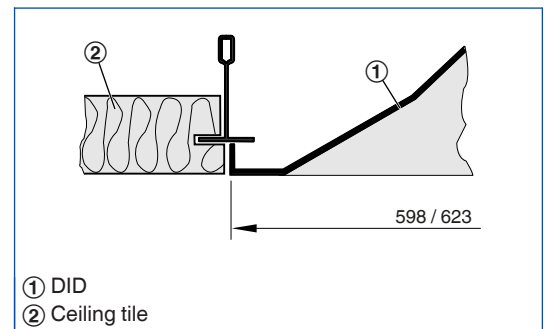

Ceiling installation with clamping profile

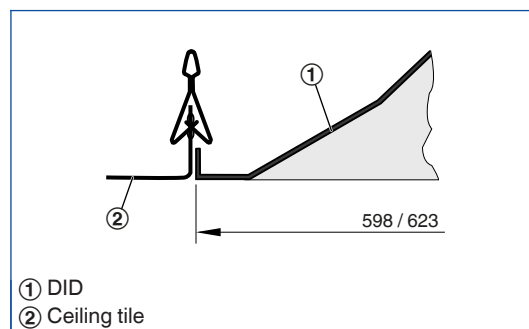

Ceiling installation, plasterboard

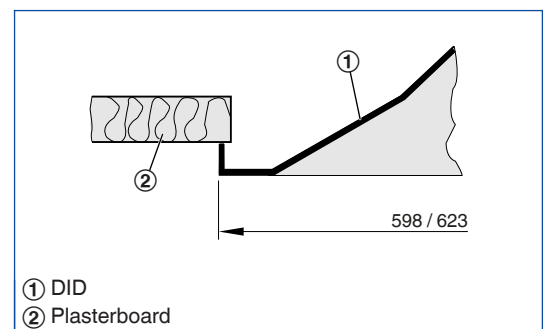

Nomenclature

L_{WA} [dB(A)]

Sound power level

t_{Pr} [°C]

Primary air temperature

t_{WV} [C°]

Water flow temperature – cooling/heating

t_R [C°]

Room temperature

t_{AN} [C°]

Secondary air intake temperature

Q_{Pr} [W]

Thermal output – primary air

Q_{tot} [W]

Thermal output – total

Q_W [W]

Thermal output – water side, cooling/heating

\dot{V}_{Pr} [l/s/m³/h]

Primary air volume flow rate

\dot{V}_W [l/h]

Water flow rate – cooling/heating

\dot{V} [l/h]

Volume flow rate

Δt_W [K]

Temperature difference – water

Δp_W [kPa]

Water side pressure drop

Δp_t [Pa]

Total pressure drop, air side

$\Delta t_{Pr} = t_{Pr} - t_R$ [K]

Difference between primary air temperature and room temperature

$\Delta t_{RWV} = t_{WV} - t_R$ [K]

Difference between water flow temperature and room temperature

Δt_{Wm-Ref} [K]

Difference between mean water temperature and reference temperature

Principal dimensions

L_N [mm]

Nominal length

Mixed flow

The supply air is discharged from the air terminal device into the space with a velocity between 2 and 5 m/s. The resulting air jet mixes with the room air, ventilating the entire space. The mixed flow air distribution typically provides a uniform temperature distribution and air quality within the space. The originally high velocity of the turbulent air jets decreases rapidly due to the high induction levels of mixed flow air distribution systems.

Schematic illustration of mixed flow ventilation

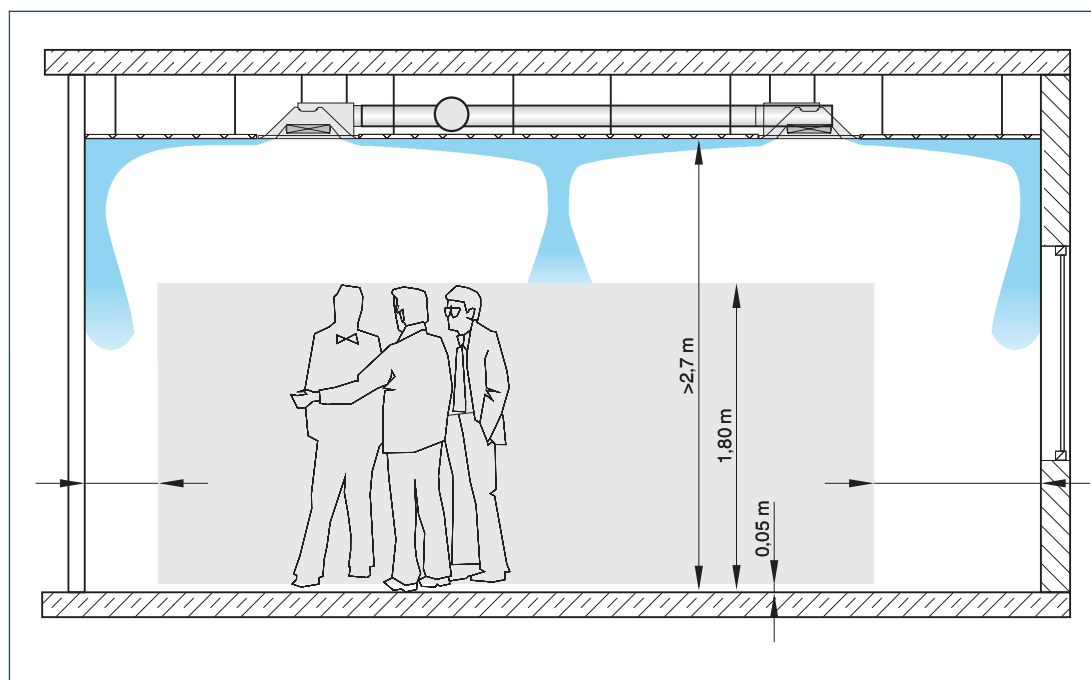

Heat exchanger

The maximum water-side operating pressure for all heat exchangers is 6 bar.
The maximum water flow temperature (heating circuit) for all heat exchangers is 75 °C; if flexible hoses are used, the water flow temperature should not exceed 55 °C. Units for other pressures and temperatures are available on request.

The water flow temperature (cooling circuit) should be at least 16 °C such that it does not permanently fall below the dew point. For units with a condensate drip tray, the water flow temperature may be reduced to 15 °C.

Heat exchanger as 2-pipe system

Air-water systems with a 2-pipe heat exchanger may be used for either heating or cooling.

In changeover mode, it is possible to use all units within a water circuit exclusively for cooling in summer and exclusively for heating in winter.

Heat exchanger as 2-pipe system



Heat exchanger as 4-pipe system

Air-water systems with a 4-pipe heat exchanger may be used for both heating and cooling.

Depending on the season, i.e. especially in spring and autumn, it may be possible that an office has to be heated in the morning and cooled in the afternoon.

Heat exchanger as 4-pipe system

