



# AHU

## X-CUBE compact

including X-CUBE compact accessories



# TROX® TECHNIK

The art of handling air

TROX GmbH  
Heinrich-Trox-Platz  
47504 Neukirchen-Vluyn, Germany  
Germany  
Telephone: +49 2845 202-0  
Fax: +49 2845 202-265  
E-mail: trox-de@troxgroup.com  
Internet: www.trox.de

A00000052573, 6, GB/en  
03/2021

© TROX GmbH 2015

### About this manual

This transport and installation manual enables operating or service personnel to use the X-CUBE compact air handling unit (AHU) safely and efficiently.

The transport and installation manual must be kept near the unit to be available for use at all times.

This transport and installation manual is intended for use by fitting and installation companies, operators, in-house technicians, technical staff or instructed persons, and skilled qualified electricians or air conditioning technicians.

It is essential that these individuals read and fully understand this transport and installation manual before starting any work. The basic prerequisite for safe working is to comply with the safety notes and all instructions in this manual.

The local regulations for health and safety at work and the general safety regulations for the area of application of the air handling unit also apply.

Illustrations in this transport and installation manual are mainly for information and may differ from the actual design of the air handling unit.

### Copyright

This document, including all illustrations, is protected by copyright and pertains only to the corresponding unit.

Any use without our consent may be an infringement of copyright, and the violator will be held liable for any damage.

This applies in particular to:

- Publishing content
- Copying content
- Translating content
- Microcopying content
- Saving content to electronic systems and editing it

### TROX Technical Service

To ensure that your request is processed as quickly as possible, please keep the following information ready:

- Product name
- TROX order number
- Delivery date
- Brief description of the fault

Online	<a href="http://www.troxtechnik.com">www.troxtechnik.com</a>
Phone	+49 2845 202-400

### Limitation of liability

The information in this manual has been compiled with reference to the applicable standards and guidelines, the state of the art, and our expertise and experience of many years.

The manufacturer does not accept any liability for damages resulting from:

- Non-compliance with this manual
- Incorrect use
- Operation or handling by untrained individuals
- Unauthorised modifications
- Technical changes
- Use of non-approved replacement parts

The actual scope of delivery may differ from the information in this manual for bespoke constructions, additional order options or as a result of recent technical changes.

The obligations agreed in the order, the general terms and conditions, the manufacturer's terms of delivery, and the legal regulations in effect at the time the contract is signed shall apply.

We reserve the right to make technical changes.

### Warranty claims

The provisions of the respective delivery terms apply to warranty claims. For purchase orders placed with TROX GmbH, these are the regulations in section "VI. Warranty claims" of the Delivery and Payment Terms of TROX GmbH, see [www.trox.de/en/](http://www.trox.de/en/).

### Other applicable documentation

In addition to these instructions, the following documents apply:

- Order confirmation
- Air handling unit data sheet from TROX GmbH
- Product drawings
- Data sheets for components from other suppliers, if any
- Circuit diagram for the air handling unit
- Additional drawings, if any
- X-CUBE compact operating manual
- Installation and commissioning manual for X-CUBE compact accessories

## Safety notes

Symbols are used in this manual to alert readers to areas of potential hazard. Signal words express the degree of the hazard.

Comply with all safety instructions and proceed carefully to avoid accidents, injuries and damage to property.

### **DANGER!**

Imminently hazardous situation which, if not avoided, will result in death or serious injury.

### **WARNING!**

Potentially hazardous situation which, if not avoided, may result in death or serious injury.

### **CAUTION!**

Potentially hazardous situation which, if not avoided, may result in minor or moderate injury.

### **NOTICE!**

Potentially hazardous situation which, if not avoided, may result in property damage.

### **ENVIRONMENT!**

Environmental pollution hazard.

## Tips and recommendations



*Useful tips and recommendations as well as information for efficient and fault-free operation.*

## Safety notes as part of instructions

Safety notes may refer to individual instructions. In this case, safety notes will be included in the instructions and hence facilitate following the instructions. The above listed signal words will be used.

Example:

1. ▶ Loosen the screw.

2. ▶

### **CAUTION!**



**Danger of finger entrapment when closing the lid.**







Be careful when closing the lid.

3. ▶ Tighten the screw.

## Specific safety notes

The following symbols are used in safety notes to alert you to specific hazards:

Warning signs	Type of danger
	Warning – hand injuries.
	Warning - danger of falling.
	Warning – danger zone.

<b>1</b>	<b>Overview</b> .....	<b>6</b>			
<b>2</b>	<b>Safety</b> .....	<b>8</b>			
	2.1 System owner's responsibility .....	8			
	2.2 Personnel requirements .....	8			
	2.3 Personal protective equipment .....	9			
<b>3</b>	<b>Transport and storage</b> .....	<b>10</b>			
	3.1 Delivery of the air handling unit .....	10			
	3.1.1 Complete and partial units .....	10			
	3.1.2 Symbols on the packaging .....	10			
	3.2 Delivery check .....	10			
	3.3 Moving packages .....	11			
	3.3.1 Safety notes regarding transport .....	11			
	3.3.2 Moving packages with a forklift or pallet truck .....	12			
	3.3.3 Moving packages with a crane .....	13			
	3.4 Storing packages .....	15			
	3.5 Unpacking .....	15			
<b>4</b>	<b>Setup and assembly</b> .....	<b>17</b>			
	4.1 Safety notes regarding setup and assembly .....	17			
	4.2 Requirements for the installation location .....	17			
	4.2.1 Requirements for indoor installation .....	17			
	4.2.2 Requirements for outdoor installation .....	18			
	4.3 Preventing vibration and structure-borne noise .....	19			
	4.4 Removal of AHU casing units .....	19			
	4.5 Setting up and assembling the air handling unit .....	20			
	4.5.1 Setting up the AHU or AHU casing units .....	20			
	4.5.2 Before assembly .....	21			
	4.5.3 Assembling AHU casing units .....	22			
	4.5.4 Installing accessories .....	24			
<b>5</b>	<b>Installation</b> .....	<b>27</b>			
	5.1 Safety notes regarding installation .....	27			
	5.2 Before installation .....	27			
	5.3 Connecting the condensate drain .....	28			
	5.4  Connecting the heating coil/cooling coil .....	30			
	5.5 Connecting the air handling unit to the power supply .....	31			
	5.6 Integrating the air handling unit with the central BMS .....	31			
	5.7 Connecting the air handling unit to your PC or local network .....	31			
<b>6</b>	<b>Initial commissioning</b> .....	<b>33</b>			
	6.1 Safety notes regarding initial commissioning .....	33			
	6.2 Before initial commissioning .....	33			
	6.3 Setting up and adjusting AHU casing units .....	34			
	6.3.1  Filter .....	34			
	6.3.2  Heating coil/cooling coil .....	34			
	6.3.3  Multileaf dampers .....	35			
	6.3.4  Rotary heat exchanger .....	36			
	6.3.5 Droplet eliminator .....	37			
	6.3.6  Plate heat exchanger .....	37			
	6.3.7 Setting up accessories .....	37			
	6.4 Starting the air handling unit .....	38			
	6.4.1 Before you start the AHU .....	38			
	6.4.2 Starting .....	38			
	6.5 Configuring the air handling unit .....	38			
	6.5.1 X-CUBE controller communication, setup .....	38			
	6.5.2 Setting up network communication .....	39			
	6.6 Logging in to the web server .....	41			
<b>7</b>	<b>Disassembly and disposal</b> .....	<b>42</b>			
	7.1 Safety notes regarding disassembly and disposal .....	42			
	7.2 Disassembly .....	43			
	7.3 Disposal .....	43			
<b>8</b>	<b>FAQ</b> .....	<b>44</b>			
<b>9</b>	<b>Index</b> .....	<b>46</b>			
	<b>Appendix</b> .....	<b>48</b>			
	A Adjusting the storage mass .....	49			
	B Drive equipment for rotary heat exchanger .....	55			
	C Circuit diagram, controls tray, 230 V AC-PWT .....	61			
	D Circuit diagram, controls tray, 230 V AC-RWT .....	75			
	E Circuit diagram, controls tray, 400 V AC-PWT .....	89			
	F Circuit diagram, controls tray, 400 V AC-RWT .....	103			
	G Accessories for X-CUBE compact .....	117			

# 1 Overview

## Unit with rotary heat exchanger

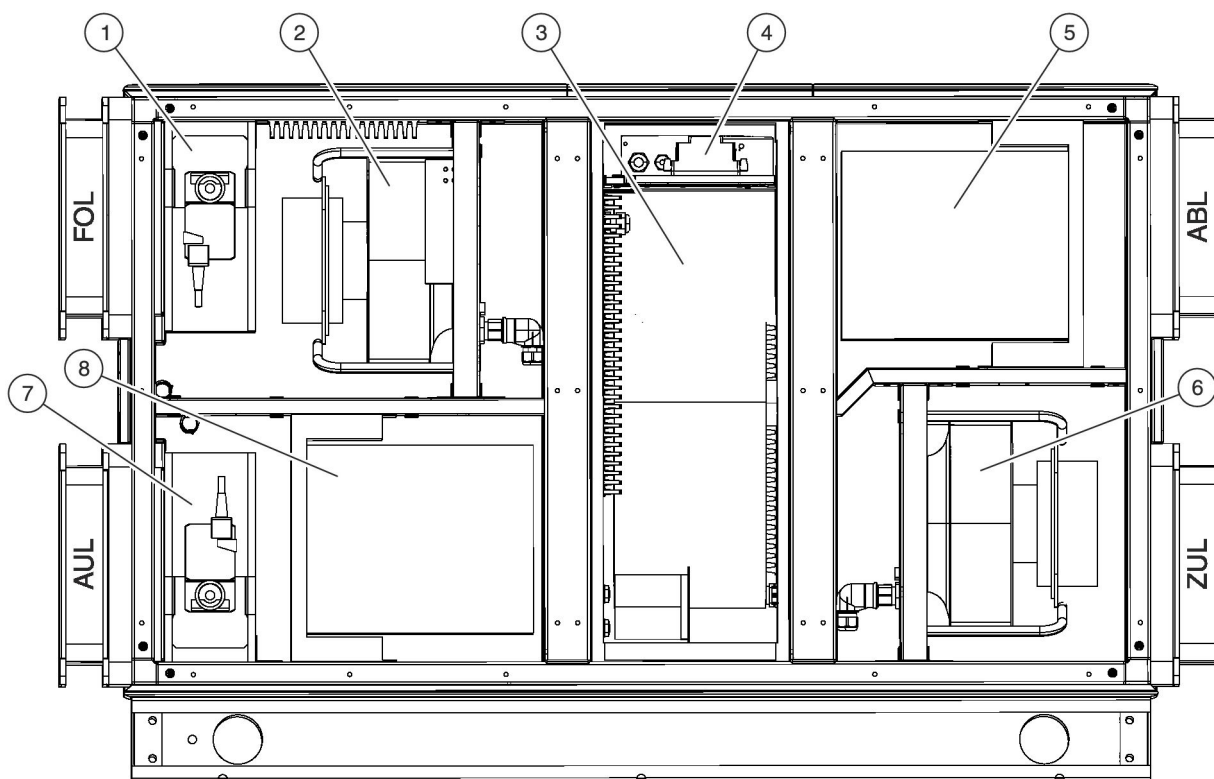

Fig. 1: Unit with rotary heat exchanger

- |   |                       |     |                   |
|---|-----------------------|-----|-------------------|
| 1 | Multileaf dampers     | 7   | Multileaf dampers |
| 2 | Centrifugal fan       | 8   | Filter            |
| 3 | Rotary heat exchanger | FOL | Exhaust air       |
| 4 | X-CUBE control        | ABL | Extract air       |
| 5 | Filter                | ZUL | Supply air        |
| 6 | Centrifugal fan       | AUL | Outdoor air       |

Unit with plate heat exchanger

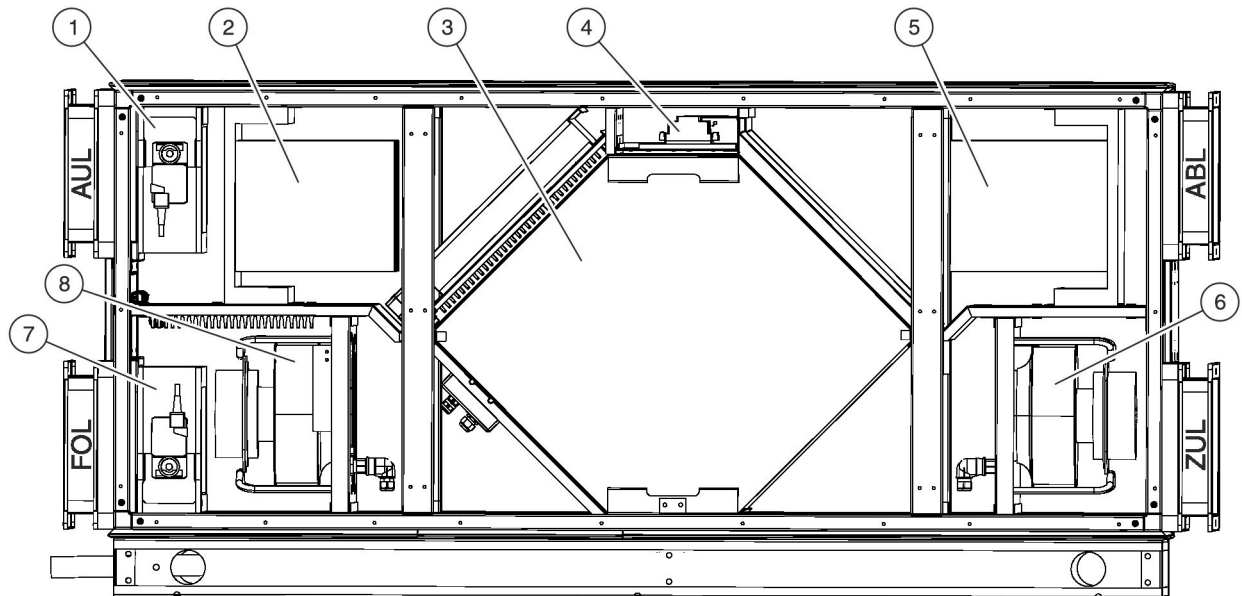

Fig. 2: Unit with plate heat exchanger

- |   |                      |     |                   |
|---|----------------------|-----|-------------------|
| 1 | Multileaf dampers    | 7   | Multileaf dampers |
| 2 | Filter               | 8   | Centrifugal fan   |
| 3 | Plate heat exchanger | AUL | Outdoor air       |
| 4 | X-CUBE control       | ABL | Extract air       |
| 5 | Filter               | ZUL | Supply air        |
| 6 | Centrifugal fan      | FOL | Exhaust air       |

The components actually used for a particular X-CUBE compact unit depend on the order specification. The following table ( ↗ Table on page 7 ) lists the components that can make up an X-CUBE compact unit.

Symbol	Meaning	Symbol	Meaning
	Heating coil		Multileaf dampers ( Fig. 1 /1+7) ( Fig. 2 /1+7)
	Cooling coil		Centrifugal fan ( Fig. 1 /2+6) ( Fig. 2 /6+8)
	Filter ( Fig. 1 /5+8) ( Fig. 2 /2+5)		Plate heat exchanger ( Fig. 2 /3)
	Rotary heat exchanger ( Fig. 1 /3)		Roof for outdoor installation
	X-CUBE control (controls) ( Fig. 1 /4) ( Fig. 2 /4)		

## 2 Safety

### 2.1 System owner's responsibility

#### System owner

The system owner is a natural or legal person who for commercial or business purposes owns or manages the air handling unit or allows third parties to use or operate it, but continues to bear legal responsibility for the safety of users, staff or third parties while the product is in use.

#### System owner's obligations

The unit is intended for commercial use. The system owner is therefore subject to the legal obligations of occupational health and safety regulations.

In addition to the safety notes in this manual, the applicable regulations for safety, accident prevention and environmental protection must also be complied with.

In particular:

- The system owner must establish on site a coherent fire protection strategy and include the air handling unit in this strategy.
- The system owner must establish on site a coherent lightning protection strategy and include the air handling unit in this strategy.
- The system owner must name responsible persons for transport, storage, assembly, installation, commissioning, transfer, disassembly and removal of the unit.
- The system owner must commission a skilled qualified electrician to create equipotential bonding.
- The system owner has to ensure that all individuals who handle or use the air handling unit have read and understood this manual.
- The system owner must provide the employees with the required personal protective equipment.
- The system owner must have all safeguards tested regularly to ensure that they are functional and complete.
- The system owner must ensure compliance with the national legal provisions.
- The system owner must have technical and hygiene tests carried out and documented before commissioning the air handling unit for the first time. The tests have to be repeated at regular intervals.

### 2.2 Personnel requirements

#### WARNING!

#### **Danger of injury or risk of damage to property due to insufficiently qualified individuals!**

Insufficiently qualified individuals are not aware of the risks involved in working with the air handling unit and are hence likely to put themselves or others into danger, causing severe or fatal injuries.

- Have any work carried out only by qualified personnel.
- Keep insufficiently qualified individuals away from the work area.

#### **Crane driver**

Crane drivers are physically and mentally able to operate a crane on their own.

Crane drivers are qualified to operate a crane and have proven the required skillset to the system owner.

Crane drivers are commissioned by the system owner. Crane drivers are commissioned in writing if the crane is a mobile crane.

Crane drivers have to be at least 18 years old.

#### **Forklift driver**

Forklift drivers are qualified to operate driver-operated forklift trucks; they are commissioned in writing by the system owner to operate such a truck.

Forklift drivers are responsible for moving pallets.

#### **HVAC technician**

HVAC technicians are individuals who have sufficient professional or technical training in the field they are working in to enable them to carry out their assigned duties at the level of responsibility allocated to them and in compliance with the relevant guidelines, safety regulations and instructions. HVAC technicians are individuals who have in-depth knowledge and skills related to HVAC systems; they are also responsible for the professional completion of the work under consideration.

HVAC technicians are individuals who have sufficient professional or technical training, knowledge and actual experience to enable them to work on HVAC systems, understand any potential hazards related to the work under consideration, and recognise and avoid any risks involved.

#### **Skilled qualified electrician**

Skilled qualified electricians are individuals who have sufficient professional or technical training, knowledge and actual experience to enable them to work on electrical systems, understand any potential hazards related to the work under consideration, and recognise and avoid any risks involved.



## 2.3 Personal protective equipment

### Hearing protection



Hearing protection protects against hearing damage resulting from noise exposure.

### Industrial safety helmet



Industrial safety helmets protect the head from falling objects, suspended loads, and the effects of striking the head against stationary objects.

### Protective clothing



Protective clothing is close-fitting, with low tear resistance, close-fitting sleeves, and no projecting parts.

### Protective gloves



Protective gloves protect hands from friction, abrasions, punctures, deep cuts, and direct contact with hot surfaces.

### Safety harness



The safety harness protects personnel from falling when there is an increased risk of falling. The risk of falling is increased when certain height differences are exceeded and the workspace is not secured by a railing.

The safety harness must be worn in such a way that the safety rope is connected to the safety harness and to a secure attachment point; provide shock absorbers if necessary.

Safety harnesses must only be used by personnel who have been specifically trained to use them.

### Safety shoes



Safety shoes protect the feet from crushing, falling parts and prevent slipping on a slippery floor.

## 3 Transport and storage

### 3.1 Delivery of the air handling unit

#### 3.1.1 Complete and partial units

Upon delivery, check the air handling unit for transport damage and completeness, ↪ *Chapter 3.2 'Delivery check' on page 10*.

The X-CUBE compact air handling unit (AHU) is supplied fully pre-assembled; if required, three-part devices (with split base frame) can be disassembled on site, e.g. for installation in the mounting space, ↪ *Chapter 4.4 'Removal of AHU casing units' on page 19*.

The AHU is screwed onto either a square timber frame or a single use pallet for transport.



*External components may be shipped unassembled to protect them from getting entangled with lifting eyes while being moved.*

#### 3.1.2 Symbols on the packaging

Lashing points are marked on the packaging. Be sure to follow them when you are moving the unit.



*The packaging may also carry other symbols, notes, and information. Be sure to take notice of them.*

#### Lashing point



*Fig. 3: Lashing point*

Always use a central lashing point for lifting and moving the air handling unit to ensure that it remains stable and cannot tip, slip, swing or fall unintentionally.

### 3.2 Delivery check

**Sharp edges, sharp corners and thin sheet metal parts**

#### CAUTION!

**Danger of injury from sharp edges, sharp corners and thin sheet metal parts!**

Sharp edges, sharp corners and thin sheet metal parts of the heat exchanger or of the cooling or heating coil may cause cuts or grazes.

- Be careful when working on these components.
- Wear protective gloves, safety shoes and a hard hat.

Check delivered items immediately after arrival for transport damage and completeness. In case of any damage or an incomplete shipment, contact the shipping company and your supplier immediately. If any parts are missing, have the driver confirm them on the consignment note.

Otherwise the manufacturer will not accept any liability.



*See the notes on shipping damage on the packaging or in the shipping papers.*

For any claims it is necessary that you follow the procedure below. In each of the following cases do contact TROX before you start installing a unit.

#### The packaging has been damaged

- Unpack the goods in the presence of the person who has delivered the goods and have them confirm the damage on the shipping order.
- Photograph the damage.
- Report the damage to TROX immediately.

#### No external damage to packaging, contents damaged.

- Photograph the damage.
- Report the damage to TROX immediately in writing.
- Note that shipping damage must be reported within four days of delivery.

### 3.3 Moving packages

#### 3.3.1 Safety notes regarding transport

##### Improper transport equipment

###### **WARNING!**

###### **Risk to life from using improper transport equipment!**

If packages are lifted without adequate transport equipment and if they are not properly secured, they may fall off and lead to fatal injuries.

- Move components only in the position in which they are to be installed.
- Stand clear of suspended loads.
- Do not move additional loads on top of a package.
- Use only the intended lashing points.
- Make sure that no load is imposed on pipes, ducts or cables.
- Use only approved lifting gear and slings that are suitable and sufficient for the load to be carried.
- Do not tie ropes and chains or make knots or place them on sharp edges.
- Use lifting equipment only to lift packages or units, not to push or pull them.
- Ensure that ropes, belts and chains do not twist.
- Ensure that transport equipment has been correctly assembled, fastened and secured before you use it to lift anything.
- Secure all doors, dampers and panels.
- Move packages without any jerky movements and put them down when you leave your work-place.
- Lifting eyes are designed for one-time use only and not for permanently suspending loads.
- Transport tubes are designed for one-time use only and not for permanently suspending loads.

##### Unbalanced loads and centre of gravity

###### **WARNING!**

###### **Risk of injury from falling or toppling loads!**

Loads may be unbalanced, i.e. the centre of gravity may not be obvious. If the load is not properly attached to the lifting equipment, it may topple and fall. Falling or toppling loads can cause serious injuries.

- Note that the centre of gravity is marked on each package.
- When you use a crane to move loads, ensure that the centre of gravity of the load is directly beneath the crane hook.
- Lift any load carefully and keep an eye on it to see whether it will stay in place. If required, change the lashing point(s).

##### Sticker indicating the centre of gravity

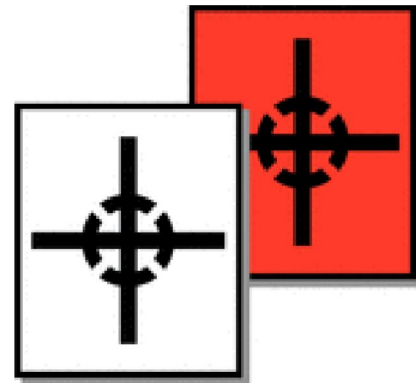

Fig. 4: Shipping stickers

Stickers on the packaging indicate the centre of gravity ( Fig. 4 ).

##### Sharp edges, sharp corners and thin sheet metal parts

###### **CAUTION!**

###### **Danger of injury from sharp edges, sharp corners and thin sheet metal parts!**

Sharp edges, sharp corners and thin sheet metal parts of the heat exchanger or of the cooling or heating coil may cause cuts or grazes.

- Be careful when working on these components.
- Wear protective gloves, safety shoes and a hard hat.

## Damage to goods being moved

### ! NOTICE!

#### Risk of damage to property due to the incorrect handling or lifting of units!

If you handle or move packages incorrectly, they may topple or fall. This can cause considerable damage to property.

- Do not put down packages hard and do not knock against them with force. Watch out for protruding parts.
- When you are moving units for outdoor installation, be careful that the thin metal roof is not damaged by the lifting gear.

1. ▶ Drive the forklift forward until the forks ( Fig. 5 /3) are fully between the square edge timber sections ( Fig. 5 /2) and protrude from underneath the base frame ( Fig. 5 /1) on the opposite side.
2. ▶ Ensure that the load cannot tip.
3. ▶ Slowly lift the load and start moving.

### 3.3.2 Moving packages with a forklift or pallet truck

Air handling units differ in weight and may have different lashing points. See the order-specific technical documents for details.

#### Personnel:

- Forklift driver

#### Protective equipment:

- Industrial safety helmet
- Protective clothing
- Safety shoes
- Protective gloves

### ! NOTICE!

#### Risk of damage to property from forklifts or pallet trucks!

Take proper precautions when you use a forklift or pallet truck to move or lift parts or components of an air handling unit as otherwise they may be damaged.

- If you want to use a forklift to lift a package without a base frame, you need to protect the casing units properly.

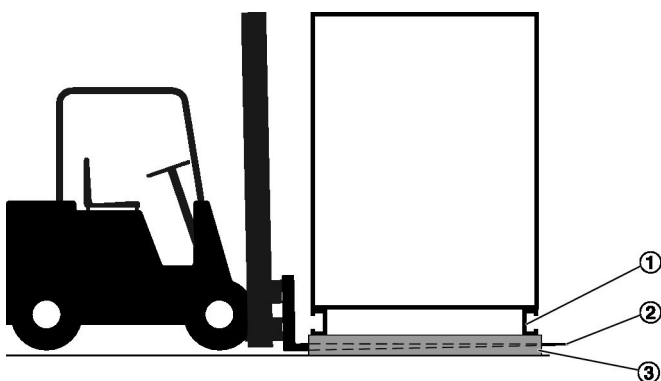

Fig. 5: Carrying load with a forklift

### 3.3.3 Moving packages with a crane

#### Moving units with transport tubes and ropes/chains

There are two ways to move AHU casing units: either with ropes/chains or with transport tubes.

Use only transport tubes with a length that is adequate for the AHU casing unit to be moved. The table below ( & 'Transport tubes' on page 13 ) shows the recommended minimum lengths for transport tubes.

#### Transport tubes

Overall width of AHU casing unit [mm]	Length of transport tube [mm]
612	1058
918	1364
1224	1670

The transport tubes are not included in the air handling unit supply package. Use only transport tubes that are suitable for the required load (see table & 'Moving units with transport tubes and ropes/chains' on page 13 ).

Designation	Outer diameter [mm]	Wall thickness [mm]	Max. weight of AHU casing unit [kg]
Seamless steel tube, S235J2H	48.3	5	≤ 1500

You may also use other tubes which are suitable for the same or a higher load.

#### Personnel:

- Crane driver

#### Protective equipment:

- Industrial safety helmet
- Protective clothing
- Hearing protection
- Safety shoes
- Protective gloves

#### ! NOTICE!

##### Risk of damage to property from a crane!

Take proper precautions when you use a crane to move or lift parts or components of an air handling unit as otherwise they may be damaged.

- Protect the edges of the AHU casing units with wood blocks.
- Spread the wire ropes or chains near the roof with a suitable device.

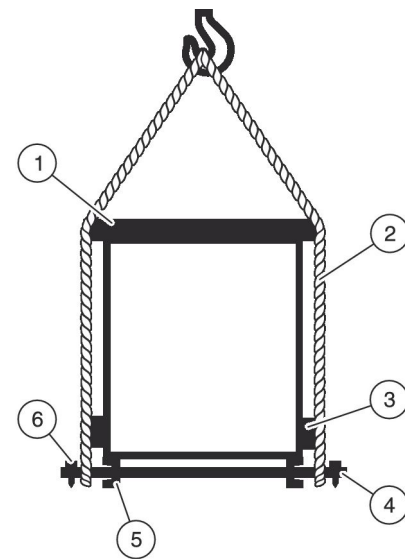

Fig. 6: Moving units with a crane and transport tubes

- ▶ Remove the plugs from the drilled holes in the base frame ( Fig. 6 /5) of the AHU casing unit.
- ▶ Push transport tubes ( Fig. 6 /4) through the drilled holes in the base frame.
- ▶ Place the loops of the ropes or chains ( Fig. 6 /2) around the ends of the transport tubes.



#### DANGER!

##### Danger of death from the fall of suspended loads!

Potentially fatal situations may occur if the chains or wire ropes slip off the transport tubes.

Ensure that the chains or ropes cannot slip.

- ▶ Protect the edges with wood blocks ( Fig. 6 /3).
- ▶ Spread the slings near the roof with a suitable device ( Fig. 6 /1).
- ▶ Ensure that the slings cannot damage the AHU casing unit.
- ▶ Suspend (distribute) the load symmetrically, i.e. in such a way that its centre of gravity is beneath the crane hook.
- ▶ Slowly lift the load and start moving.

## Moving units for indoor installation with a crane and lifting eyes/eye nuts and ropes/chains

### Without a spreader beam

#### Personnel:

- Crane driver

#### Protective equipment:

- Industrial safety helmet
- Protective clothing
- Hearing protection
- Safety shoes
- Protective gloves

### WARNING!

#### Danger of death from the fall of AHU casing units.

If you overload lashing points or lifting gear, the load may fall down. You or others could be killed.

- Use lifting eyes only to move AHU casings for indoor installation, and only for casing units up to a maximum weight of 1500 kg.



We recommend using a chain hoist and spreader beam if there are six or more lashing points.

- ▶ Maintain an angle greater than 45° between the rope or chain and the top of the unit.
- ▶ Do not spread slings by more than 60°.
- ▶ Ensure that the slings cannot damage the AHU casing unit.
- ▶ Suspend (distribute) the load symmetrically, i.e. in such a way that its centre of gravity is beneath the crane hook.
- ▶ Slowly lift the load and start moving.

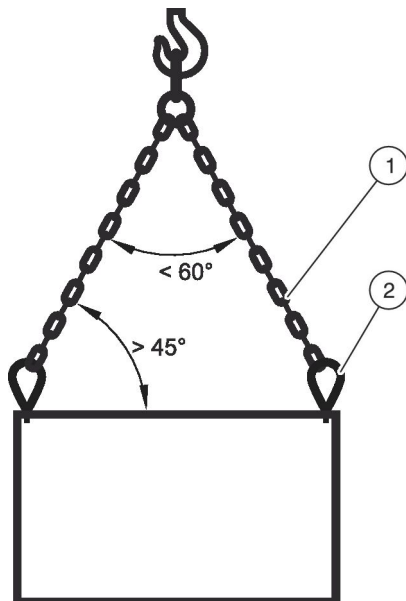

Fig. 7: Moving units with a crane and lifting eyes or eye nuts (without a spreader beam)

- ▶ Remove the covers from the threaded holes in the top corners of the AHU casing unit.
- ▶ Insert all lifting eyes or eye nuts ( Fig. 7 /2) completely into the threaded holes.
- ▶ Hook the slings ( Fig. 7 /1) into the lifting eyes or eye nuts.

**With a spreader beam**

**Personnel:**

- Crane driver

**Protective equipment:**

- Industrial safety helmet
- Protective clothing
- Hearing protection
- Safety shoes
- Protective gloves

**⚠ WARNING!**

**Danger of death from the fall of AHU casing units.**

If you overload lifting eyes, the load may fall down. You or others could be killed.

- Use lifting eyes only to move AHU casings for indoor installation, and only for casing units up to a maximum weight of 1500 kg.

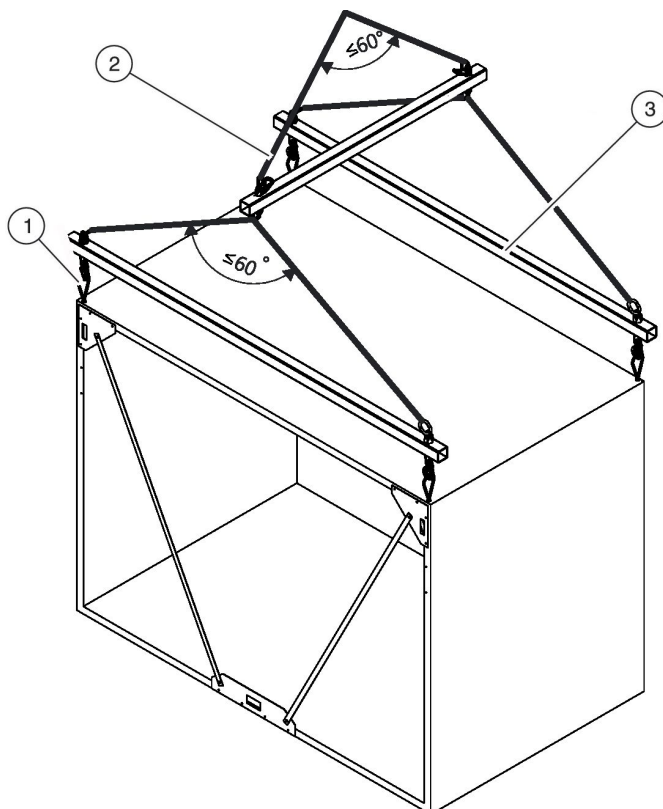

Fig. 8: Moving units with a crane and lifting eyes or eye nuts (with a spreader beam)

1. ▶ Remove the covers from the threaded holes in the top corners.
2. ▶ Insert all lifting eyes or eye nuts ( Fig. 8 /1) completely into the threaded holes.
3. ▶ Hook the spreader beams ( Fig. 8 /3) into the lifting eyes or eye nuts.

4. ▶ Connect the spreader beams with chains ( Fig. 8 /2).
5. ▶ Do not spread slings by more than 60°.
6. ▶ Suspend (distribute) the load symmetrically, i.e. in such a way that its centre of gravity is beneath the crane hook.
7. ▶ Slowly lift the load and start moving.

**3.4 Storing packages**

If you have to store packages temporarily:

- Do not store outdoors.
- Set down on even ground.
- Store in a dry and dust free place.
- Do not expose to any aggressive gases or liquids.
- Store away from direct sunlight.
- Do not expose to sudden temperature changes or excessive temperatures.
- Storage temperature -10 °C to +50 °C, with no risk of condensation.
- Store units only with packaging (original or any other suitable protective packaging).
- Protective packaging has to allow for sufficient ventilation on all sides as otherwise condensation will form.
- Close any connection openings.
- If a unit has to be stored for more than 3 months, regularly check the general condition of all parts and of the packaging. Refresh corrosion protection, if necessary.

**! NOTICE!**

**Risk of damage to property due to white rust!**

Galvanised parts wrapped in plastic without adequate ventilation are susceptible to corrosion, especially if moisture is present.

- Remove protective film, if any.
- Store all units in a dry place.

**i Note!**

Packages may contain additional important information on storage requirements. Be sure to read it.

**3.5 Unpacking**

Unless packaging or the contents have been damaged while in transit, remove the packaging only when you are ready to start installation ↪ Chapter 3.2 'Delivery check' on page 10 .



## ENVIRONMENT!

### **Risk of harm to the environment due to incorrect disposal of goods and packaging!**

Packaging materials can, in many cases, be reconditioned and recycled. Incorrect disposal of packaging can harm the environment.

- Dispose of packaging materials in an environmentally friendly manner in accordance with the local waste disposal regulations.
- If necessary, employ a specialist disposal company to dispose of the packaging.



## 4 Setup and assembly

The AHU must be assembled after delivery and the protective devices must be set up. The X-CUBE compact air handling unit (AHU) is supplied fully pre-assembled; if required, three-part devices (with split base frame) can be disassembled on site, e.g. for installation in the mounting space, see *Chapter 4.4 'Removal of AHU casing units' on page 19*.

### 4.1 Safety notes regarding setup and assembly

#### Setup and assembly

##### WARNING!

##### **Risk to life from incorrect setup and assembly!**

The incorrect setup and assembly of AHU casing units can lead to potentially fatal situations and cause considerable damage to property. Incorrect setup and assembly will also impair the function of the unit.

- Air handling units must only be set up and assembled by HVAC technicians.

#### Working at height

##### WARNING!

##### **Risk of a fall when you work at height!**

Working at height without using any fall protection equipment, or using unsuitable or damaged equipment to get up to where you work at height, may lead to yourself or others falling from height; people on the ground may be at risk from falling parts or tools. This can cause serious or even fatal injuries.

- Only use equipment that is suitable, stable and strong enough for the job, maintained and checked regularly.
- Stop materials or objects from falling.
- Wear safety shoes, protective clothing and a hard hat.
- Wear a safety harness.

#### Interconnecting units and systems

##### WARNING!

##### **Risk of injury from interconnecting different units or systems!**

Connecting an air handling unit to other units or systems (e.g. ductwork, pumps, refrigeration systems) can lead to dangerous situations and eventually cause serious or even fatal injuries.

- If you have to connect other units or systems to the air handling unit, connect them professionally.
- The system owner/HVAC contractor is responsible for the planning and installation of any additional safeguards.

#### Sharp edges, sharp corners and thin sheet metal parts

##### CAUTION!

##### **Danger of injury from sharp edges, sharp corners and thin sheet metal parts!**

Sharp edges, sharp corners and thin sheet metal parts of the heat exchanger or of the cooling or heating coil may cause cuts or grazes.

- Be careful when working on these components.
- Wear protective gloves, safety shoes and a hard hat.

### 4.2 Requirements for the installation location

#### 4.2.1 Requirements for indoor installation

##### Installation room

Air handling units designed for indoor installation have to be installed in a room that meets the following requirements:

- The room has been designed in compliance with the applicable building regulations and is suitable for the technical systems to be installed. National standards for plant rooms may also apply.
- The room is:
  - clean
  - dry
  - free from conductive dust particles
  - free from strong electromagnetic fields
  - free from aggressive atmospheres
  - free from frost
  - fitted with a functioning drainage system
- There is sufficient clearance for installing, operating, servicing, and repairing the AHU and all its parts. The maintenance access is at least as deep as the unit.

- The structure on which the air handling unit is to be installed must be suitable for the weight and have a level surface (see the order-specific data sheet for the air handling unit).
- Do not use the air handling unit as a structural element or as a roof for a building.
- Do not use the air handling unit in potentially explosive atmospheres.

## Escaping water

### ! NOTICE!

#### **Risk of damage to property from escaping water!**

If the water system is not tight, water may escape and cause considerable damage to property.

- Ensure that liquids are channelled away and to a collection device.

## Condensation

### ! NOTICE!

#### **Condensation can cause physical damage!**

If outdoor temperatures are low and the system is not running, condensation may occur in the air handling unit due to moist air in the building.

- Shut off the ducts with dampers or install an air heater to prevent condensation in the air handling unit.

## Installation room foundation

The installation room foundation must fulfil the following requirements:

- It is horizontal, flat and robust, made of concrete; alternatively, a supporting structure made of steel may be used.
- The frequency of the supporting structure, particularly of a steel structure, is sufficiently different from the excitation frequency of movable components, such as fans, motors, pumps or refrigerant condensers.
- For air handling units with a condensate drain, the supporting structure is at least as high as the drain trap, see [Chapter 5.3 'Connecting the condensate drain'](#) on page 28
- If additionally structure-borne noise is to be attenuated (e.g. by rubber or elastomer sheets underneath the air handling unit), be sure to exactly align all AHU casing units (check for door closure, properly sealed joints).

## 4.2.2 Requirements for outdoor installation

### Installation location

For outdoor installation please note:

- Do not use the air handling unit in potentially explosive atmospheres.
- The installation location has to be
  - free from conductive dust particles
  - free from strong electromagnetic fields
  - free from aggressive atmospheres
  - fitted with a functioning drainage system
- The structure on which the air handling unit is to be installed must be suitable for the weight and have a level surface (see the order-specific data sheet for the air handling unit).
- There is sufficient clearance for installing, operating, servicing, and repairing the AHU and all its parts. The maintenance access has to be at least as deep as the unit.
- Make sure that the installation location meets local regulations to prevent the fall of people, and of tools and other objects.
- Use suitable fall arrest equipment.
- Prevent unauthorised individuals from accessing AHU casing units.
- Make sure that authorised individuals can access AHU casing units safely.
- Keep the structural properties in mind and make sure the maximum roof load is not exceeded; do not neglect the effects of weather on the unit (rain, snow, wind, sun etc.).
- Only a skilled qualified professional must connect the air handling unit to an external switch cabinet and prevent the cables from the effects of weather (rain, snow, wind, sun etc.).
- All operating fluid pipes and hoses and the AHU components to which they are connected must be frost-proof.
- Do not use the air handling unit as a structural element or as a roof for a building.

### Foundation of the outdoor installation area

- The information regarding the foundation of the installation room applies, see ['Installation room foundation'](#) on page 18
- For roof installation, check the load capacity and support structure of the roof; consult an engineer if necessary.
- The entire air handling unit must be supported by a continuous steel structure.
- The steel girders must be designed for a maximum deflection of L/500 under load (L = girder length). A maximum deflection of 10 mm under load must not be exceeded.
- Waterproof the edge of the roof under the air handling unit and also any connections penetrating the roof.

- Insulate the plinth structure (by others) to prevent condensation.
- In areas with heavy snowfall, choose an installation location where snow will not affect the operation of the air handling unit. Make sure that the supporting structure is high enough.

### Escaping water

#### ! NOTICE!

#### Risk of damage to property from escaping water!

If the water system is not tight, water may escape and cause considerable damage to property.

- Ensure that liquids are channelled away and to a collection device.

### 4.3 Preventing vibration and structure-borne noise

Anti-vibration elements or a noise insulating layer underneath the air handling unit may help to reduce the transmission of vibration from the air handling unit to the supporting structure:

- If the air handling unit is to be installed on level ground with no special requirements regarding structure-borne noise insulation, we recommend placing rubber or elastomer sheets between the air handling unit and the foundation.
- For noise insulation, compare the requirement to the sound power level of the air handling unit (see order-specific data sheet for the air handling unit) and have the necessary measures determined by an acoustics engineer.
- Use splitter sound attenuators if necessary.

#### ! NOTICE!

#### Risk of damage to the AHU

Anti-vibration elements or a noise insulating layer must not affect the structural safety of the AHU. Ensure the following:

- Use a sufficient number of anti-vibration elements and noise insulating layers and place them correctly as otherwise the frame may sag.
- Keep in mind that the various AHU casing units differ in weight; this must not lead to any height differences in the overall unit.

We recommend you to have noise insulating layers (including material and layout plan) selected and sized by an expert company.

### 4.4 Removal of AHU casing units

The X-CUBE compact air handling unit (AHU) is supplied fully pre-assembled; if required, three-part devices (with split base frame) can be disassembled on site, e.g. for installation in the mounting space.

#### Personnel:

- HVAC technician

#### Protective equipment:

- Industrial safety helmet
- Safety shoes

#### ! NOTICE!

#### Risk of damage to property from incorrect assembly!

Be sure to assemble the AHU casing units correctly as otherwise the condensate drain may be damaged.

- Protect the condensate drain from damage.

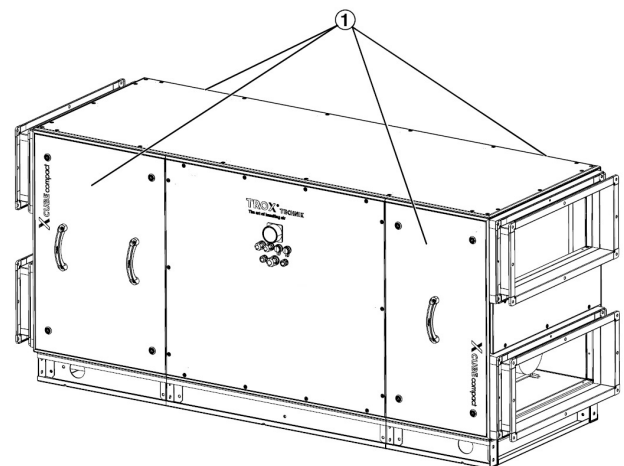

Fig. 9: Opening XCC inspection access doors

1. ▶ Open the inspection access panels ① on the operating side and the rear side of the two outer AHU casing units. Store the inspection access panels in such a way that they are protected from damage.

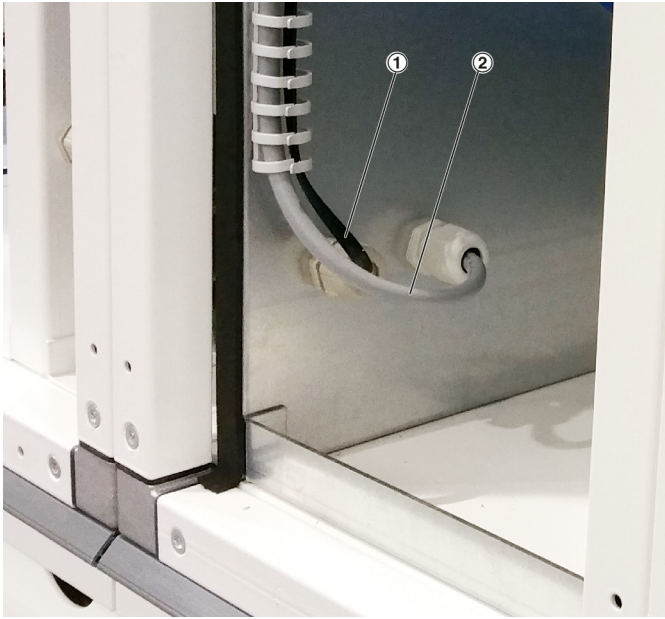

Fig. 10: Connecting cables

- ① Bus line
  - ② Connecting cable to fan
2. ▶ Two connecting cables each run through the partition walls of the AHU casing units and must be pulled back into the main casing unit. To do so, disconnect the connecting cable from the fan and disconnect the bus line in the associated FAN IO.

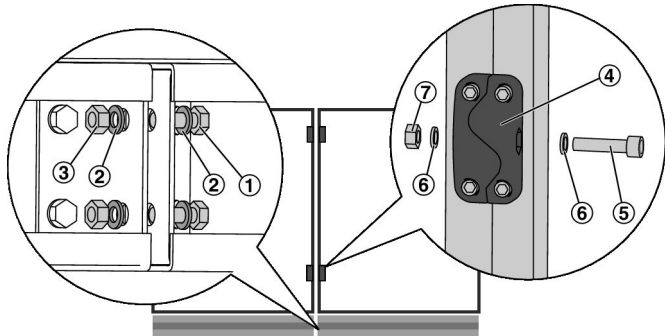

Fig. 11: Disconnecting the AHU connection points

- ① Hexagon head screws
  - ② Washers
  - ③ Nuts
  - ④ Module connectors
  - ⑤ Allen screws
  - ⑥ Conical spring washers
3. ▶ Loosen the casing unit connectors and screw connections on the base frame.
- ⇒ The AHU casing units can then be transported separately from each other.

Assembly of the individual AHU casing units:  
 ↪ Chapter 4.5 'Setting up and assembling the air handling unit' on page 20 .

The wiring of the connecting cable of the fans may be carried out only by a qualified electrician.

## 4.5 Setting up and assembling the air handling unit

### 4.5.1 Setting up the AHU or AHU casing units

#### Checking the seals on AHU casing units

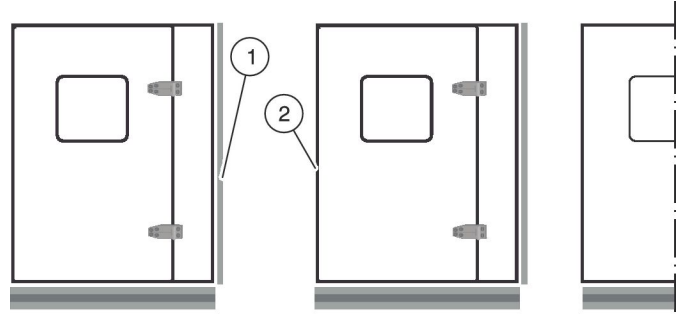



Fig. 12: Seals on AHU casing units

Where two AHU casing units are to be joined, a perimeter seal ( Fig. 12 /1) is provided. Note that only one of the units to be joined is fitted with a seal. The other unit does not have a seal ( Fig. 12 /2).

▶  *Compressed seals will recover fully to their original state about 60 minutes after the transport protection devices have been removed.*

Check that the seals are complete and intact and that they seal properly.

#### Setting up AHU casing units

##### Personnel:

- HVAC technician

##### Protective equipment:

- Industrial safety helmet
- Safety shoes
- Protective gloves

Slide plates ( Fig. 13 /3) considerably simplify the process of positioning the AHU casing units ( Fig. 13 /1) on a surface with a high friction coefficient, such as rubber or elastomer sheets ( Fig. 13 /4).



The arrangement of the AHU casing units is given in the order-specific approval drawing.

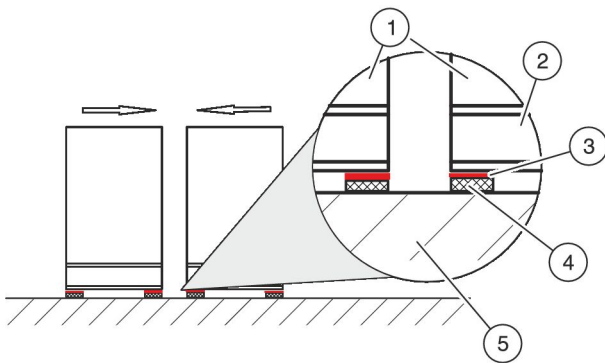

Fig. 13: Unit arrangement with anti vibration elements

1. ▶



The rubber or elastomer sheets are compressed to a greater or lesser degree depending on the weight of each AHU casing unit. Be sure to adjust any resulting height differences.

Position the slide plates ( Fig. 13 /3, by others) under the base frames ( Fig. 13 /2) of the AHU casing units ( Fig. 13 /1).

2. ▶



For outdoor installation: Ensure that there is still enough space to attach the self-adhesive seal, see 'Additional assembly steps for outdoor units' on page 22 .

Move the AHU casing units as close together as possible.

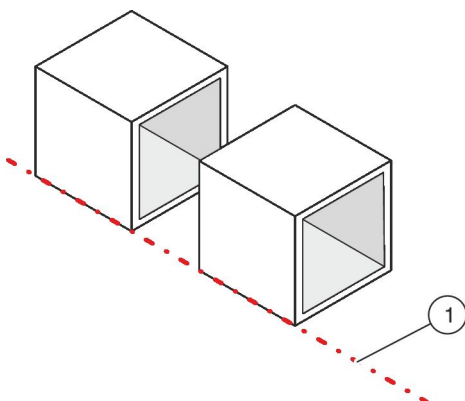

Fig. 14: Aligning AHU casing units

3. ▶ Align the AHU casing units such that they are flush with one another ( Fig. 14 /1).

### Setting up units with a base frame

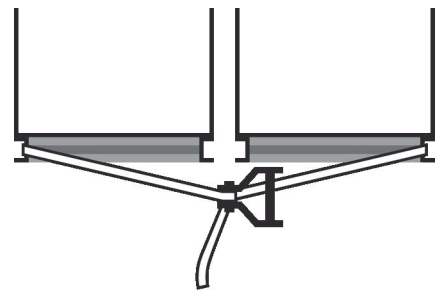

Fig. 15: Attaching a ratchet strap

1. ▶ Attach a ratchet strap to the base frames of two AHU casing units ( Fig. 15 ).
2. ▶ Tighten the ratchet strap.
  - ⇒ The AHU casing units come closer together as you tighten the strap around the base frames.

### 4.5.2 Before assembly

#### Before assembly

- Remove all transport tubes and transport protection devices from the AHU casing units.
- Have all the required tools ready.
- Have all the applicable documents at hand.
- Remove all separately supplied materials and accessories from the AHU casing units.



Compressed seals will recover fully to their original state about 60 minutes after the transport protection devices have been removed.

#### Required tools

- Drill or cordless drill driver
- Drill bit holder and bit set
- Allen key (size 3, 5, 6, 10)
- Slotted screwdriver, size 6
- Bits (Torx/Allen, T30))
- Open end spanner/ring spanner (head size: 6 and 10)
- Water pump pliers
- Ratchet straps or suitable lifting gear

## 4.5.3 Assembling AHU casing units

### Personnel:

- HVAC technician

### Protective equipment:

- Industrial safety helmet
- Protective clothing
- Hearing protection
- Safety shoes

### ! NOTICE!

#### Risk of damage to property from incorrect assembly!

Be sure to assemble the AHU casing units correctly as otherwise the condensate drain may be damaged.

- Protect the condensate drain from damage.

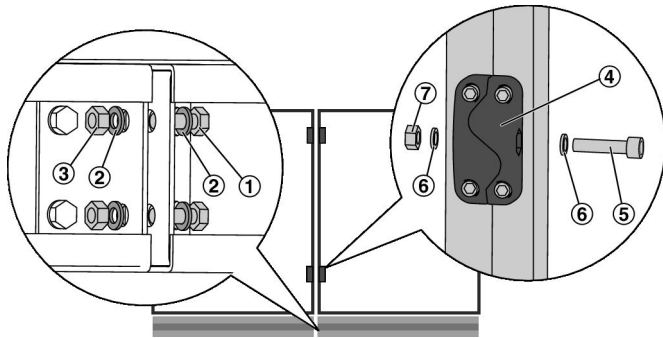

Fig. 16: Joining AHU casing units with screws/bolts

- ① Hexagon head screws
- ② Washers
- ③ Nuts
- ④ Module connectors
- ⑤ Allen screws
- ⑥ Conical spring washers

- ▶ Use screws/bolts to join the casing units at the base frame and at the module connectors.

## Additional assembly steps for outdoor units

### Personnel:

- HVAC technician

### Protective equipment:

- Safety harness
- Industrial safety helmet
- Protective clothing
- Hearing protection
- Safety shoes
- Protective gloves

### Materials:

- Roof
- Roof supports (left, centre, right)
- 4 x cheesehead screws
- 4 x ring seals
- Self-tapping screws

For outdoor installation proceed as follows:

### Roof assembly

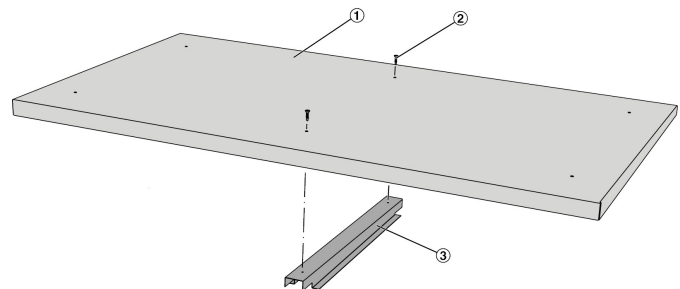

Fig. 17: Fixing the central roof support

- ▶ Fix the central roof support ( Fig. 17 /3) with self-tapping screws ( Fig. 17 /2) to the roof ( Fig. 17 /1).

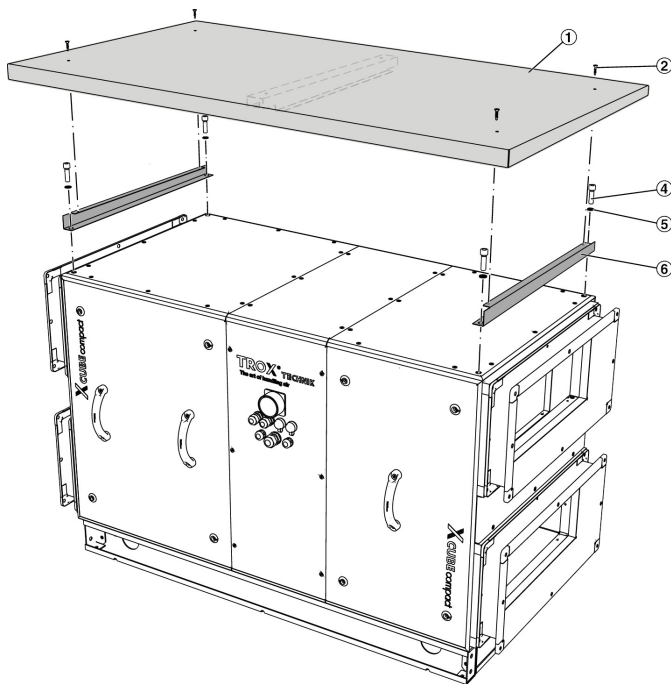

Fig. 18: Roof assembly

2. ▶ If any lashing points have been fitted to the top corners of the AHU, remove them now. Fix the left and right roof supports ( Fig. 18 /6) each with two cheesehead screws ( Fig. 18 /4) and seals ( Fig. 18 /5) to the top corners of the AHU.
3. ▶ Place the roof ( Fig. 18 /1) with the roof supports facing down onto the air handling unit and fix it with the self-tapping screws ( Fig. 18 /2).

**Fitting base frame plugs**

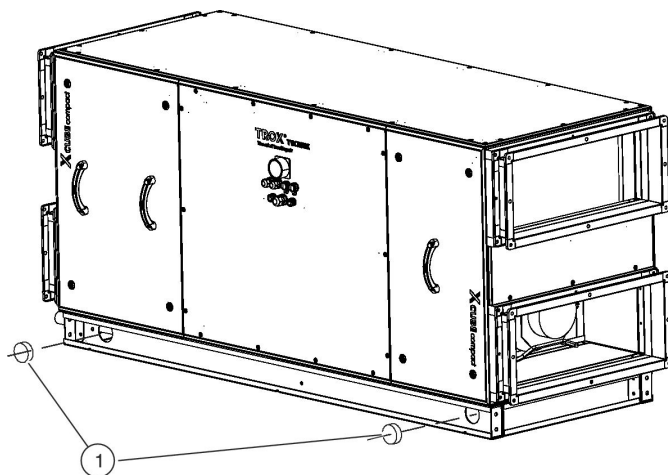

Fig. 19: Fitting plugs

4. ▶ Seal the transport openings in the base frame of the air handling unit with the plugs ( Fig. 19 /1) provided.
  - ⇒ This will prevent water from getting into outdoor units.

**Removing the noise insulating connectors**

**Personnel:**

- HVAC technician

**Protective equipment:**

- Industrial safety helmet
- Protective clothing
- Hearing protection
- Safety shoes

Noise insulating connectors are factory mounted. You may, however, have to remove the noise insulating connectors before you can install any accessories.

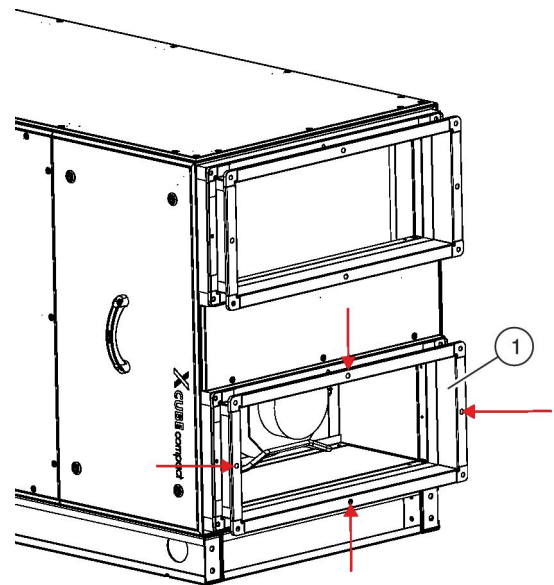

Fig. 20: Removing noise insulating connectors

- ▶ Remove the four Allen screws (M6x50) ( Fig. 20 /red arrows) from the noise insulating connector and take the noise insulating connector ( Fig. 20 /1) off.

## Installing the noise insulating connector

### Personnel:

- HVAC technician

### Protective equipment:

- Industrial safety helmet
- Protective clothing
- Hearing protection
- Safety shoes

Noise insulating connectors are factory mounted. If you have removed noise insulating connectors before installing any accessories you will have to mount the connectors again. In order to connect the air handling unit to the ducting you have to mount the noise insulating connector onto the supply air side of the air handling unit.

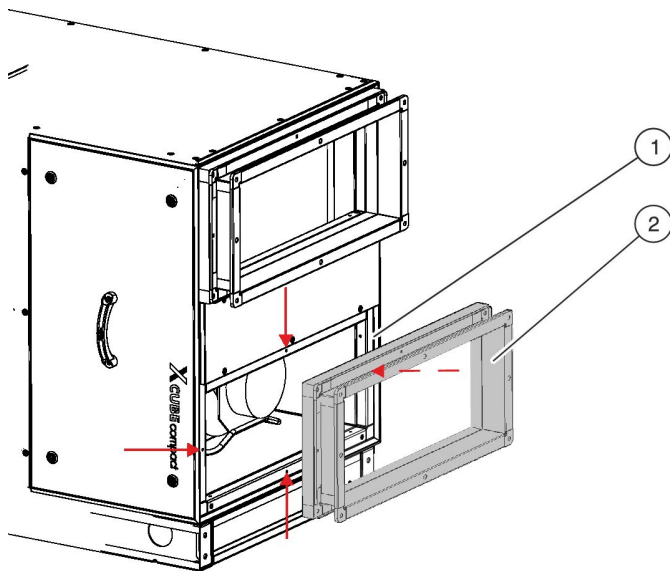

Fig. 21: Mounting noise insulating connectors

- ▶ Use four Allen screws (M6x50) to mount the noise insulating connector ( Fig. 21 /2) to the frame of the air handling unit ( Fig. 21 /1).

## Installing ducts

### Personnel:

- HVAC technician

### Protective equipment:

- Industrial safety helmet
- Protective clothing
- Protective gloves
- Safety shoes

- ▶ Ensure precise fit and avoid distortion when you connect the ducts.

**Note:** Any load on the noise insulating connector may impair the tight fit. Connect the duct in such a way that no loads are imposed on the connector; if necessary, slightly re-tighten the screws on the connector.

- ▶ Insulate ducts (including flexible connectors and connecting frames).
- ▶ For outdoor units: Protect ducts (including spigots and connecting frames) against the effects of weather.

## 4.5.4 Installing accessories

### Attaching an accessory module to the air handling unit

#### Personnel:

- HVAC technician

#### Protective equipment:

- Industrial safety helmet
- Protective clothing
- Hearing protection
- Safety shoes
- Protective gloves

Proceed as follows to attach an accessory module to the air handling unit:



i

If an accessory module was ordered together with the air handling unit, the supply air spigot ( Fig. 21 /2 ) has been factory mounted on the supply air side of the accessory module.

If there is not enough space to install the air handling unit and the accessory module in a line, you have to use a staggered arrangement. In this case two additional unit-specific spigots have to be ordered and mounted to the air handling unit and the accessory module ( ↪ 'Installing the noise insulating connector' on page 24 ).

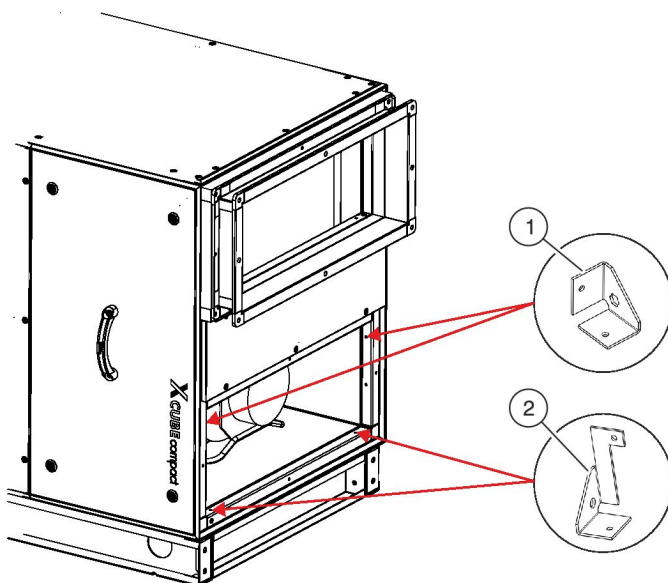

Fig. 22: Gusset plates

1. ▶ Screw-fix two standard gusset plates ( Fig. 22 /1 ) to the upper holes using the supplied screws.
2. ▶ Screw-fix two gusset plates with cut-out ( Fig. 22 /2 ) to the lower holes using the supplied screws.
3. ▶ Position the accessory module in such a way that the holes in the gusset plates are flush with the holes in the gusset plates of the air handling unit ( ↪ 'Setting up AHU casing units' on page 20 ).
4. ▶ Connect the accessory module to the earth; use the hexagon head screw ( Fig. 23 /3 ) on the lower gusset plate on the operating side for this purpose.

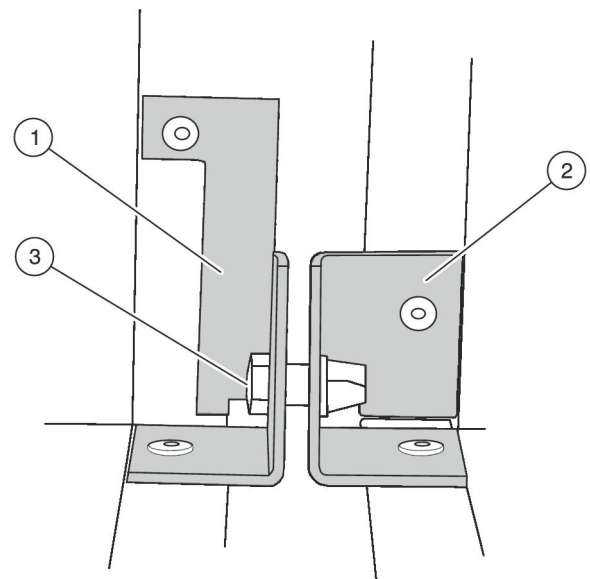

Fig. 23: Gusset plates

5. ▶ Connect the gusset plates of the air handling unit and of the accessory module ( Fig. 23 /1+2 ) with hexagon head screws ( Fig. 23 /3 ).



Fig. 24: Earth symbol sticker

6. ▶ Affix the earth symbol sticker ( Fig. 24 ) next to the earthed gusset plate.
  - ⇒ The accessory module has been mounted to the air handling unit.

## Mounting the roof onto accessory modules

### Personnel:

- HVAC technician

### Protective equipment:

- Industrial safety helmet
- Protective clothing
- Hearing protection
- Safety shoes
- Protective gloves

Proceed as follows to mount the roof onto the accessory module:

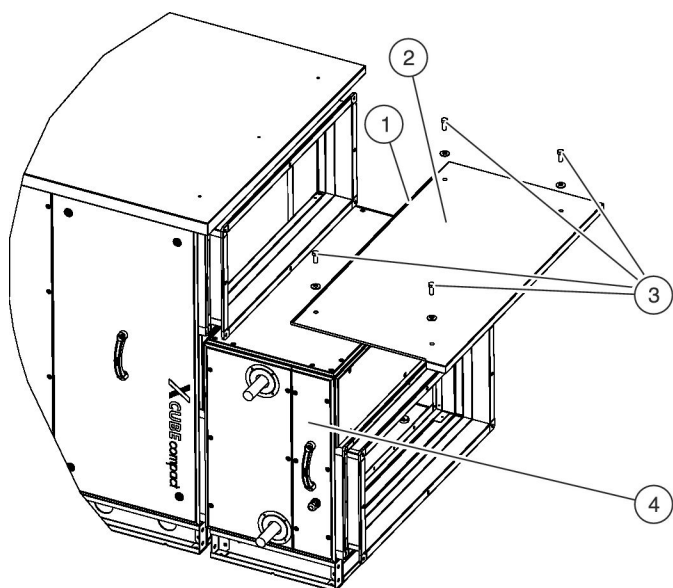

Fig. 25: Roof

1. ▶ Fit the seal ( Fig. 25 /1) between the roof ( Fig. 25 /2) and the accessory module ( Fig. 25 /4).
2. ▶ Use the four screws ( Fig. 25 /3) to screw-fix the roof ( Fig. 25 /1) onto the accessory module ( Fig. 25 /4).

## 5 Installation

### 5.1 Safety notes regarding installation

#### Incorrect installation

##### WARNING!

##### **Risk to life from incorrect installation!**

Incorrect installation can lead to potentially fatal situations and cause considerable damage to property.

- Only a skilled qualified electrician must connect the power supply.
- Any other installation job has to be carried out by an HVAC technician.

#### Hot surfaces

##### WARNING!

##### **Risk of injury from hot surfaces!**

The surfaces of components can get very hot during operation. Skin contact with hot surfaces causes severe skin burns.

- Professionally insulate pipes that connect condensers or heating coils.

#### Interconnecting units and systems

##### WARNING!

##### **Risk of injury from interconnecting different units or systems!**

Connecting an air handling unit to other units or systems (e.g. ductwork, pumps, refrigeration systems) can lead to dangerous situations and eventually cause serious or even fatal injuries.

- If you have to connect other units or systems to the air handling unit, connect them professionally.
- The system owner/HVAC contractor is responsible for the planning and installation of any additional safeguards.

#### Sharp edges, sharp corners and thin sheet metal parts

##### CAUTION!

##### **Danger of injury from sharp edges, sharp corners and thin sheet metal parts!**

Sharp edges, sharp corners and thin sheet metal parts of the heat exchanger or of the cooling or heating coil may cause cuts or grazes.

- Be careful when working on these components.
- Wear protective gloves, safety shoes and a hard hat.

### 5.2 Before installation

The following requirements must be met prior to installation:

- Have the applicable documentation at hand (  'Other applicable documentation' on page 3 )
- Ensure that the installation requirements are met (see the order-specific data sheet for the air handling unit).
- Have all the required tools ready.

## 5.3 Connecting the condensate drain

### Electric current

**⚠ WARNING!**

**Danger of death due to electric current!**

If electrical components come into contact with water, e.g. from a leak, you could be seriously or even fatally injured. Water can also cause damage to the air handling unit.

- Lay drainage pipes in such a way that they cannot be accidentally damaged by mechanical impact or by heat.

### Height of drain trap

**! NOTICE!**

**Risk of leakages due to incorrect installation!**

Do not connect the condensate drain to the sewerage system without a drain trap or with an unsuitable drain trap as this may result in air getting into the AHU.

- Use the AHU only with a suitable drain trap.
- Do not connect the drain trap to the drainage pipe; the water from the drain trap should flow to a gully.
- Use a different drain trap for each condensate drain. Do not connect condensate drains with each other.

Calculate the height of a drain trap as shown below.

**Symbol:**

- P - Pressure inside the air handling unit [Pa]; be sure to use a positive value for calculations; take the final differential pressure (filter etc.) into consideration
- 1.5 - Safety factor to compensate for pressure fluctuations in the system such as those resulting from rapidly closing dampers (applies only to positive pressure)
- GR - Base frame height = 110 mm
- R - Distance R [mm]; minimum distance between condensate drain (centre line) and floor
- H - Distance H [mm]; minimum distance between base frame lower edge and floor
- A - Distance A = 57 mm
- C - Distance C = 53 mm

### Negative pressure (extract air)

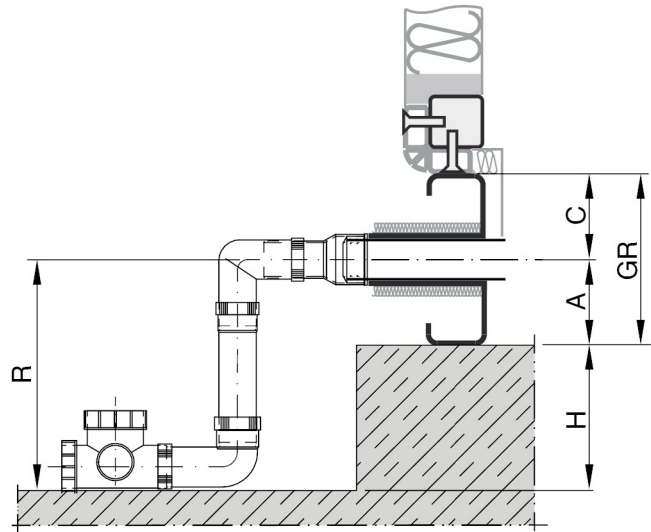

Fig. 26: Drain trap for negative pressure

Calculation to be used for negative pressure (2900 Pa max.):

- $R = P / 10 + C$   
R has to be at least 140 mm
- $H = R - A$

**Calculation example for X-CUBE compact with plate heat exchanger:**

Given data:

- P - 1800 Pa
- GR - 110 mm
- A - 57 mm
- C - 53 mm

$$R = 1800 \text{ Pa} / 10 + 53 \text{ mm} = \underline{233 \text{ mm}}$$

$$H = 233 - 57 = \underline{176 \text{ mm}}$$

**Positive pressure (supply air)**

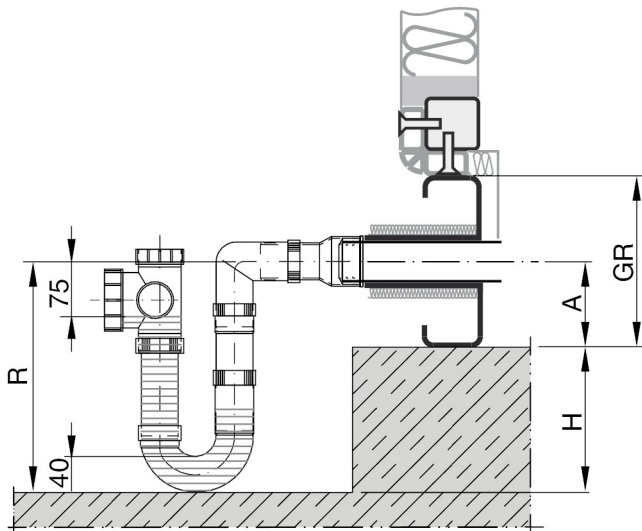

Fig. 27: Drain trap for positive pressure

Calculation to be used for positive pressure (1630 Pa max.):

- $R = P \times 1.5 / 10 + 115 (40 + 75)$   
Always cut or extend pipes by the same length. Do not cut a pipe by more than 155 mm.; R has to be at least 215 mm.
- $H = R - A$

**Calculation example for X-CUBE compact accessory heating coil/cooling coil:**

Given data:

P - 1500 Pa

GR - 110 mm

A - 57 mm

$R = 1500 \text{ Pa} \times 1.5 / 10 + 115 \text{ mm} = \underline{340 \text{ mm}}$

$H = 340 - 57 = \underline{283 \text{ mm}}$

**Connecting a drain trap**

**Personnel:**

- HVAC technician

**Protective equipment:**

- Industrial safety helmet
- Protective clothing
- Protective gloves
- Safety shoes

**! NOTICE!**

**Risk of damage to property from incorrect pipe connections!**

Take care to connect the pipes correctly as otherwise the pipes and the drain trap may be damaged beyond repair.

- Connect pipes in such a way that they are not affected by vibration and that no loads are imposed on them.
- If an AHU is installed outdoors, use suitable pipes and protect them from frost.

1. ▶ Calculate the height of the drain trap as shown above.

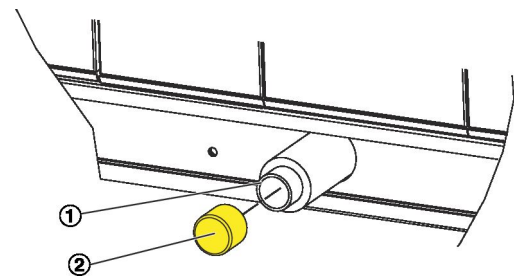

Fig. 28: Condensate drain

2. ▶ Remove the protective cap ( Fig. 28 /2) from each drain ( Fig. 28 /1) of the condensate drip tray.

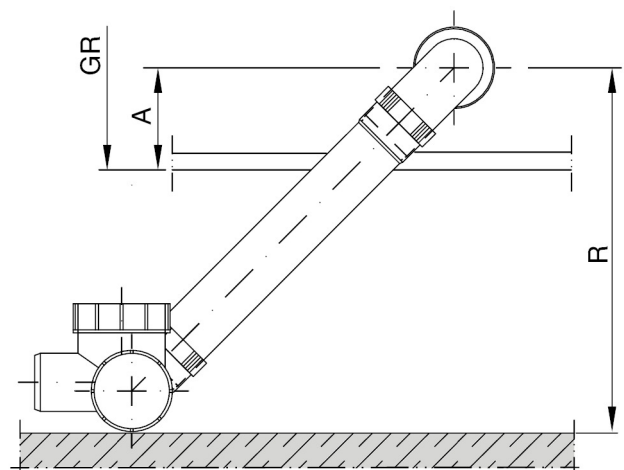

Fig. 29: Sloped pipe of a drain trap for negative pressure

3. ▶ Adjust the height of the drain tap based on the above calculation. Drain traps for negative pressure: Instead of shortening the pipe, you can install the drain trap such that it slopes.
4. ▶ Connect a drain trap to each condensate drain ( Fig. 28 /1).

Do not connect the drain trap to the drainage pipe; the water from the drain trap should flow to a gully.

Air handling units to be installed outdoors or in areas at risk of frost require frost protection for the drain trap.

☒☒ Connecting the heating coil/cooling coil

## 5.4 ☒☒ Connecting the heating coil/cooling coil

### Electric current

**⚠ WARNING!**

**Danger of death due to electric current!**

If electrical components come into contact with water or a water glycol mixture, e.g. from a leak, you could be seriously or even fatally injured. Water can also cause damage to the air handling unit.

- Lay connecting cables in such a way that they cannot be accidentally damaged by mechanical impact or by heat.
- Do not lay connecting cables across electrical components or switch cabinets as people may become entangled in them.

Connect heat exchangers in a counter flow arrangement unless a parallel flow arrangement has been specified by the manufacturer. Only a counter flow arrangement ensures that the calculated capacity is achieved.



*If you have to attach brackets or fasteners to the AHU panels or frame, use only those specially approved for your AHU as otherwise there is a risk of leakages.*

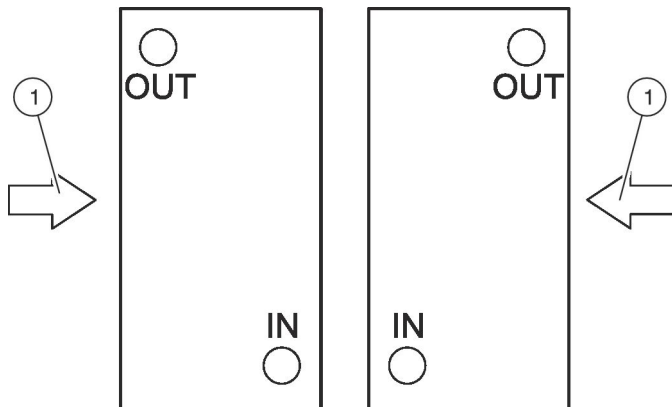

Fig. 30: Heat exchangers in a counter flow arrangement

1 Airflow direction



*Stickers on the connection side of the heat exchangers indicate the flow ( Fig. 30 /IN) and return connections ( Fig. 30 /OUT) for a counter flow arrangement.*

Connect slide-out heat exchangers and droplet eliminators with bends and detachable connections as otherwise you will not be able to withdraw them.

### Personnel:

- HVAC technician

### Protective equipment:

- Industrial safety helmet
- Hearing protection
- Protective clothing
- Protective gloves
- Safety shoes

**! NOTICE!**

**Risk of damage to property from incorrect pipe connections!**

Take care to connect the heat exchanger pipes correctly as otherwise the pipes may twist or become subject to adverse effects. This may eventually damage the heat exchanger beyond repair.

- Connect pipes in such a way that the heat exchanger is not affected by vibration and that no loads are imposed on it.
- If there is too much weight on a water pipe (by others), support the water pipe.
- Do not use the connection point of the heat exchanger as a fixing point for other parts.
- When you tighten thread connections, be sure to use a suitable tool (e.g. water pump pliers) to counter the tightening force as otherwise you may inadvertently damage the parts.
- If an AHU is installed outdoors, use suitable pipes and protect them from frost.
- Ensure that no air gets trapped in the pipes.

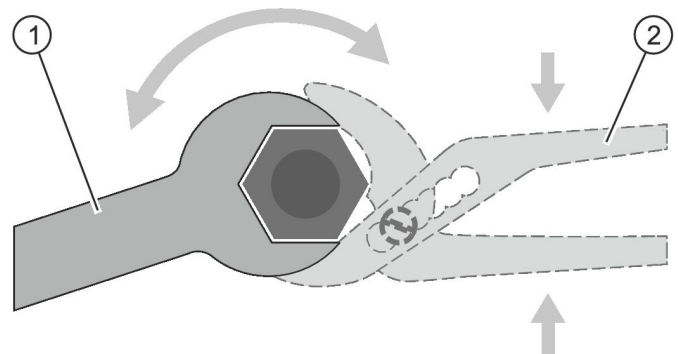

Fig. 31: Using water pump pliers to counter the tightening force

1. ▶ Hold the threaded pipe tail of the heat exchanger with water pump pliers ( Fig. 31 /2).
2. ▶ Hold the threaded pipe tail with the pliers while you use a spanner (hexagonal profile, Fig. 31 /1) to connect the heat exchanger to the pipework (pipework by others).

## 5.5 Connecting the air handling unit to the power supply

### Electrical connection

#### DANGER!

#### Danger of death due to electric current!

Danger of electric shock! Do not touch any live components!

- Only a skilled qualified electrician must connect the power supply.
- See the circuit diagram in the appendix to this manual, ↗ 'Other applicable documentation' on page 3.
- Lay connecting cables in such a way that they cannot be accidentally damaged by mechanical impact or by heat.
- Bridge all non-conductive joints, such as connecting frames, flexible connectors and anti-vibration elements, with an equipotential bonding cable.
- Earth the air handling unit according to the state of the art.
- Secure all connections so that they cannot come loose.
- When you connect any electrical components, follow the manufacturers' specifications, the local regulations and codes of good practice (DIN/VDE), and the general recommendations for avoiding electromagnetic interference,
- If an AHU is installed outdoors, do not neglect the effects of weather on the unit (rain, snow, wind, sun etc.).



*If you have to attach brackets or fasteners to the AHU panels or frame, use only those specially approved for your AHU as otherwise there is a risk of leakages. Avoid screw joints that pierce the outer shell of the unit; if you cannot avoid them, then at least seal them to prevent the ingress of water. The minimum protection level is IP 65.*



*The electrical wiring diagrams and terminal diagrams can be found in the appendix of this document.*

1. ▶ Connect the electrical components, such as the electric air heater, motor, and actuator.

If the AHU has been dismantled on site ↗ 19, e.g. for installation in the mounting space, the electrical connecting cables to the fans must be re-established and the bus line must be reconnected to the respective FAN IO.

2. ▶ Include the air handling unit in the equipotential bonding arrangement.
3. ▶ Test protective conductors and insulation resistance to EN 60204 (VDE 0113). Take the appropriate safety precautions!

## 5.6 Integrating the air handling unit with the central BMS

It is the duty of the system owner/HVAC contractor to integrate the air handling unit with the building services and to ensure conformity, ↗ 'System owner's obligations' on page 8.

## 5.7 Connecting the air handling unit to your PC or local network

### Network or PC

#### Personnel:

- HVAC technician

#### Protective equipment:

- Industrial safety helmet
  - Hearing protection
  - Protective gloves
  - Protective clothing
  - Safety shoes
- ▶ Connect one end of the network cable to the AHU and the other end to your PC or local network.

Connecting the air handling unit to your PC or local network

## Cable entry points on the X-CUBE compact



Fig. 32: Cable entry points below the mains isolator

- ① Mains isolator
- ② Bus connection, input/output
- ③ Bus connection, input/output
- ④ Service interface of touch panel
- ⑤ Service interface of TCP/IP network
- ⑥ Fault messages etc.
- ⑦ Main connection of unit (voltage supply)
- ⑧ Signal line, e.g. for faults

### ! NOTICE!

#### Risk of damage to property from incorrect use

The service interfaces of the touch panel ( Fig. 32 /4) and TCP/IP network ( Fig. 32 /5) are intended for temporary use (e.g. service).

When not in use, protect the service interfaces from the weather by fitting caps.

If the device is used for a long period of time, it may be damaged by moisture, especially if it is installed outdoors.

The permanent and professional installation of the bus connecting cables is carried out at the inputs and outputs of the control master using the existing cable penetrations as cable glands.

## Modbus RTU

The Modbus-RS485 interface can be used to connect the AHU to a remote terminal unit (RTU). This allows you to display measurement values and to adjust set-point values via an external BMS or CTS.

The following bus interfaces are also available:

- Modbus RTU
- Modbus TCP/IP
- Integral web server
- BACnet
- LON (accessory)

## Personnel:

- Skilled qualified electrician

## Protective equipment:

- Industrial safety helmet
- Hearing protection
- Protective gloves
- Protective clothing
- Safety shoes

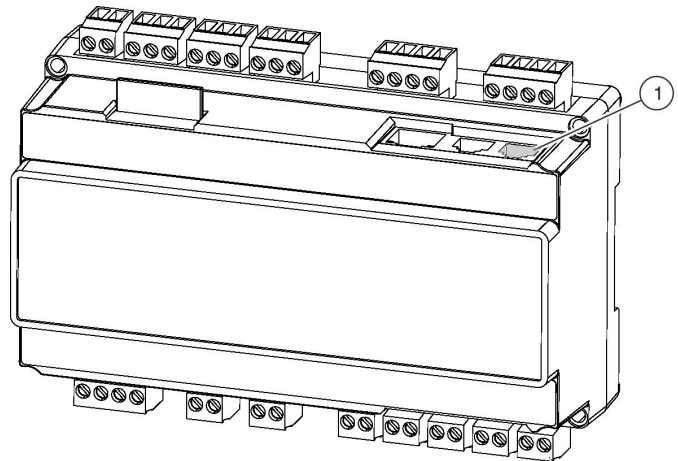

Fig. 33: Modbus RS485 interface

- ▶ Use the Modbus-RS485 interface ( Fig. 33 /1) to connect the X-CUBE control master to a remote terminal unit (RTU).



## 6 Initial commissioning

### 6.1 Safety notes regarding initial commissioning

#### Incorrect initial commissioning

#### WARNING!

##### **Risk to life from incorrect initial commissioning!**

Incorrect initial commissioning can lead to potentially fatal situations and cause considerable damage to property.

- Only skilled qualified electricians must work on the electrical system and on motors.
- All other initial commissioning steps must be carried out by an HVAC technician.

#### Inspection access panels on the discharge side

#### CAUTION!

##### **Risk of injury from a strong airflow on the discharge side of fans!**

When you open an inspection access panel on the discharge side of the fan, the pressure of the airflow may cause the panel to suddenly swing open until it is caught by the safety catch. You could be injured.

- Be careful when you open inspection access panels on the discharge side.

#### Sharp edges, sharp corners and thin sheet metal parts

#### CAUTION!

##### **Danger of injury from sharp edges, sharp corners and thin sheet metal parts!**

Sharp edges, sharp corners and thin sheet metal parts of the heat exchanger or of the cooling or heating coil may cause cuts or grazes.

- Be careful when working on these components.
- Wear protective gloves, safety shoes and a hard hat.

### 6.2 Before initial commissioning



*If any accessories have been installed be sure to follow the installation and commissioning instructions for those accessories.*

The air handling unit has been erected, assembled, and installed according to this manual.

Before initial commissioning, check the casing and the following parts for damage and completeness:

- Inspection access panels
- Seals
- Handles and levers
- Connections
- Panels

Before initial commissioning:

- Remove protective film, if any
- Check the unit for leakages
- Check inspection access panels for function and tolerances
- Set up the centrifugal fan
- Insert the filters, ↪ *'Inserting filters' on page 34*
- Set up the heating coil/cooling coil, ↪ *'Commissioning the heating coil/cooling coil' on page 34*
- Set up the multileaf dampers, ↪ *'Setting up multileaf dampers' on page 35*
- Set up the rotary heat exchanger, ↪ *'Setting up the rotary heat exchanger' on page 36*
- Set up the plate heat exchanger, ↪ *'Setting up the plate heat exchanger' on page 37*
- Remove the protective caps from the condensate drains and connect the drain trap,

## 6.3 Setting up and adjusting AHU casing units

### 6.3.1 Filter

#### Inserting filters

##### Personnel:

- HVAC technician

##### Protective equipment:

- Industrial safety helmet
- Protective clothing
- Protective gloves
- Safety shoes



- Filters may become contaminated due to ongoing construction work in the building which is why we recommend that you replace all filters after the construction phase and initial commissioning.
- Do not operate the air handling unit without a filter.
- One spare filter element should always be available such that the air handling unit does not have to be switched off. Store filters in a dry place, free from dust, so that they will not be contaminated or damaged. Do not use filters beyond the use before date. Original TROX filters carry a sticker on the frame with both the use before date and information on how to order replacements.

1. ▶ Ensure that the filters are intact.



*Defective filters may become torn while in use and will then no longer be effective.*

2. ▶ Remove any dust from all parts that are in upstream direction before the filter.



*Clean the air handling unit and ventilation ducts before you install any filter of class F9 or higher.*

3. ▶ Fit filters into the installation subframe and fix them with the clamping elements. Make sure that they are tightly seated.

⇒ The filter has been set up.

### 6.3.2 Heating coil/cooling coil

#### Operating fluids with glycol



##### WARNING!

##### Health risk from operating fluids that contain glycol!

The operating fluids in the heating coil and cooling coil contain glycol, which can damage your health if it comes into contact with your skin, if you swallow it or if you inhale the vapour or mist.

- Avoid contact with operating fluids that contain glycol.
- Work must only be carried out by HVAC technicians or the TROX Technical Service .
- Do not eat, drink or smoke while handling operating fluids that contain glycol.
- Wash your hands when you interrupt or finish your work.
- If you have come into contact with an operating fluid that contains glycol, follow the first aid instructions given on the safety data sheet for the operating fluid.
- When you have to handle an operating fluid that contains glycol, wear the personal protective equipment specified in the safety data sheet for the operating fluid.

#### Commissioning the heating coil/cooling coil

##### Personnel:

- HVAC technician

##### Protective equipment:

- Industrial safety helmet
- Protective clothing
- Hearing protection
- Protective gloves
- Safety shoes



*Ensure that the maximum pressure values given in the technical data are not exceeded.*

*Use appropriate measures to protect the water system from frost. Frost protection can be achieved with a water glycol mixture or with a special frost protection device.*

1. ▶ Ensure that the flow and return connections are correct.
2. ▶ Check that fittings are correctly installed.
3. ▶ Flush the system to remove any contamination.
4. ▶ Open vents (unless automatic vents have been installed).

## 5. ▶



For glycol water mixtures we recommend ready-to-use formulations. See the order-specific air handling unit data sheet from TROX for the mixing ratio.

The correct mixing ratio is important:

- Too much glycol will impair performance
- Too little glycol may lead to frost damage

.

Only use one of the following glycols for the air handling unit:

- Propylene glycol
- Ethylene glycol

Slowly pour the operating fluid at the lowest point into the heating coil/cooling coil. As you fill the system, check that all external and internal screw joints and connections are tight.

6. ▶ Vent the heating coil/cooling coil by opening the upper spigot and the bleed screw.



If the heating coil/cooling coil is not properly vented, air bubbles may form and impair the performance.

7. ▶ Close any vents.
8. ▶ Clean the condensate drip tray and drain.
9. ▶ Set up the droplet eliminator.
10. ▶ Fill the drain trap with water.

**! NOTICE!****Risk of damage to property!**

- When you tighten thread connections, be sure to use a suitable tool (e.g. water pump pliers) to counter the tightening force as otherwise you may inadvertently damage the parts.

11. ▶ Check the flange screw joints and tighten them if necessary.

⇒ The heating coil/cooling coil has been set up.

**6.3.3  Multileaf dampers****Movable parts of multileaf dampers****WARNING!****Crushing hazard from movable parts!**

Closing multileaf dampers may crush your hands and arms.

- Do not reach between the damper blades.
- Prevent access to crush points: Either install dampers on ducts or use fixed guards.
- Before you open an inspection access panel, switch off the air handling unit and secure it against being switched on accidentally.

**Setting up multileaf dampers**

Set the AHU control system in such a way that the fan does not operate against a closed damper.

TROX does not accept liability for damages resulting from incorrect operation. To prevent damage due to pressure surges from fire dampers, pressure relief dampers should be installed.



TROX cannot guarantee leak-free dampers if the actuators are provided and installed by others.

**Powered dampers****Personnel:**

- HVAC technician

**Protective equipment:**

- Industrial safety helmet
- Protective clothing
- Protective gloves
- Safety shoes

- ▶ Adjust the linkage in such a way that the angle of rotation is 90° and the dampers close completely.
- ⇒ Powered multileaf dampers have been set up.

## Coupled dampers (for plate heat exchanger)

### Personnel:

- HVAC technician

### Protective equipment:

- Industrial safety helmet
- Protective clothing
- Protective gloves
- Safety shoes

- ▶ Check that the friction locking of the linkage is correct.
- ▶ Check the direction of rotation direction and ensure that the blades fully open and close.
- ▶ Check that all screw joints and connections are tight.
  - ⇒ The coupled multileaf dampers have been set up.

## 6.3.4 Rotary heat exchanger

### WARNING!

#### Risk of injury from the incorrect handling and operation of fans!

Incorrect handling, e.g. reaching into rotating parts, can lead to serious injuries.

- Never reach into or tamper with the storage mass
- The fan does not stop immediately! Check that no parts are moving before you open an inspection access panel.
- Do not put a damaged or defective rotary heat exchanger into operation.
- Switch off the system before you start working on movable parts of the rotary heat exchanger and secure it against accidentally being switched on again. Wait until all parts have come to a standstill.

### WARNING!

#### Risk of injury caused by hot surfaces!

The storage mass drive motor generates high temperatures. Skin contact with hot surfaces on the drive motor will cause severe skin burns.

- Switch off the air handling unit before working on the rotary heat exchanger and secure the unit against restarting
- After switching off the air handling unit, wait until all surfaces have cooled to the ambient temperature

## Adjusting the rotary heat exchanger

The storage mass of the rotary heat exchanger is factory set. You may have to adjust the storage mass to the actual installation conditions, see  Appendix A 'Adjusting the storage mass' on page 49.

## Setting up the rotary heat exchanger

### Personnel:

- HVAC technician

### Protective equipment:

- Protective clothing
- Hearing protection
- Industrial safety helmet
- Protective gloves
- Safety shoes



Ensure that permitted values for parameters such as temperatures or differential pressure are not exceeded.

- ▶ Check whether the system has been correctly installed.
- ▶ Check the rotary heat exchanger for damage.
- ▶ Check that the rotor moves freely.



Follow the operating instructions from the heat exchanger manufacturer.

- ▶ Check the rotation direction of the rotor and change it on the motor controller, if necessary. Follow the operating instructions from the heat exchanger manufacturer.



If the heat exchanger includes a purge sector, the rotating storage mass passes from the extract air via the purge sector to the supply air.

- ▶ Check that the control module functions correctly.
- ▶ Check the drive belt tension.
- ▶ Setting up the drive equipment,  'Setting up the drive equipment' on page 37.

8. ▶ Check that the seals are tight; readjust them, if necessary.



*If you make any readjustments, ensure that the rotor turns smoothly. The rotor must not grind, not even under operating pressure. The required torque must not be exceeded.*

⇒ The rotary heat exchanger has been set up.

### Setting up the drive equipment

#### Personnel:

- Skilled qualified electrician

#### Protective equipment:

- Protective clothing
- Hearing protection
- Industrial safety helmet
- Protective gloves
- Safety shoes

We recommend that you check the tension of the drive belt regularly during the first 400 hours of operation.

1. ▶ Open the inspection access panel on the indicated corner of the rotor casing.
2. ▶ Check whether the drive belt has sufficient tension; if necessary, shorten the belt ( ↪ *Appendix B 'Drive equipment for rotary heat exchanger' on page 55* ).

### Checking the motor

3. ▶ Ensure that the motor is securely fixed.
- ⇒ The drive equipment has been set up.

### 6.3.5 Droplet eliminator

#### Personnel:

- HVAC technician

#### Protective equipment:

- Protective clothing
- Industrial safety helmet
- Hearing protection
- Protective gloves
- Safety shoes

The droplet eliminator will only reach its full capacity after about four weeks.

1. ▶ Check the installation orientation of the droplet eliminator.
2. ▶ Check the airflow velocity above the droplet eliminator ( $V_{\max}$  4 m/s).

3. ▶ Check the droplet eliminator for contamination and foreign objects; if necessary, clean it with water.
- ⇒ The droplet eliminator has been set up.

### 6.3.6 Plate heat exchanger

#### Setting up the plate heat exchanger

##### Personnel:

- HVAC technician

##### Protective equipment:

- Industrial safety helmet
- Protective clothing
- Protective gloves
- Safety shoes

#### ! NOTICE!

##### Risk of damage to property from extreme pressure drop!

An extreme pressure drop between the supply air and extract air flows can damage the heat exchanger.

- Ensure that the maximum differential pressure (approx. 1000 Pa, depending on unit design) is not exceeded.
- Check differential pressure on pressure monitors according to the specified intervals.

- ▶ Check and, if necessary, clean the plate heat exchanger to remove foreign matter and contamination.

⇒ The plate heat exchanger has been set up.

### 6.3.7 Setting up accessories

#### Personnel:

- Skilled qualified electrician

#### Protective equipment:

- Industrial safety helmet
- Hearing protection
- Protective gloves
- Protective clothing
- Safety shoes

1. ▶ Set the bus address for accessories, see ↪ *Appendix G 'Accessories for X-CUBE compact' on page 117* .
2. ▶ Establish bus communication, see ↪ *Appendix G 'Accessories for X-CUBE compact' on page 117* .

## 6.4 Starting the air handling unit

### 6.4.1 Before you start the AHU

Before you switch on the air handling unit, make sure that the following requirements have been met:

- Has the air handling unit been checked for damage?
- Have the filters been inserted?
- Have all inspection access panels been closed?
- Have all ducts in the AHU been connected?
- Have the AHU and the connected ducts been tested for any leaks?
- Has the interior of the air handling unit been cleaned?
- Have all drain traps been filled with water?
- Does the supply of power and of operating fluids meet all requirements?
- Has all the safety equipment been installed? Does it work properly?
- Have all the electrical connections been made and secured according to the relevant national standards?
- Has the heating coil/cooling coil been correctly connected and filled?
- Has the centrifugal fan been set up?
- Have the multileaf dampers been set up?
- Has the sound attenuator been set up?
- Has the rotary heat exchanger been set up?
- Has the plate heat exchanger been set up?
- Are the environmental conditions for correct use being met?

### 6.4.2 Starting

#### Personnel qualified to start the air handling unit

Only specially trained individuals must start the air handling unit.

Follow the information in the operating manual on how to start the unit.

## 6.5 Configuring the air handling unit

### 6.5.1 X-CUBE controller communication, setup

#### Personnel:

- HVAC technician

#### NOTICE!

##### **Risk of damage to property from incorrect use**

The service interfaces of the touch panel ( Fig. 32 /4) and TCP/IP network ( Fig. 32 /5) are intended for temporary use (e.g. service).

When not in use, protect the service interfaces from the weather by fitting caps.

If the device is used for a long period of time, it may be damaged by moisture, especially if it is installed outdoors.

The permanent and professional installation of the bus connecting cables is carried out at the inputs and outputs of the control master using the existing cable penetrations as cable glands; see  'Cable entry points on the X-CUBE compact' on page 32 .



*If any accessories have been installed be sure to follow the installation and commissioning instructions for those accessories before you start configuring the unit.*

You can assign the X-CUBE controller a static IP address; as an alternative, the controller can receive a dynamic IP address (DHCP) via the network.



#### **Default IP address:**

192.168.2.1

If you intend to connect the air handling unit to a personal computer, you need to set the static IP address on the touch panel. If you intend to integrate the air handling unit with a network, you need to obtain the IP address dynamically (DHCP) from the network.

1. ▶ Start the air handling unit.
2. ▶ On the touch panel, select 'Menu → Settings → Language' .

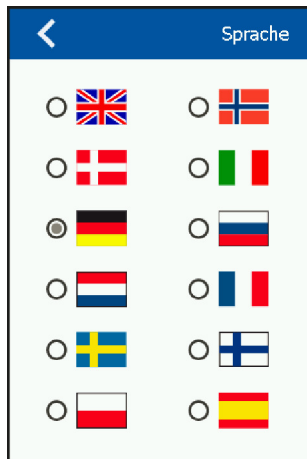

Fig. 34: 'Language' window

3. ▶ Select a language.
4. ▶ On the touch panel, select 'Menu → Communication'.

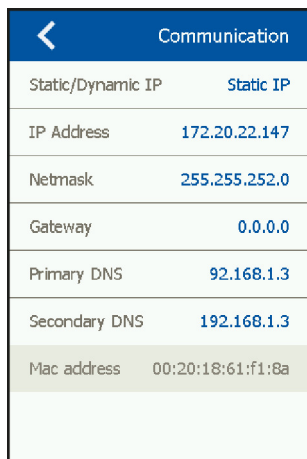

Fig. 35: 'Communication' window

5. ▶ Select 'Static IP/DHCP'.

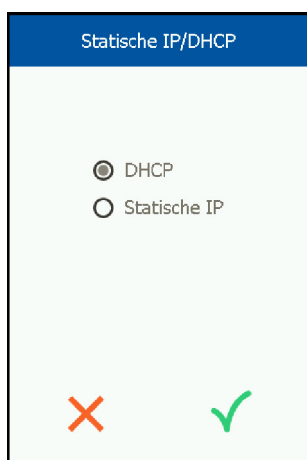

Fig. 36: DHCP or static IP

6. ▶ Set the static IP address or set dynamic assignment of the IP address (DHCP), then confirm your selection with ✓.

⇒ Communication for the X-CUBE controller has been set up.

### 6.5.2 Setting up network communication

#### Personnel:

- HVAC technician

If you want to use a PC to communicate with the air handling unit you have to set up the network connection. The following steps apply to a Windows PC.

1. ▶ On the desktop, select 'Start → Control Panel → Network and Internet → Network and Sharing Center'.

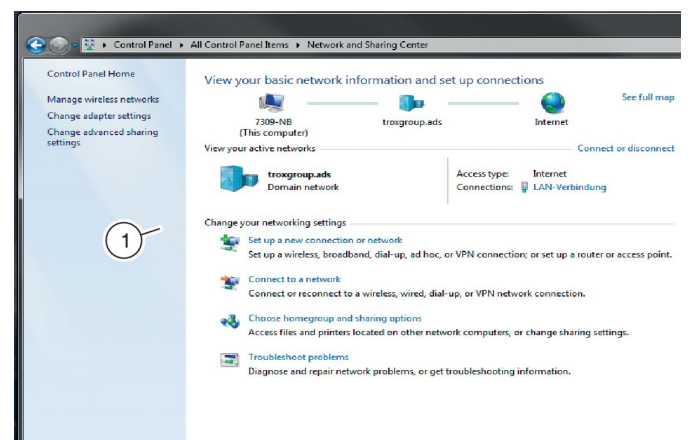

Fig. 37: Setting up a new connection or network

2. ▶ Select 'Set up a new connection or network' ( Fig. 37 /1).

⇒ The 'Set up a connection or network' window opens.

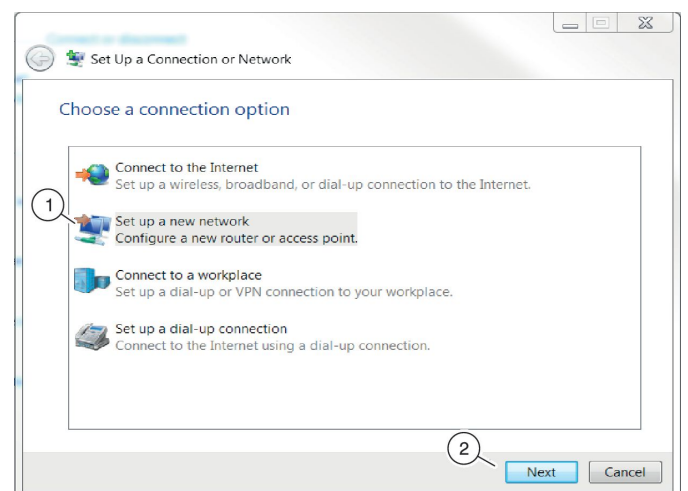

Fig. 38: Setting up a new network

3. ▶ Select 'Set up a new network' ( Fig. 38 /1), then click 'Next' ( Fig. 38 /2).

⇒ The software searches for an access point.

4. ▶ Select the air handling unit.

⇒ The 'Local Area Connection Status' window opens.

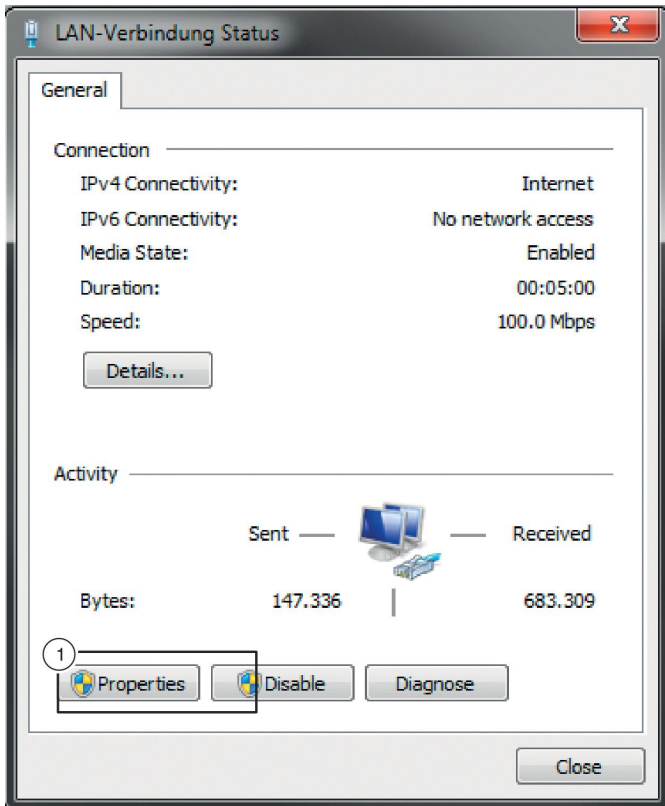

Fig. 39: LAN connection status

5. ▶ Select 'Properties' ( Fig. 39 /1).

⇒ The 'Local Area Connection Properties' window opens.

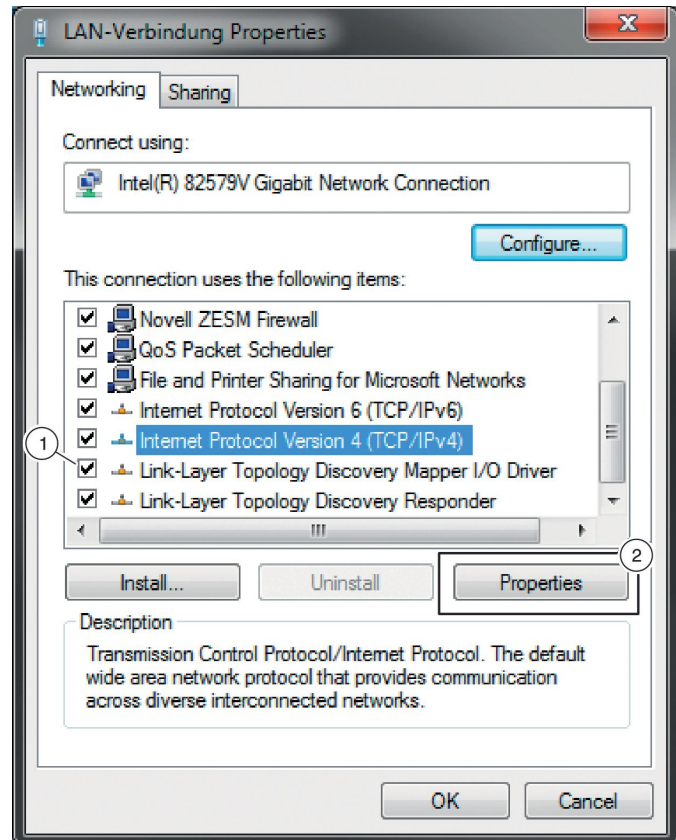

Fig. 40: LAN connection properties

6. ▶ Select 'Internet Protocol Version 4 (TCP/IPv4)' ( Fig. 40 /1), then click on the 'Properties' ( Fig. 40 /2) button.

⇒ The 'Internet Protocol Version 4 (TCP/IPv4) Properties' window opens.



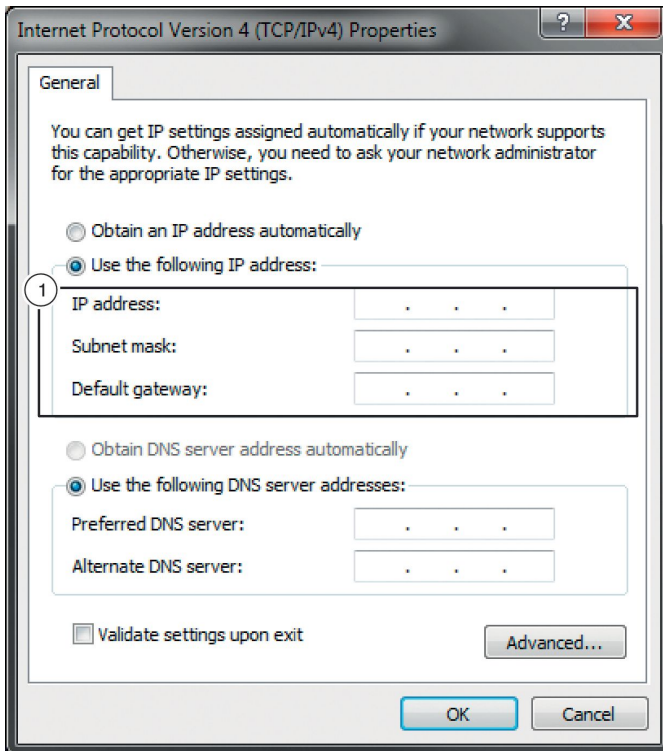



Fig. 41: Internet protocol properties

7. ▶ Select the 'Use the following IP address:' ( Fig. 40 /1) option, enter the IP address, subnet mask and default gateway and confirm with 'OK'.
  - ⇒ The connection has been set up and the air handling unit can be operated using the web browser.

  
 Restart the PC if necessary.

## 6.6 Logging in to the web server

### Personnel:

- HVAC technician

There are three login levels to access the web server. Each level has different access rights to use operating, maintenance or configuration functions.

Level	User name	Pass-word	Function
User	USER	0001	Setpoints
Installer	INSTALLE	0022	Setpoints and control settings

Level	User name	Pass-word	Function
Service	SERVICE	0333	Service parameters

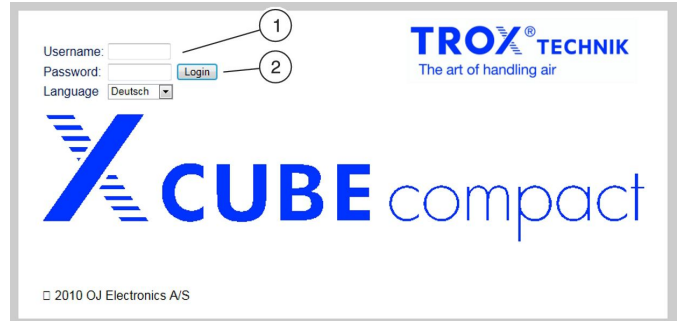

Fig. 42: Logging in to the web server

1. ▶ Enter your user name ( Fig. 42 /1).
2. ▶ Enter your password.
3. ▶ Select 'Login' ( Fig. 42 /2).
  - ⇒ You are now logged in to the web server.

## 7 Disassembly and disposal

### 7.1 Safety notes regarding disassembly and disposal

#### Incorrect disassembly

 **DANGER!**

**Risk to life from incorrect assembly and disassembly!**

Incorrect assembly or disassembly can result in risks to life and limb and in environmental hazards.

- Before you start disassembly, professionally disconnect all electrical cables.
  - Only a skilled qualified electrician must disconnect the power supply.
  - Ensure that no voltage is present.
- Before you start disassembly, correctly drain all operating fluids.
  - Disconnect operating fluid pipes and hoses.
  - Ensure that operating fluids are disposed of correctly.
- If you have any questions regarding disassembly, refer to the assembly instructions in this manual.  
Pay attention to the component manufacturers' documentation.
- Only trained specialist personnel must remove any components.
- If necessary, use additional personal protective equipment for outdoor installations, e.g. a safety harness.

#### Improper transport equipment

 **WARNING!**

**Risk to life from using improper transport equipment!**

If packages are lifted without adequate transport equipment and if they are not properly secured, they may fall off and lead to fatal injuries.

- Move components only in the position in which they are to be installed.
- Stand clear of suspended loads.
- Do not move additional loads on top of a package.
- Use only the intended lashing points.
- Make sure that no load is imposed on pipes, ducts or cables.
- Use only approved lifting gear and slings that are suitable and sufficient for the load to be carried.
- Do not tie ropes and chains or make knots or place them on sharp edges.
- Use lifting equipment only to lift packages or units, not to push or pull them.
- Ensure that ropes, belts and chains do not twist.
- Ensure that transport equipment has been correctly assembled, fastened and secured before you use it to lift anything.
- Secure all doors, dampers and panels.
- Move packages without any jerky movements and put them down when you leave your workplace.
- Lifting eyes are designed for one-time use only and not for permanently suspending loads.
- Transport tubes are designed for one-time use only and not for permanently suspending loads.
- Note the information on transport  
*↪ Chapter 3.3 'Moving packages' on page 11*

#### Unbalanced loads and centre of gravity

 **WARNING!**

**Risk of injury from falling or toppling loads!**

Loads may be unbalanced, i.e. the centre of gravity may not be obvious. If the load is not properly attached to the lifting equipment, it may topple and fall. Falling or toppling loads can cause serious injuries.

- When you use a crane to move loads, ensure that the centre of gravity of the load is directly beneath the crane hook.
- Lift any load carefully and keep an eye on it to see whether it will stay in place. If required, change the lashing point(s).

### Sharp edges, sharp corners and thin sheet metal parts

#### CAUTION!

#### Danger of injury from sharp edges, sharp corners and thin sheet metal parts!

Sharp edges, sharp corners and thin sheet metal parts of the heat exchanger or of the cooling or heating coil may cause cuts or grazes.

- Be careful when working on these components.
- Wear protective gloves, safety shoes and a hard hat.

#### ENVIRONMENT!

#### Risk of harm to the environment due to incorrect disposal of goods and packaging!

Incorrect disposal can harm the environment.

- Have electronic waste, electronic components and operating fluids (refrigerant, compressor oil, lubricants etc.) disposed of by an approved specialist disposal company.

## 7.2 Disassembly

### Personnel:

- HVAC technician
- Skilled qualified electrician

### Protective equipment:

- Industrial safety helmet
- Protective clothing
- Hearing protection
- Protective gloves
- Safety shoes

1. ▶ Disconnect electrical cables.  
Ensure that no voltage is present.
2. ▶ Remove all operating fluids.  
Properly dispose of all operating fluids.
3. ▶ Disconnect operating fluid pipes and hoses.
4. ▶ Open all module connectors and base frame connectors.
5. ▶ Remove the individual unit components.  
Use suitable transport equipment to move unit components away from the site.

## 7.3 Disposal

If no return or disposal agreement is in place, any disassembled components should be disposed of by an approved specialist disposal company.

Components that are no longer required should be recycled:

- Scrap the metals.
- Take plastic parts to be recycled.
- Dispose of other components and waste in a suitable manner, i.e. depending on their material properties.

### Electrical and electronic components

Electrical and electronic components can contain materials and substances that are hazardous to health and the environment and which must not get into household and commercial waste.

As electrical and electronic components may also contain recyclables (e.g. precious metals), they must be provided for recycling or disposal by a specialist disposal company.

### Chemicals

Chemicals (solvents, cleaning agents, operating fluids, etc.) affect the air, soil, water, and human health in various ways. In some cases, valuable substances can be extracted from them.

Chemicals must therefore not get into the air, soil, sewerage system, surface water or groundwater.

Commission an approved specialist disposal company to recover or dispose of chemicals.

## 8 FAQ

No.	Question	Answer
1	How to connect accessory modules (e.g. heating coil, cooling coil, digital control panel) to the X-CUBE control system?	<p>For information on how to commission accessory modules and for the relevant system diagrams see the 'Installation and commissioning manual – Accessories for X-CUBE compact units', chapter 5, Connection diagrams.</p> <p>( ↪ <i>Appendix G 'Accessories for X-CUBE compact' on page 117</i> )</p>
2	How to establish bus communication between an accessory module (e.g. heating coil, heating coil/cooling coil module) and the air handling unit?	<p>For information on how to commission accessory modules see the 'Installation and commissioning manual – Accessories for X-CUBE compact', chapter 3, Establishing bus communication, and chapter 2, Setting bus addresses for accessories.</p>
3	Where do I find technical data for the air handling unit, e.g. dimensions, weight, output, or whether the unit casing can be divided?	<p>For the complete technical data see the 'Operating manual – X-CUBE compact air handling units', chapter 10, Technical data.</p> <p>( ↪ <i>X-CUBE compact operating manual</i> )</p>
4	Where do I connect the PT1000 temperature sensors to the X-CUBE control system?	<p>The PT1000 room temperature sensor is to be connected to terminals X2/13/14, and the PT1000 outdoor air temperature sensor is to be connected to terminals X2/15/16 of the X-CUBE Control master. See the circuit diagrams in the appendix.</p> <ul style="list-style-type: none"> <li>▪ ( ↪ <i>Appendix C 'Circuit diagram, controls tray, 230 V AC-PWT' on page 61</i> )</li> <li>▪ ( ↪ <i>Appendix D 'Circuit diagram, controls tray, 230 V AC-RWT' on page 75</i> )</li> <li>▪ ( ↪ <i>Appendix E 'Circuit diagram, controls tray, 400 V AC-PWT' on page 89</i> )</li> <li>▪ ( ↪ <i>Appendix F 'Circuit diagram, controls tray, 400 V AC-RWT' on page 103</i> )</li> </ul>
5	Where do I connect the analogue XCC-CD-RA control panel and the digital XCC-CD-RD control panel to the X-CUBE control system?	<p>For information on how to connect the control panels see the connection diagrams in the 'Installation and commissioning manual – Accessories for X-CUBE compact units', chapter 5.1, XCC-CD-RA, and chapter 5.2, XCC-CD-RD. For information on cables and settings see the connection diagrams. The maximum cable length is 30 m.</p> <p>( ↪ <i>Appendix G 'Accessories for X-CUBE compact' on page 117</i> )</p>
6	How do I find out whether the digital room control panel XCC-CD-RD has been correctly connected to the X-CUBE control system, and how is the communication to the room control panel being monitored?	<p>The digital control panel is to be connected according to the connection diagram in the 'Installation and commissioning manual – Accessories for X-CUBE compact units', chapter 5.2, XCC-CD-RD.</p> <p>( ↪ <i>Appendix G 'Accessories for X-CUBE compact' on page 117</i> )</p> <p>If the unit has been correctly connected, the time and date are displayed on the digital control panel. If date and time are not displayed, check whether the RJ12 Modbus cable of the control panel has been correctly connected to port A (RJ12). If the RJ12 Modbus cable has been connected to port B or C, connect it to the correct port A.</p>

No.	Question	Answer
7	Where and how do I connect the fire damper to the X-CUBE control system? How many fire dampers can I connect to X-CUBE control?	<p>Connect the fire damper to terminals X2/1/2 on the X-CUBE Control master (NC contact). You can connect up to 300 fire dampers (in series) with one NC contact. For information on how to connect fire dampers see the electrical circuit diagram.</p> <ul style="list-style-type: none"> <li>■ ( ↗ Appendix C 'Circuit diagram, controls tray, 230 V AC-PWT' on page 61 )</li> <li>■ ( ↗ Appendix D 'Circuit diagram, controls tray, 230 V AC-RWT' on page 75 )</li> <li>■ ( ↗ Appendix E 'Circuit diagram, controls tray, 400 V AC-PWT' on page 89 )</li> <li>■ ( ↗ Appendix F 'Circuit diagram, controls tray, 400 V AC-RWT' on page 103 )</li> </ul> <p>When one or more fire dampers are released, the system stops operating (A alarm). The dampers will not automatically reopen after they have been released. You have to manually acknowledge (reset) the alarm on the touch panel.</p>
8	How many motorised fire dampers can I connect to the compact unit?	You cannot connect any motorised fire dampers to the air handling unit. For motorised fire dampers we recommend you to use a TNC-Easy module. A TNC-Easy module allows for connecting up to 12 motorised fire dampers. For more information contact your TROX sales representative.
9	How do I attach an accessory module directly to the air handling unit, and how do I attach it if a staggered arrangement is required?	<p>The 'Transport and installation manual – X-CUBE compact air handling unit', chapter 'Installing accessories', contains information on how to attach an accessory module to the air handling unit.</p> <p>See ( ↗ Chapter 4.5.4 'Installing accessories' on page 24 ).</p> <p>In case there is not enough space to attach an accessory module directly to the air handling unit:</p> <p>See ( ↗ Chapter 4.5.4 'Installing accessories' on page 24 ).</p>
10	Can I detach the plate heat exchanger so that it is easier to bring it into the installation room?	<p>The correct disassembly of the plate heat exchanger is described in the 'Operating manual – X-CUBE compact air handling unit'.</p> <p>See ( ↗ X-CUBE compact operating manual ).</p>
11	Do I need a separate supply voltage for an accessory module and for the controls modules (XCC-CB-1 or XCC-CB-2)?	Yes, you need 230 V AC supply voltage.
12	What does the error message 'Contact is sticking' mean and how do I solve the problem?	This error message only appears when an accessory module is used. If an accessory module with a controls module (XCC-CB-1 or XCC-CB-2) has been ordered, the extension module is factory set to address 8. You then have to check the bus address on the controls module and to enter the correct settings for bus communication. See chapters 2 and 3 of the 'Installation and commissioning manual – Accessories for X-CUBE compact units' ( ↗ Appendix G 'Accessories for X-CUBE compact' on page 117 ).
13	Which communication interfaces are available on the air handling unit?	TCP/IP BACnet, Modbus and Modbus RTU.

## 9 Index

### A

Adjusting multileaf dampers.....	35
AHU	
Electrical connection.....	31
Removing.....	19
AHU casing units	
Assembling AHU casing units for outdoor installation.....	22
Fitting base frame plugs.....	22
Individual assembly.....	22
Installing ducts.....	24
Setup.....	20
AHU components	
Seals, checking.....	20
Air handling unit	
Commissioning.....	33
Assembly	
Accessory module.....	24
AHU casing units for outdoor installation.....	22
Assembling individual AHU casing units.....	22
Base frame plugs.....	22
Ducts.....	24
Noise insulating connector.....	24
Roof for accessory modules.....	26

### C

Components, X-CUBE compact.....	6
Condensate drain.....	29
Cooling coil	
Commissioning.....	34
Installing.....	30
Copyright.....	3

### D

Defects liability.....	3
Delivery of the air handling unit.....	10
Disassembly and disposal.....	43
Drain trap, connecting.....	29
Droplet eliminator.....	37

### E

Electrical connection.....	31
Environmental protection	
Chemicals.....	43
Electrical and electronic components.....	43

### F

Filters, inserting.....	34
Fitting base frame plugs.....	22

### H

Heating coil	
Commissioning.....	34
Installing.....	30
Height of drain trap.....	28
Hotline.....	3

### I

Improper transport equipment.....	11
Initial commissioning.....	33
Droplet eliminator.....	37
Filters.....	34
Heating coil/cooling coil.....	34
Multileaf dampers.....	35
Plate heat exchanger.....	37
Rotary heat exchanger.....	36
Starting.....	38

### Installation

Condensate drain.....	29
Connecting the heating coil/cooling coil.....	30
Connection to the central BMS.....	31
Drain trap, connecting.....	29
Height of drain trap.....	28
Network connection.....	31
Installation location, requirements	
Installation room.....	18
Installation room, foundation.....	18
Outdoor installation, foundation.....	18

Installing ducts.....	24
IP address.....	38

### L

Limitation of liability.....	3
Logging in to the web server.....	41

### N

Noise insulation.....	19
-----------------------	----

### O

Other applicable documentation.....	3
-------------------------------------	---

### P

Packages	
Storage.....	15
Transport.....	12, 13
Unpacking.....	15
Packaging, disposal.....	15
Parts, X-CUBE compact.....	6
Personnel.....	8
Plate heat exchanger.....	37

### Q

Qualification.....	8
--------------------	---

<b>R</b>			
Removal			
Noise insulating connector.....	23		
Requirements			
Assembly.....	21		
Initial commissioning.....	33		
Installation.....	27		
Starting.....	38		
Requirements for the installation location			
Installation room.....	17		
Rotary heat exchanger.....	36		
Drive equipment, setup.....	37		
<b>S</b>			
Service.....	3		
Setting up network communication.....	39		
Setup and assembly.....	17		
Starting.....	38		
Storage.....	15		
Symbols.....	4		
On the packaging.....	10		
Transport.....	10		
		System owner.....	8
		System owner's obligations.....	8
		<b>T</b>	
		Technical Service.....	3
		Transport	
		Crane and lifting eyes/eye nuts.....	14
		Crane and transport tubes.....	13
		Delivery.....	10
		Delivery check.....	10
		Forklift or pallet truck.....	12
		Units for indoor installation.....	14
		Transport damage.....	10
		<b>U</b>	
		Unpacking.....	15
		<b>V</b>	
		Vibration, preventing.....	19
		<b>W</b>	
		Warranty claims.....	3
		<b>X</b>	
		X-CUBE controller communication, setup.....	38

## Appendix



## **A Adjusting the storage mass**

# **Montageanleitung Mounting Instructions**

Ausrichtung der Speichermasse  
Adjustment of storage mass

Um die Speichermasse auf der Antriebswelle zu justieren, müssen auf beiden Seiten des Rotors die Staubdeckel entfernt werden.

To reposition the the matrix on the drive shaft, on both sides of the rotor the hub caps have to be removed.

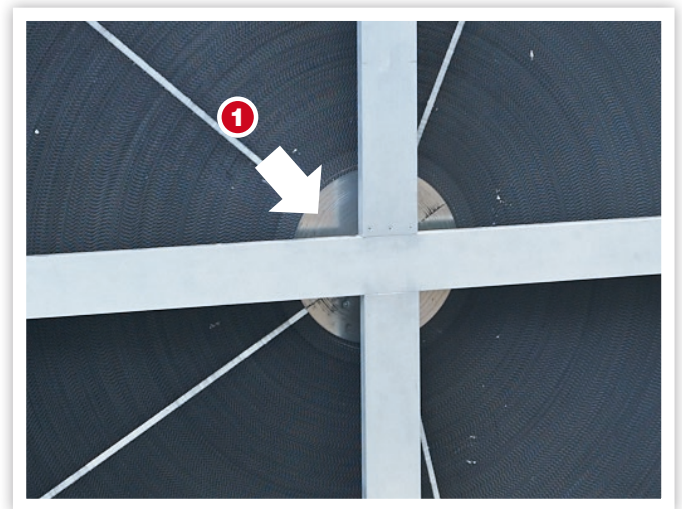
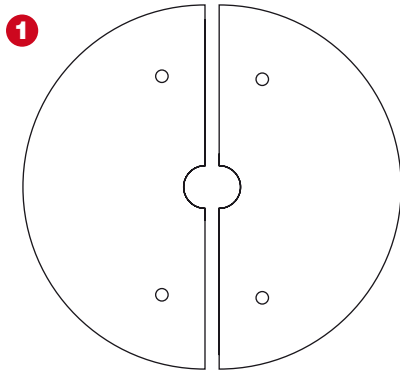

Der Staubdeckel besteht aus zwei Teilen und ist mit je 2 Schrauben befestigt, welche mit einem Imbusschlüssel (Größe 2,5) zu lösen sind.

The hub cap consists of two parts and is fixed with 2 allen screws per part which need a 2.5 mm allen key.

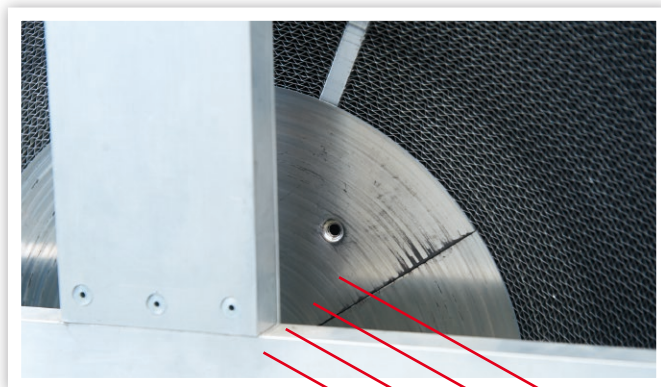
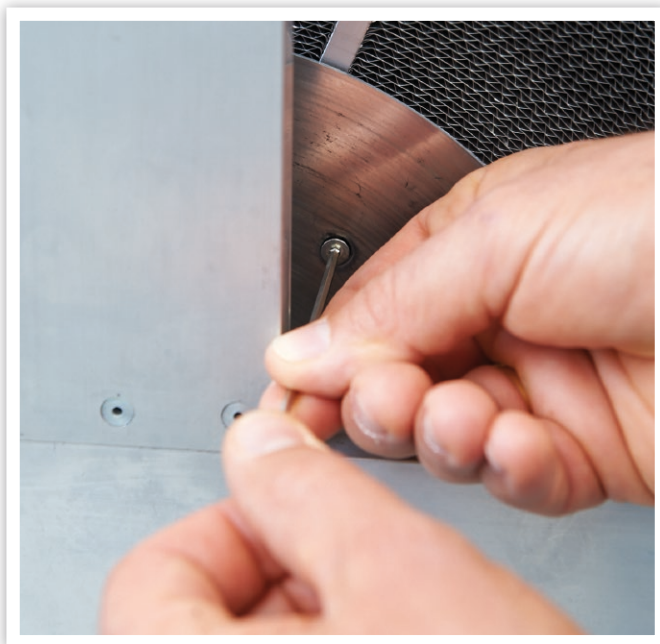

Dazu alle 4 Schrauben lösen.

For this, loosen all 4 screws.

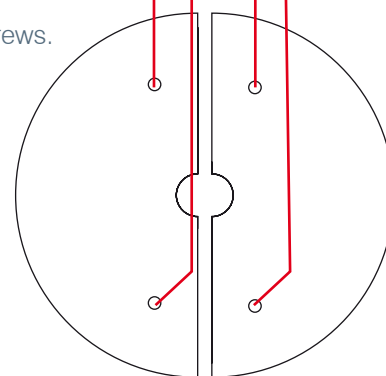

Die beiden Staudeckelteile entfernen. Der Lagerbereich liegt nun offen. Dieser Vorgang ist auf der gegenüberliegenden Seite des Rotors zu wiederholen.

Remove both parts of the hub cap. The bearings are now accessible. Repeat this procedure on the opposite side of the rotor.

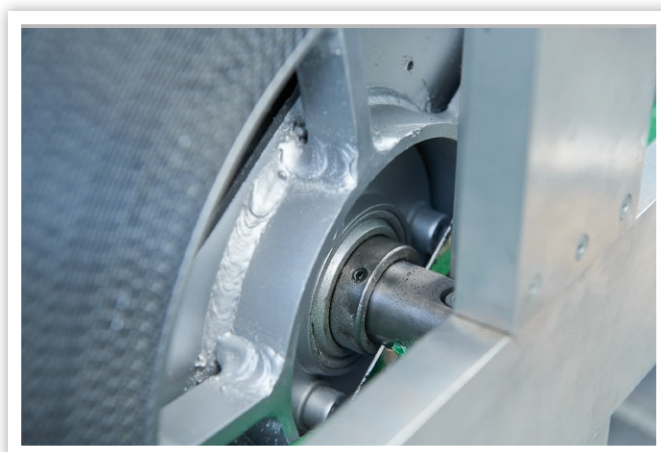

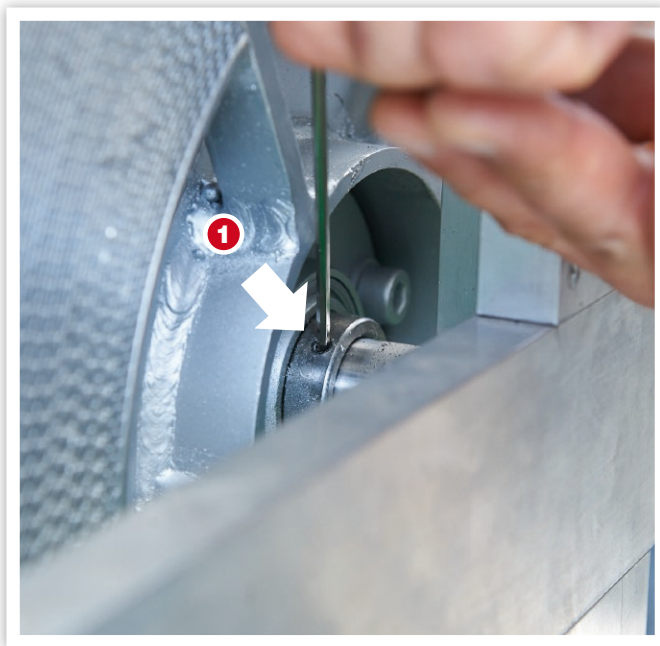

Beide Mardenschrauben (1) und (2) am Lager lösen. Dieses auch auf der gegenüberliegenden Seite des Rotors wiederholen.

Loosen both set screws, (1) and (2). Repeat this procedure on the opposite side of the rotor.

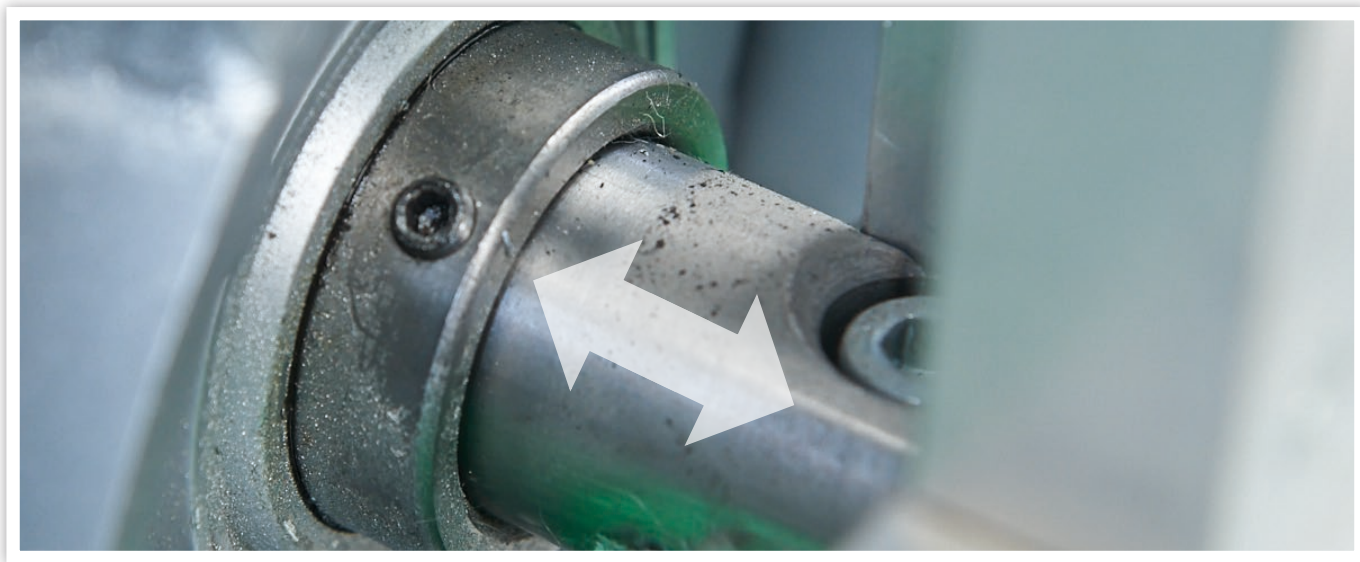
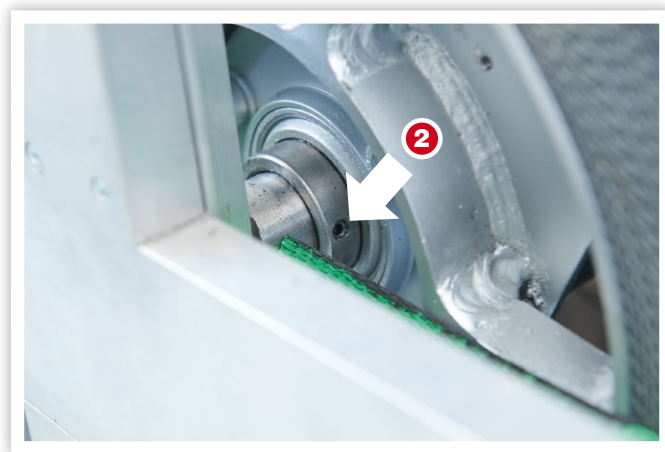

Nun kann die Speichermasse auf der Welle entsprechend justiert werden. Lässt die Speichermasse sich nicht bewegen, kann diese vorsichtig mit leichten Schlägen gelöst werden. Verwenden Sie dazu ein Holzkant. Nach erfolgreicher Justierung sind auf beiden Seiten des Rotors die Lagerschrauben anzuziehen und die Staubdeckel wieder zu anbringen.

Now the matrix can be moved on the shaft. If not, the matrix may be carefully released with light blows. Use a square timber. After successful repositioning, re-apply bearing screws and hub cap.

---

### **Klingenburg GmbH**

Boystraße 115

45968 Gladbeck

GERMANY

Tel. +49 (0) 20 43 / 96 36 - 0

Fax +49 (0) 20 43 / 7 23 62

e-mail: [klingenburg@klingenburg.de](mailto:klingenburg@klingenburg.de)

web: [www.klingenburg.de](http://www.klingenburg.de)

### **Klingenburg International sp. z o.o.**

ul. Metalowców 5

58-100 Swidnica

POLAND

Tel.: +48 (0) 74 / 851 54 00

Fax: +48 (0) 74 / 851 54 01

e-mail: [klingenburg@klingenburg.pl](mailto:klingenburg@klingenburg.pl)

web: [www.klingenburg.pl](http://www.klingenburg.pl)

### **Klingenburg USA, LLC**

503 Old Thomasville Road

High Point, NC 27260

USA

Tel.: +1 -336-884-5050

Fax: +1 -336-884-5058

e-mail: [info@klingenburg-usa.com](mailto:info@klingenburg-usa.com)

web: [www.klingenburg-usa.com](http://www.klingenburg-usa.com)

### **Klingenburg Shanghai**

Representative Office

Room 24/P Jinsui Mansion

No. 379 Pudong South Road

Shanghai

P.R. CHINA

Tel.: +86 (0) 21 / 68 86 92 51

Fax: +86 (0) 21 / 68 86 99 31

e-mail: [klingenburg@klingenburg.cn](mailto:klingenburg@klingenburg.cn)

web: [www.klingenburg.cn](http://www.klingenburg.cn)

**B Drive equipment for rotary heat exchanger**

# Assembly instructions

**Belt Drive for Rotary Heat Exchangers**  
Round Belting



## Preparation

Length of the drive belt:

Circumference of the storage mass + 20 mm:

**(diameter of the storage mass x 3.14) + 20 mm**

Fix the loose round belt to the circumference of the storage mass.

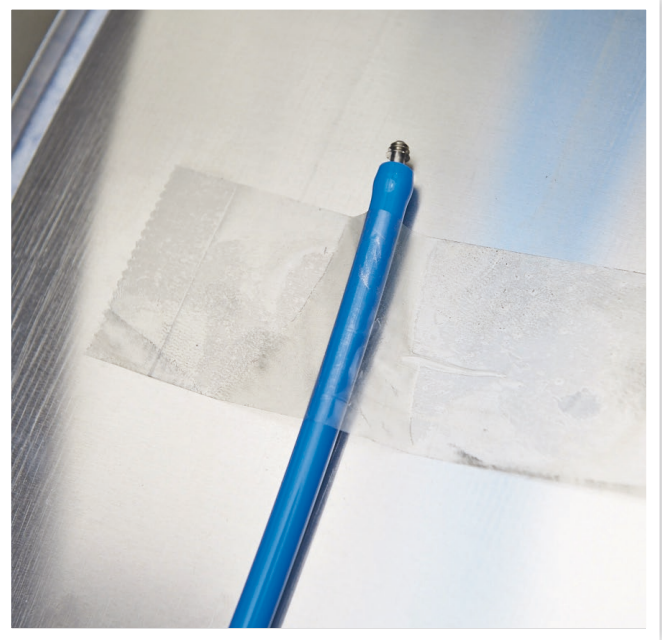

Turn the storage mass by hand, thus tightening the drive belt.



Connect the ends of the round belt to the plug-in connector.



Completely sealed drive belt.

Check the tension of the drive belt.

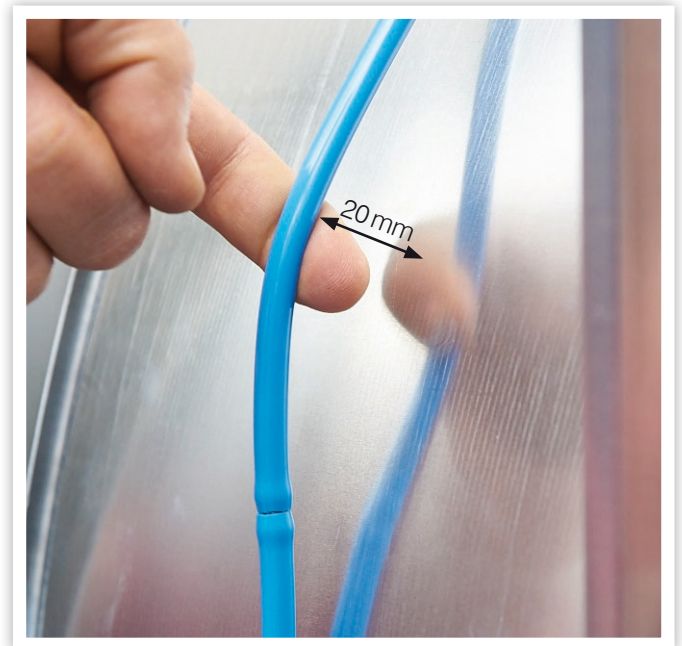

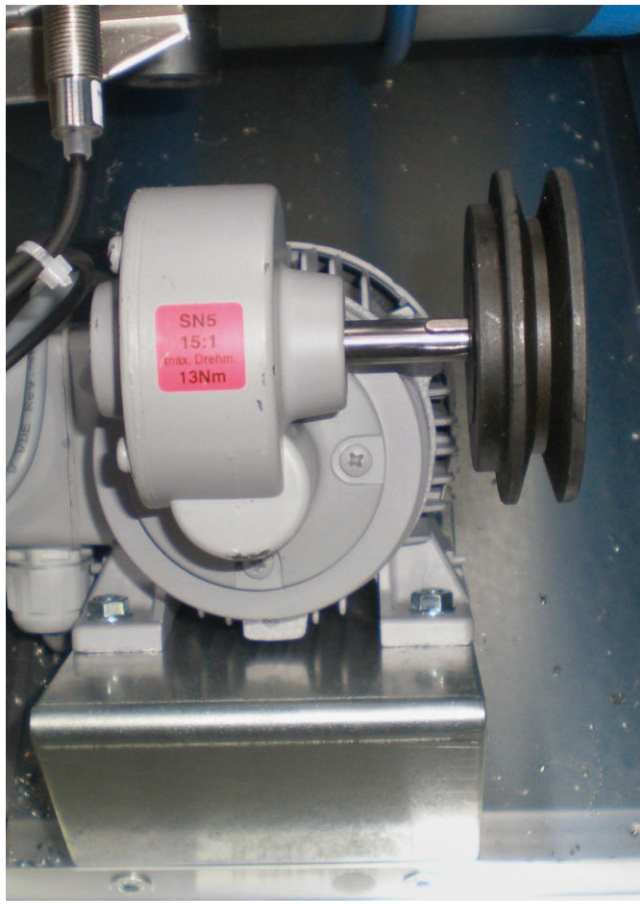

Connect the motor belt to the motor's belt pulley..

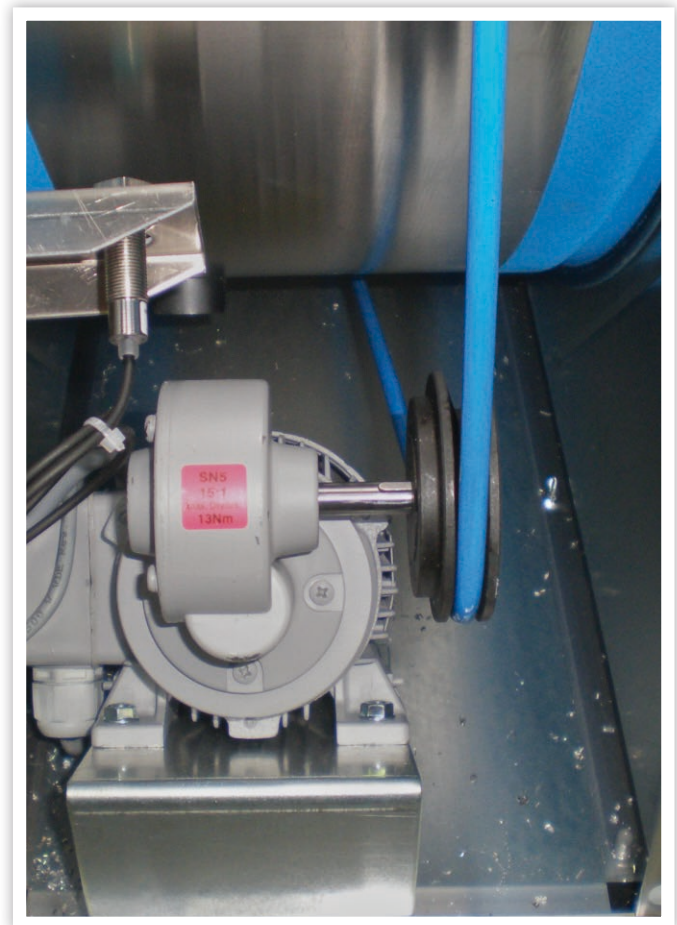

The tension of the drive belt must be checked after 400 operating hours (see page 3) and, if necessary, readjusted by shortening.



**Note**

A large, light blue rounded rectangular area containing horizontal white lines for writing notes.

**C      Circuit diagram, controls tray, 230 V AC-PWT**



# TROX GmbH

Heinrich-Trox-Platz  
 47504 Neukirchen-Vluyn  
 E-Mail: trox@trox.de, Internet: www.trox.de

Customer :  
 Type : drawer MSR 230VAC X-Cube C/R (L)/P/1230/1800  
 Project name :  
 Article no. : A35139

Manufacturer (Firm) : TROX  
 File name (\EPLAN4\P) : 12-1003-A  
 Project name :  
 :  
 :  
 :  
 :

Index. 00-1/17

Created on : 10.10.12 by : JK Highest Page No. : 9  
 Processed on : 10.02.17 by : JK No. of pages : 13

Changes	Date	Name	Norm	5.7.0	Tested	10.02.17	Editor	JK	Date	08.08.16	drawer	MSR 230AC	Original	Sub. f.	Sub. b.	X-Cube C/R (L)/P/1230/1800	cover page	draw. -No. : 12-1003A	=	+	P. 0.1	9 P.



600

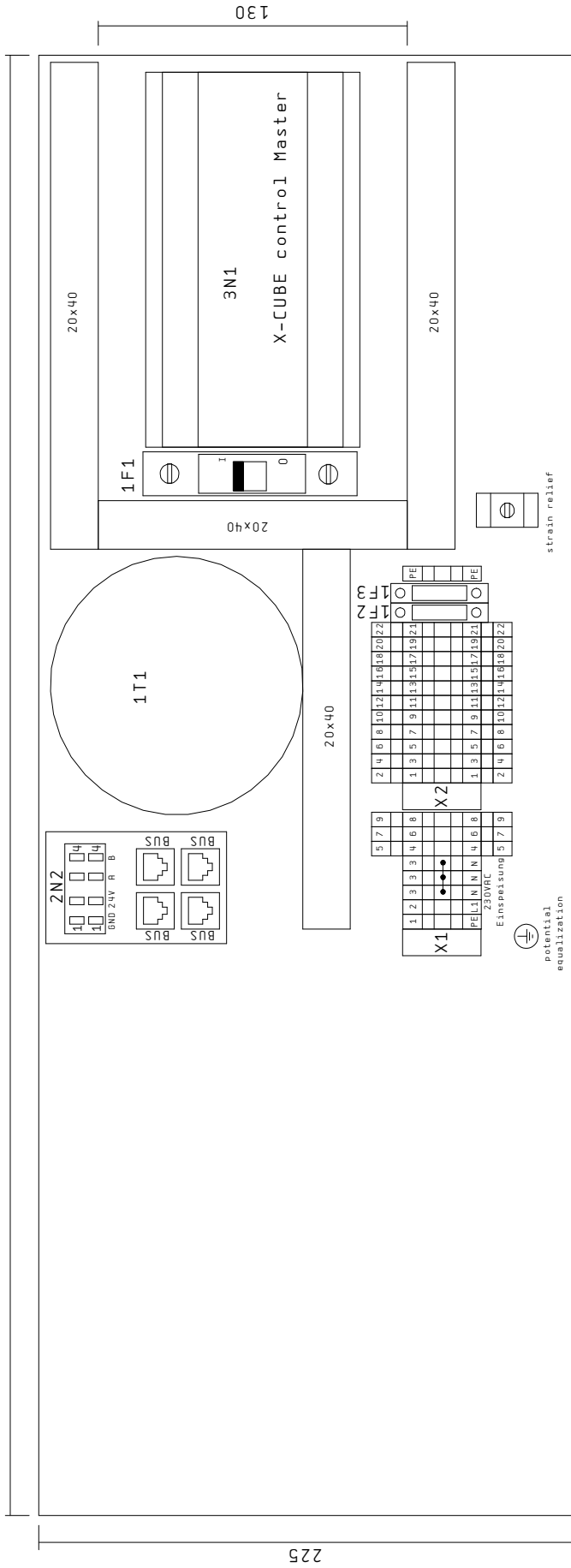

Changes	Date	Name	Norm	5.7.0	Tested	10.02.17	Editor	JK	Date	08.08.16	drawer	MSR 230AC	Original	Sub. f.	Sub. b.	X-Cube C/R (L)/P/1230/1800	drawer design	draw. - No. : 12-1003A	R35139	P. 0.3	9 P.
---------	------	------	------	-------	--------	----------	--------	----	------	----------	--------	-----------	----------	---------	---------	-------------------------------	---------------	------------------------	--------	--------	------







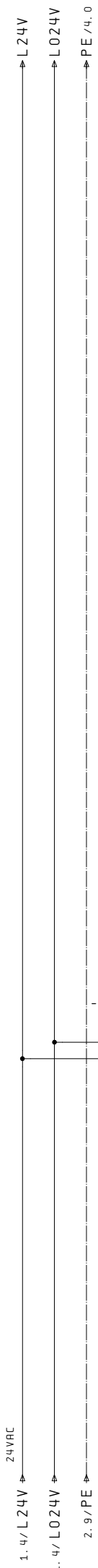

**!!attention!**  
 it consists danger from  
 irreparable defect to X CUBE control Master!  
 never connect voltage supply 24 Volt AC  
 from X CUBE control master  
 with digital in and analog input and output.

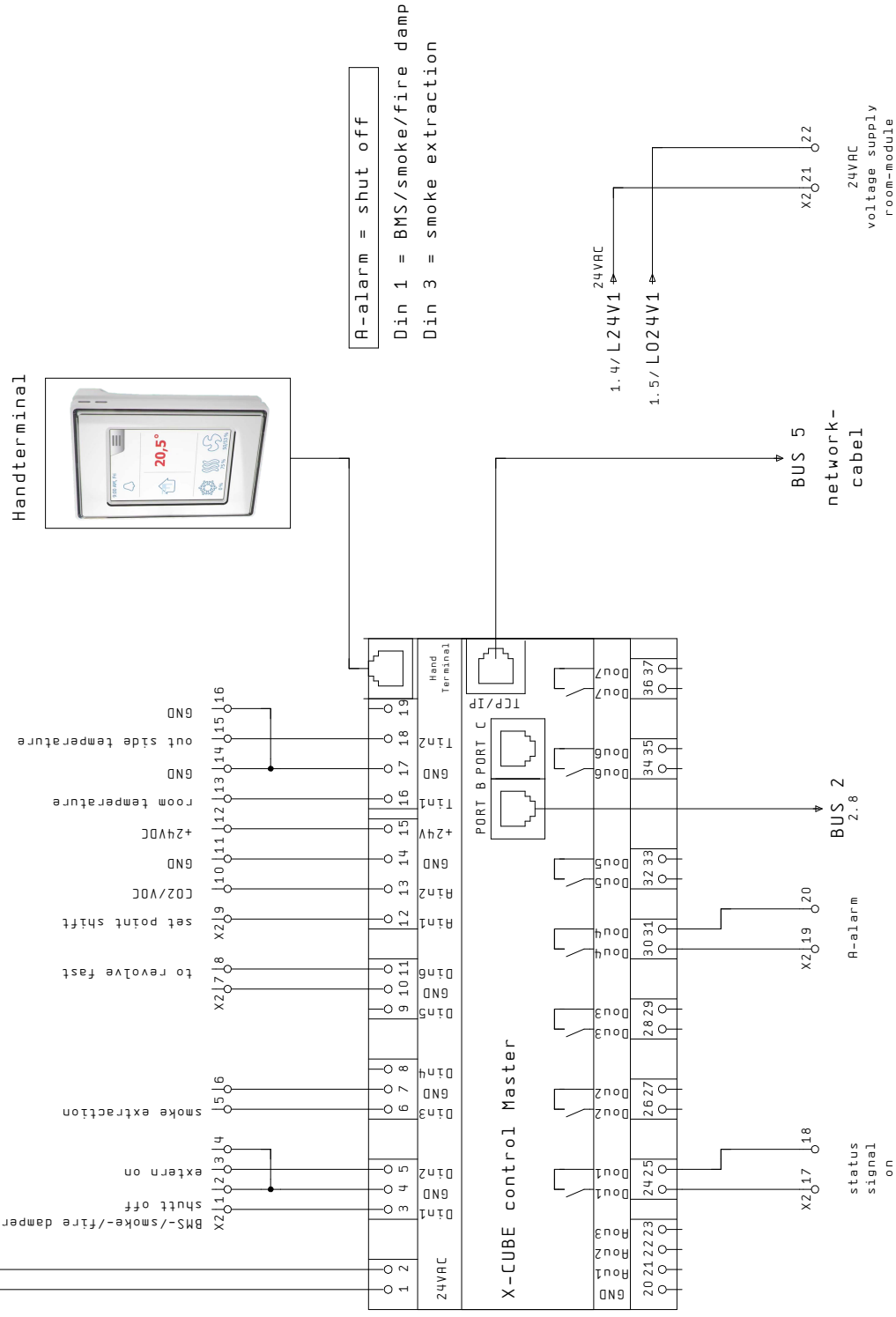
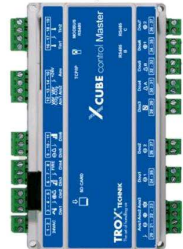

A-alarm = shut off  
 Din 1 = BMS/smoke/fire damper  
 Din 3 = smoke extraction

changes	Date	Name	Norm	5.7.0	Original	Editor	JK	08.08.16	drawer	MSR 230AC	X-Cube C/R	X-Cube control Master	draw. -No.: 12-1003A	+	P. 3	9 P.
	Tested										(L)/P/1230/1800		R35139	=		

# example sample-wiring

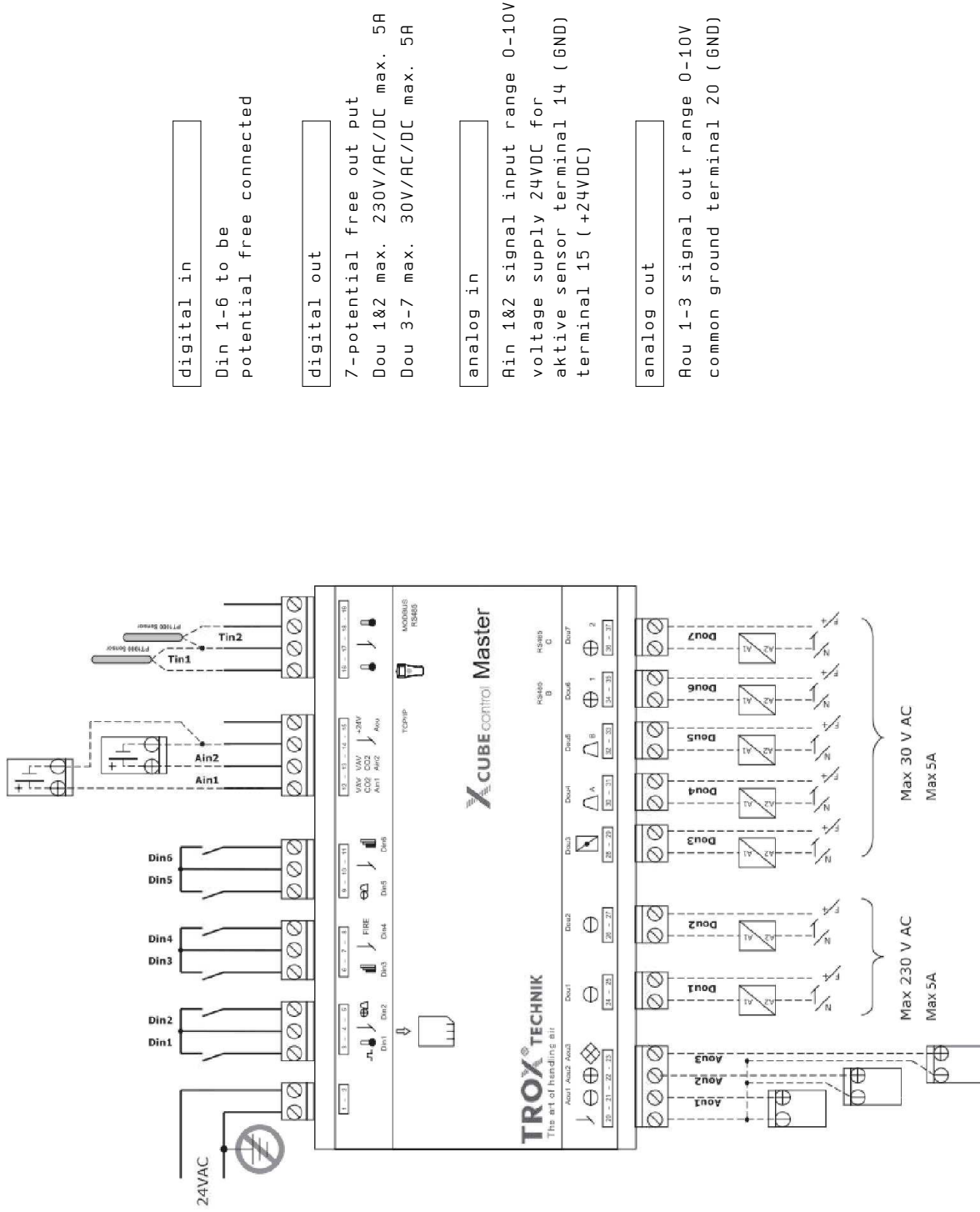

digital in

Din 1-6 to be potential free connected

digital out

7-potential free out put  
Dou 1&2 max. 230V/AC/DC max. 5A  
Dou 3-7 max. 30V/AC/DC max. 5A

analog in

Ain 1&2 signal input range 0-10V  
voltage supply 24VDC for active sensor terminal 14 (GND)  
terminal 15 (+24VDC)

analog out

Rou 1-3 signal out range 0-10V  
common ground terminal 20 (GND)

changes	Date	Name	Norm	5.7.0	Tested	10.02.17	Editor	JK	08.08.16	drawer	MSR 230AC	Original	Sub. f.	Sub. b.	X-Cube compact	X-Cube C/R (L)/P/1230/1800	X-Cube control Master example sample-wiring	draw. -No. : 12-1003A	R35139	P. 3.1	9 P.
---------	------	------	------	-------	--------	----------	--------	----	----------	--------	-----------	----------	---------	---------	----------------	----------------------------	---	-----------------------	--------	--------	------

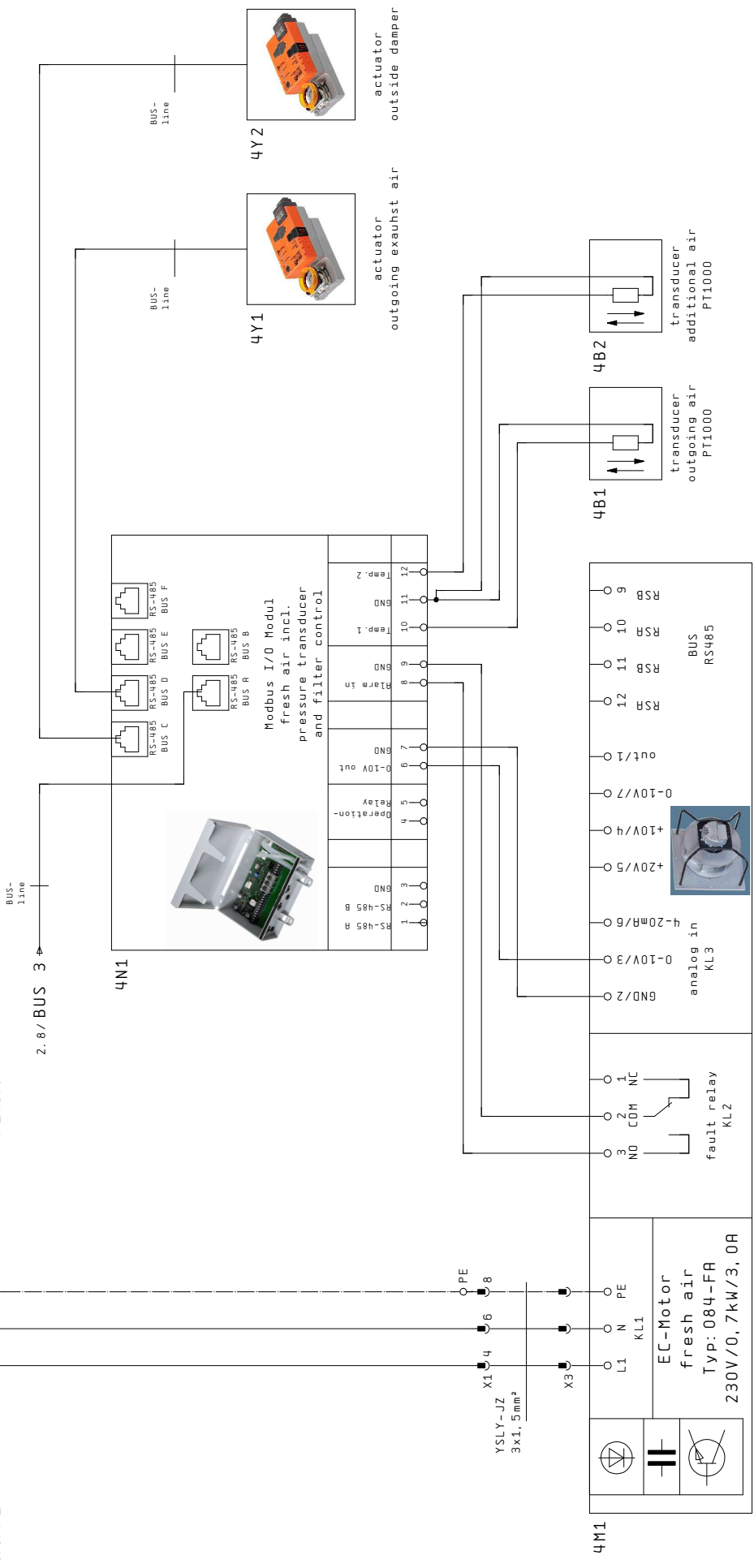
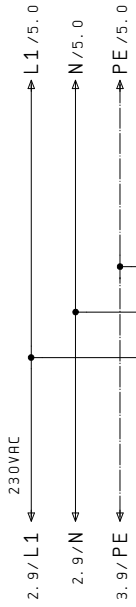

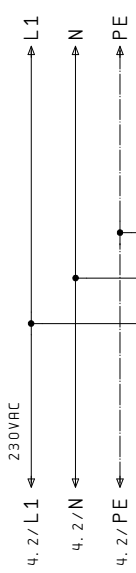

BUS-line  
 2. 8 / BUS 4

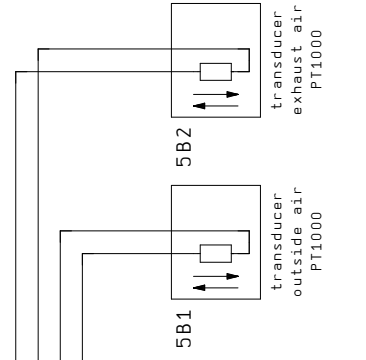
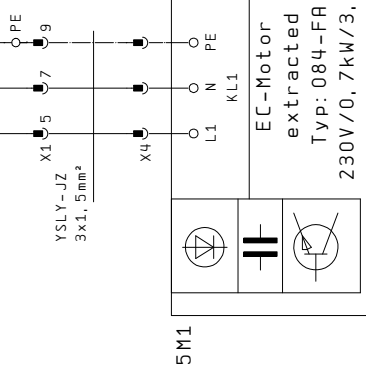
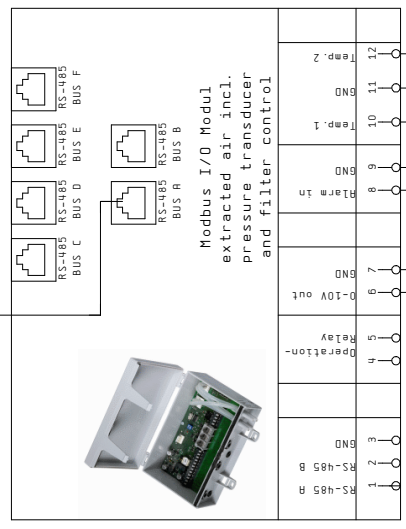

K-level = 70









# Bill of materials

MUP0001E 01.03.1994

Item designation	Amount	Designation	Type number	Supplier	Article number
<b>terminal-material:</b>					
terminal stop	2	X1/X2		Wago	249-117
PE-terminal 2.5mm²	2	X1/X2		Wago	280-907
terminal 2.5mm² grey	4	X1		Wago	280-901
double deck terminal 2.5mm grey	11	X2		Wago	870-501
cover plate double deck terminal	1	X2		Wago	870-518
double deck terminal PE pluggable	1	X2		Wago	870-107
double deck terminal grey pluggable	2	X2		Wago	870-101
cover plate pluggable	1	X1		Wago	870-118
endmodul 45° pluggable PE	2	X1		Wago	769-515
middlemodul 45° pluggable grey	2	X1		Wago	769-513
startmodul 45° pluggable grey	2	X1		Wago	769-512
MBS- terminal name 1-10	2	X1/X2		Wago	793-5599
terminal bridge	2	X2		Wago	870-402

	Date	08.08.16	Date	10.02.17	Date	5.7.0	<b>drawer</b> MSR 230AC Original	 Sub. f.	X-Cube C/R (L)/P/1230/1800 Sub. b.	bill of materials part 2	<b>draw. - No. : 12-1003A</b> R35139	=		
Changes	Date	Name	Norm	5.7.0	Tested	10.02.17								+ P. 9
														9 P.

**D      Circuit diagram, controls tray, 230 V AC-RWT**



# TROX GmbH

Heinrich-Trox-Platz  
47504 Neukirchen-Vluyn  
E-Mail: trox@trox.de, Internet: www.trox.de

Customer :  
Type : drawer MSR 230VAC X-Cube C/R (L)/R/1300  
Project name :  
Article no. : A28140

Manufacturer (Firm) : TROX  
File name (\EPLAN4\P) : 12-1001-A  
Project name :

Index. 00-1/17

Created on : 10.10.12 by : JK Highest Page No. : 9  
Processed on : 10.02.17 by : JK No. of pages : 13

Changes	Date	Name	Norm	Date	Editor	Tested	Drawer	X-Cube C/R (L)/R/1300	cover page	draw. -No. : 12-1001A	=
			5.7.0	08.08.16	JK		MSR 230AC	X-Cube C/R (L)/R/1300			
				10.02.17						A28140	+

P. 0.1  
9 P.

0.2

# Page overview

ESSJ001E

Page	Designation	Additional field	Date	Revisor
0.1	cover page		08.08.16	JK
0.2	page overview		08.08.16	JK
0.3	drawer design		08.08.16	JK
1	main supply		08.08.16	JK
2	VVX-Controller, Cable-Adapter		08.08.16	JK
3	X-Cube control Master		08.08.16	JK
3.1	X-Cube control Master example sample-wiring		08.08.16	JK
4	X-Cube I/O FAN Modul/ fresh air ventilator		08.08.16	JK
5	X-Cube I/O FAN Modul/ extracted air ventilator		08.08.16	JK
6	terminal X1		08.08.16	JK
7	terminal X2		08.08.16	JK
8	bill of materials part 1		08.08.16	JK
9	bill of materials part 2		08.08.16	JK

Date	Name	Norm	5.7.0
	Editor	JK	
	Tested	10.02.17	

drawer  
MSR 230AC  
Original



X-Cube C/R  
(L)/R/1300  
Sub. b.

page overview

draw. - No. : 12-1001A  
R28140

600

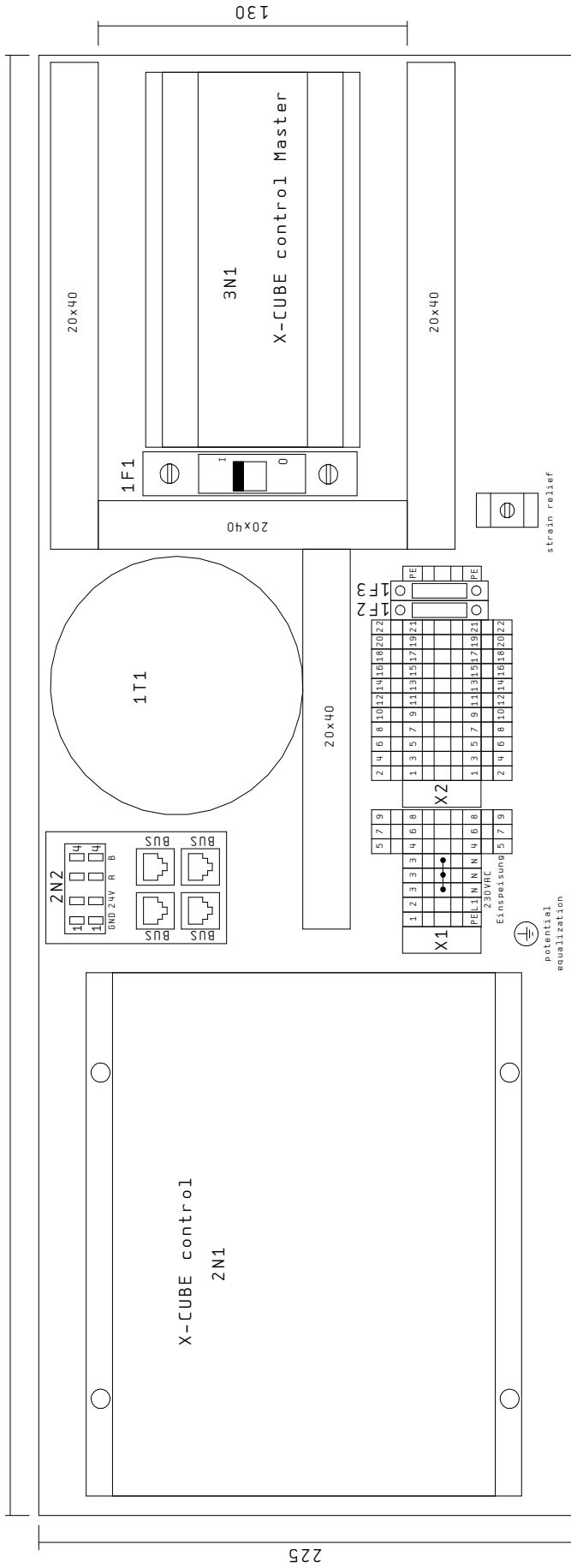

potential  
equalization

strain relief

Date	08. 08. 16	drawer	X-Cube C/R	drawer design	draw. - No. : 12-1001A	
Editor	JK	MSR 230AC	(L)/R/1300			
Tested	10. 02. 17	Original	Sub. f.		R28140	P. 0. 3
Name	5. 7. 0		Sub. b.			9 P.

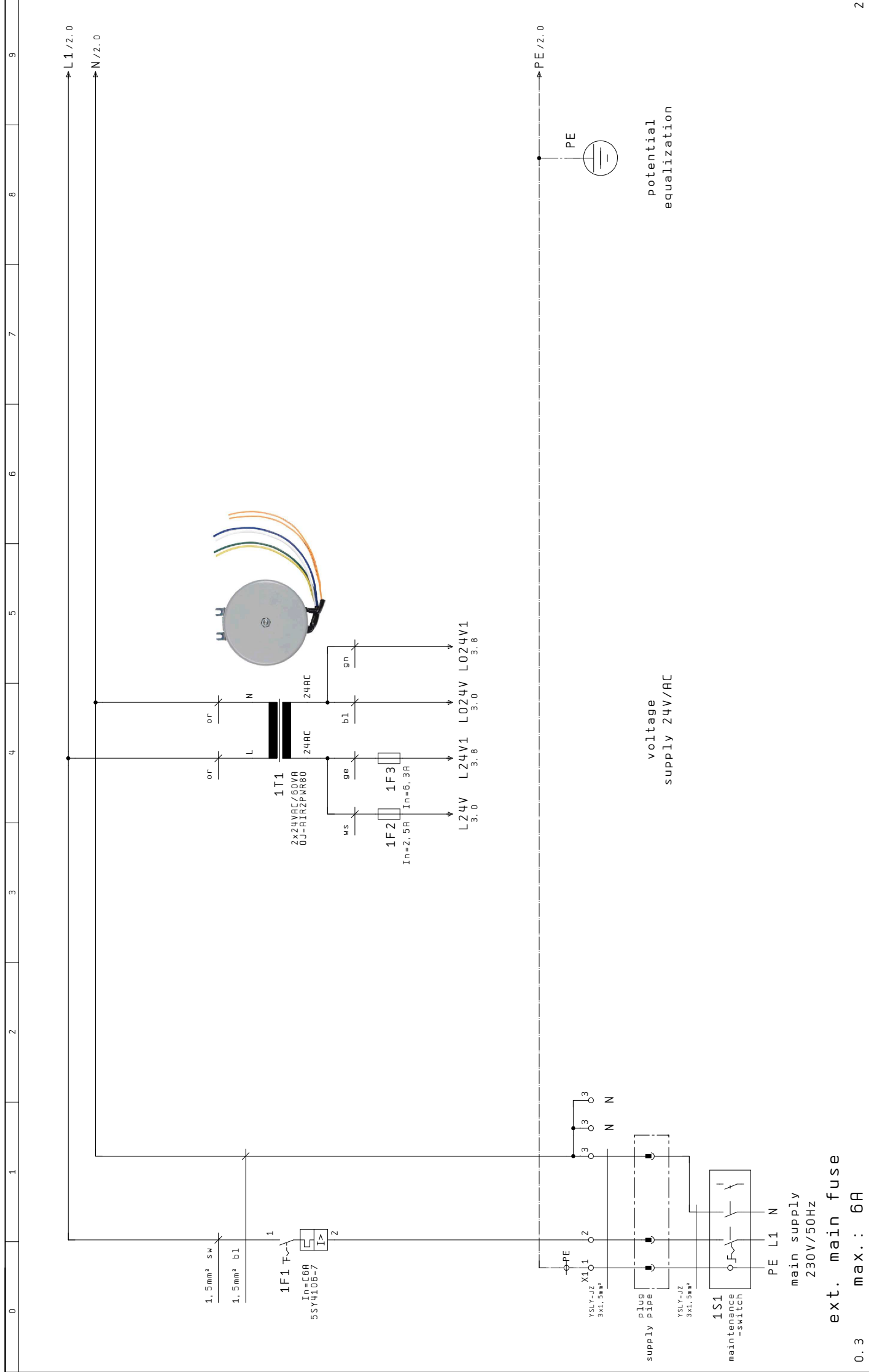

0.3 ext. main fuse max.: 6A

Changes	Date	Name	Norm	Date	Editor	Drawer	X-Cube C/R	main supply	draw. -No. : 12-1001A	Page
				08.08.16	JK	MSR 230AC	(L)/R/1300			1
				10.02.17		Original			R28140	9 P.
				5.7.0						

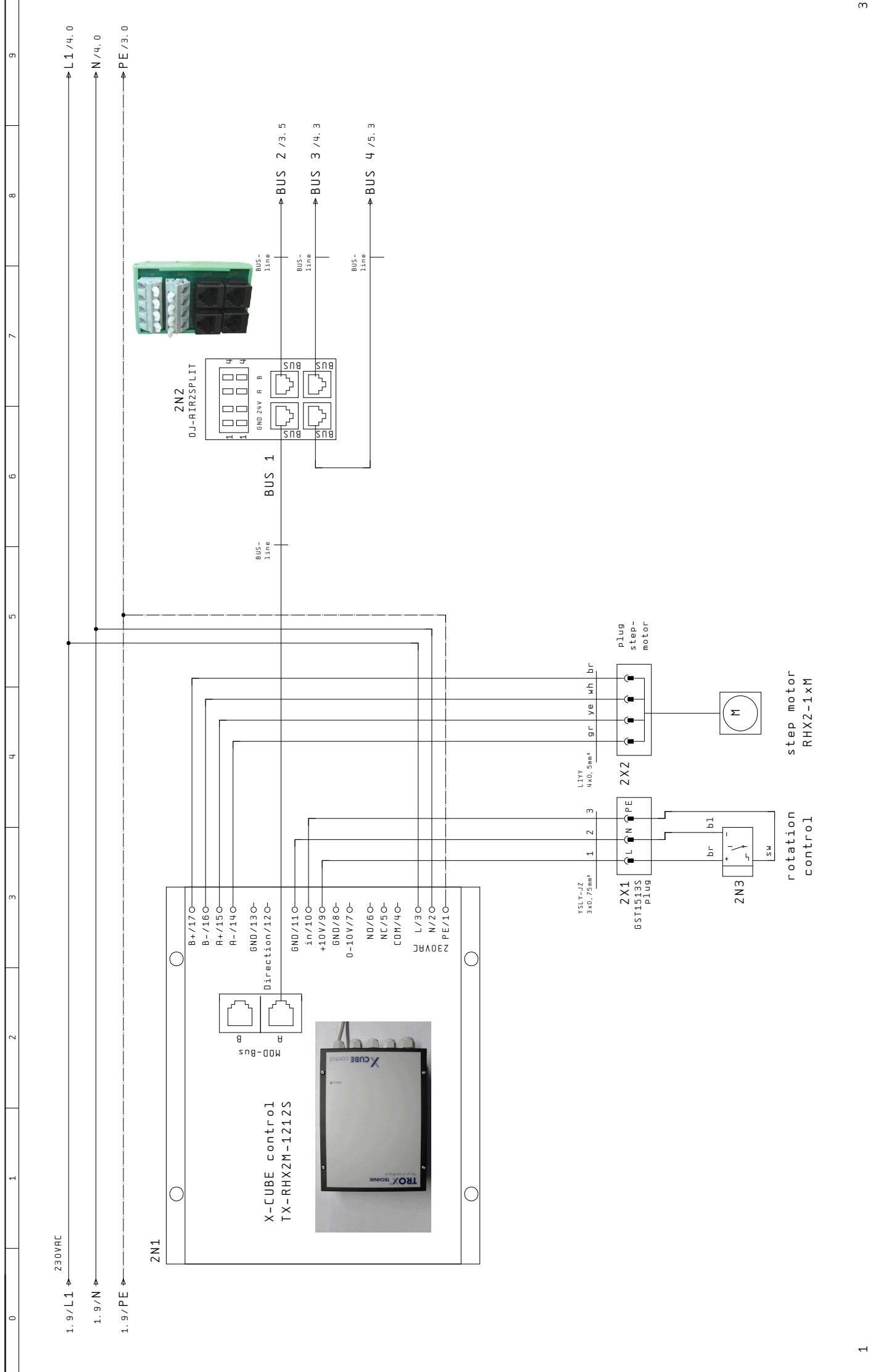



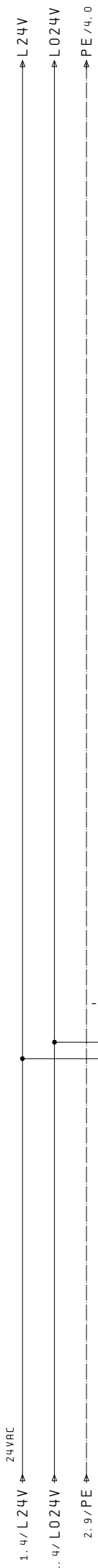

**! attention!**  
 it consists danger from  
 irreparable defect to X CUBE control Master!  
 never connect voltage supply 24 Volt AC  
 from X CUBE control master  
 with digital in and analog input and output.

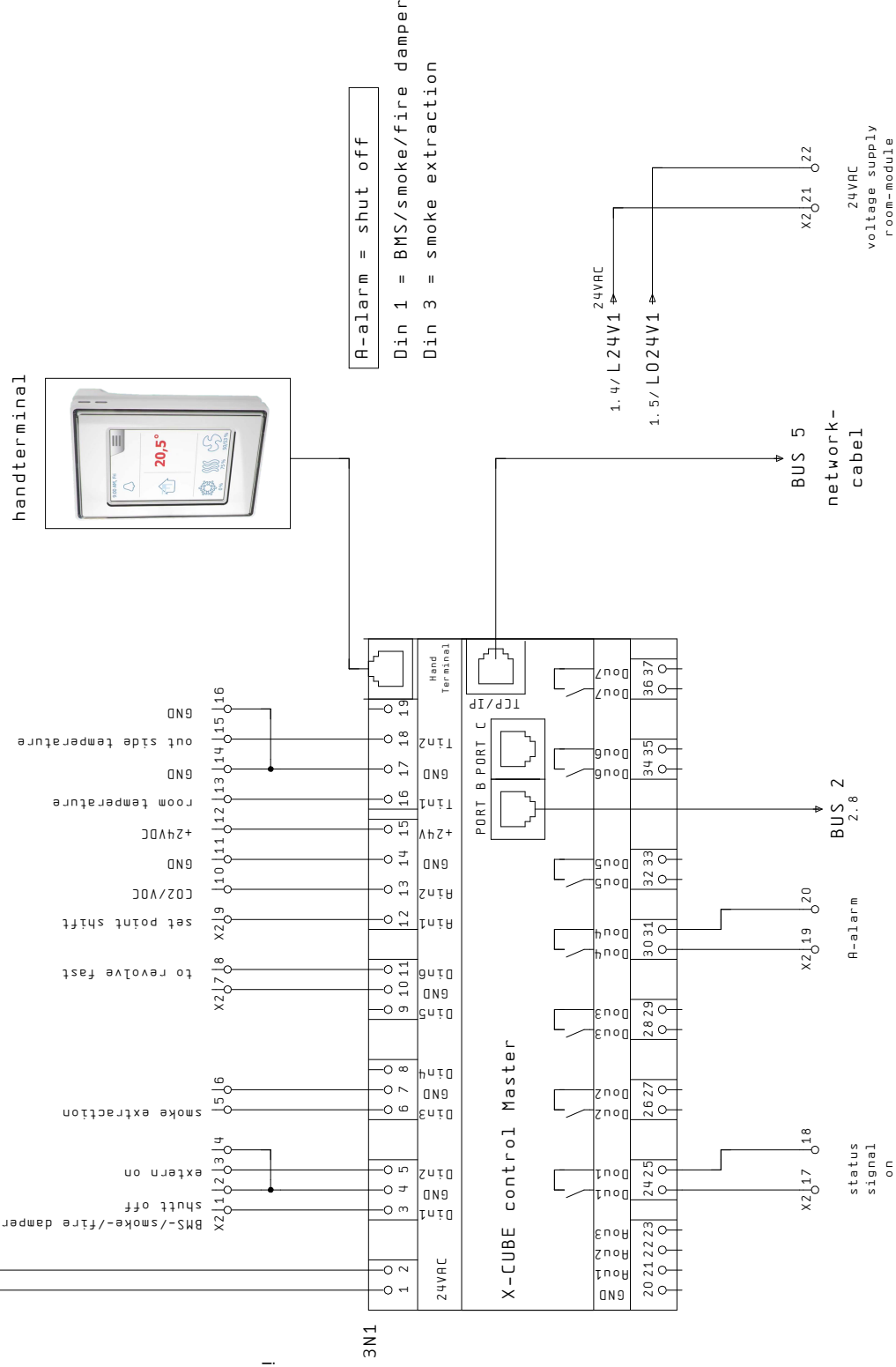
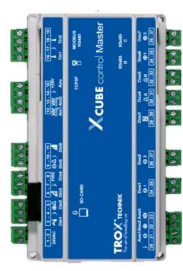

**A-alarm = shut off**  
 Din 1 = BMS/smoke/fire damper  
 Din 3 = smoke extraction

changes	Date	Name	Norm	5.7.0	Original	drawer MSR 230AC	Date	08.08.16	Editor	JK
						X-Cube C/R (L)/R/1300				
						X-Cube control Master				
						draw. -No.: 12-1001A				
						R28140				
						P. 3				
						9 P.				

# example sample-wiring

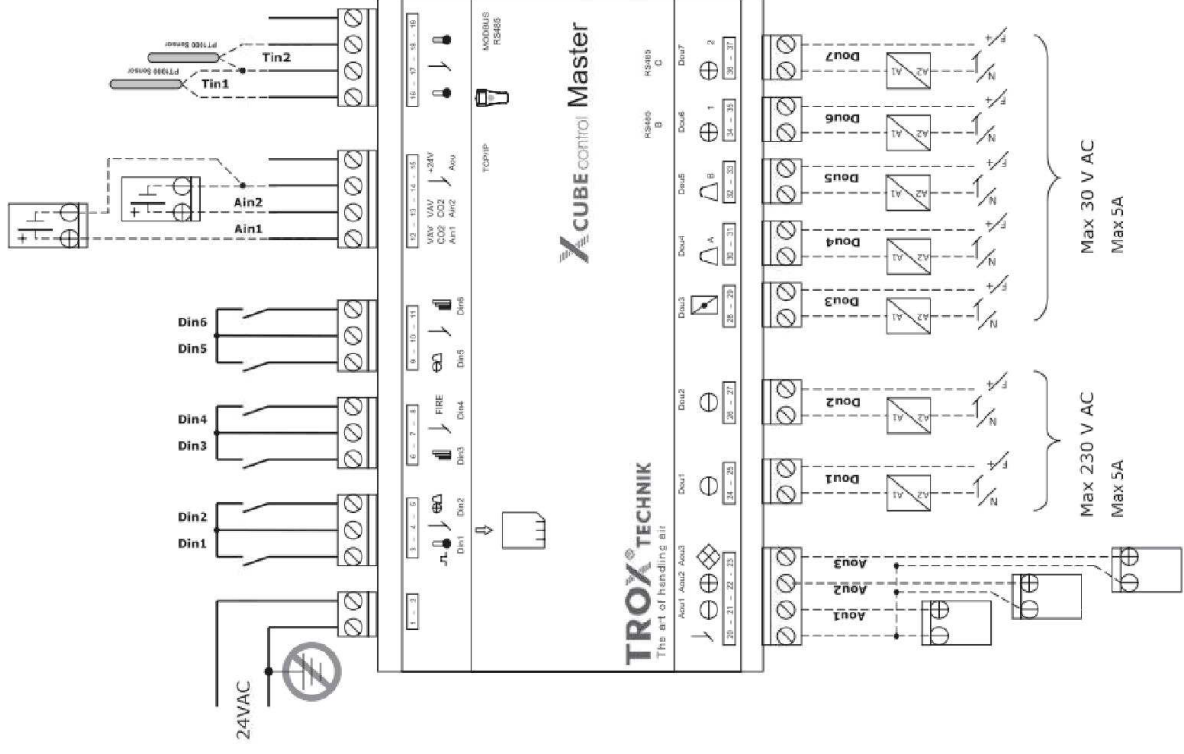

digital in

Din 1-6 to be potential free connected

digital out

7-potential free out put  
Dou 1&2 max. 230V/AC/DC max. 5A  
Dou 3-7 max. 30V/AC/DC max. 5A

analog in

Ain 1&2 signal input range 0-10V  
voltage supply 24VDC for active sensor terminal 14 (GND)  
terminal 15 (+24VDC)

analog out

Aou 1-3 signal out range 0-10V  
common ground terminal 20 (GND)

	Date	08.08.16	drawer	X-Cube C/R	X-Cube control Master	draw. -No.: 12-1001A	
	Editor	JK	MSR 230AC	(L)/R/1300	example		
	Tested	10.02.17	Original		sample-wiring	R28140	
Changes	Date	Name	Norm	Sub. b.	Sub. f.		
			5.7.0				
							P. 3.1
							9 P.

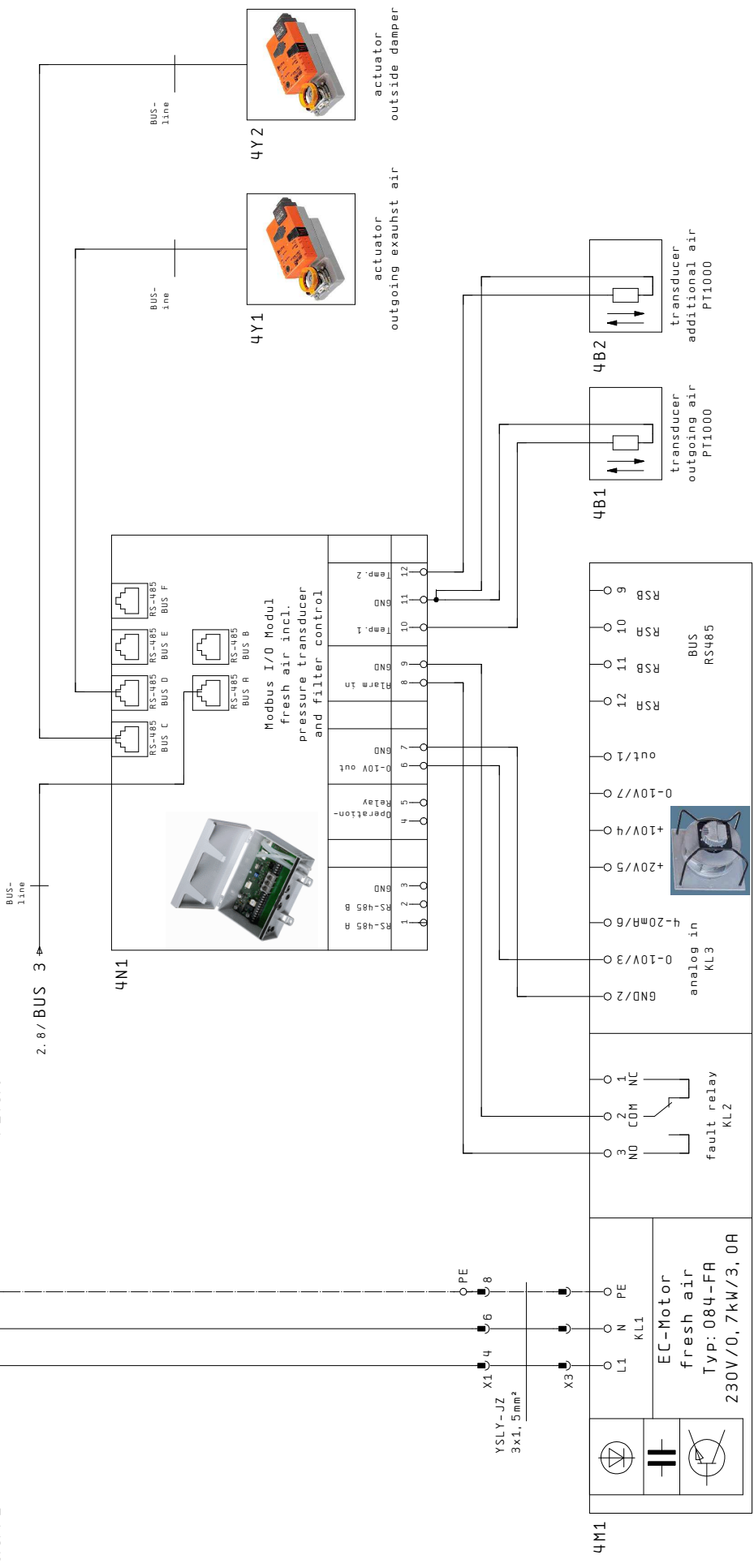
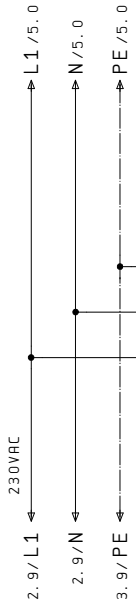

K-level = 70

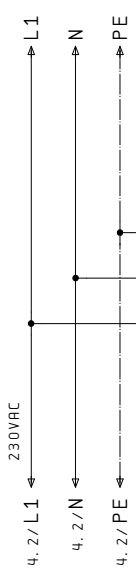

BUS-  
line  
 2. 8/ BUS 4

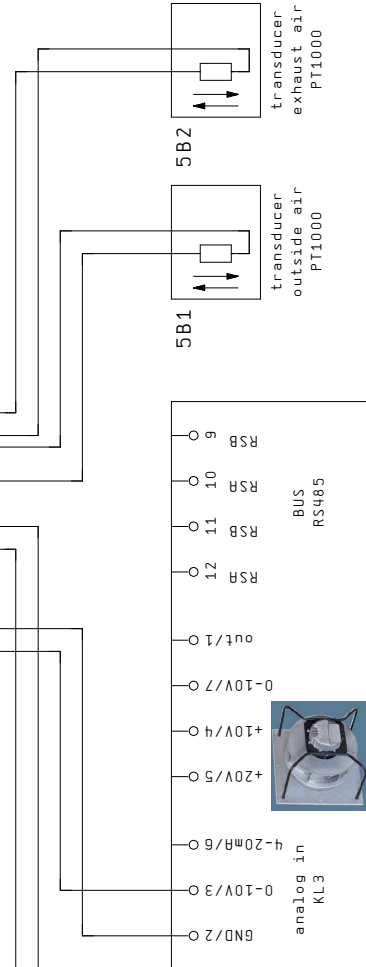
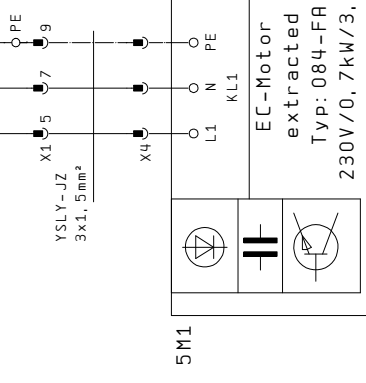
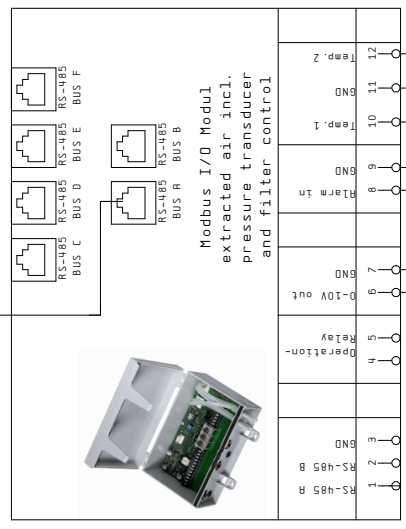

K-level = 70

Page / path

1.0  
1.1  
1.1  
1.1  
1.2  
4.1  
5.1  
4.1  
5.1  
4.33:69  
5.33:69

Terminal strip designation		Cable designation	Cable type	Connection	Destination	Terminal name	Terminal number	Connection
X1								
				2		PE	1	
				N		1F1	2	
						1T1	3	
							4	
	X3			L/3		2N1	5	
	X4			N/2		L1	6	
						2N1	7	
						N	8	
						PE	9	
						PE		

Cable designation	Cable type	Function
YSLV-JZ 3x1.5mm²		main supply PE
YSLV-JZ 3x1.5mm²		main supply L1
YSLV-JZ 3x1.5mm²		main supply N
		Einspeisung N
		*
	1	voltage supply fresh air motor L1
	1	voltage supply extracted motor L1
		voltage supply fresh air motor N
		voltage supply extracted motor N
		voltage supply fresh air motor PE
		voltage supply extracted motor PE

Date	08.08.16	Editor	JK	Tested	10.02.17	Norm	5.70
Name	dr awer		MSR Z30AC		Original	Sub. f.	
Date	X-Cube C/R		(L)/R/1300		Original	Sub. b.	
terminal X1				draw. - No. : 12-1001H			
				P. 6			
				9 P.			



# Bill of materials

WUP0001E 01.03.1994

Item designation	Amount	Designation	Type number	Supplier	Article number
<b>Hardware:</b>					
drawer steel plate 750x225mm	1	1		TRDX	
X-Cube Control Master	1	3M1		TRDX	A00000027516
transformer PMR	1	1F1		TRDX	A00000027522
WR6-controller	1	2M1		TRDX	A00000027521
Mod-Bus cable connector	1	2N2		TRDX	A00000027528
plug sensor	1	2X1		Wieland	6ST1513S
plug supply pipe	1	1X1		Wieland	76.352.0736.0
circuit breaker C6A	1	1F1		Siemens	5SY4106-7
safty clip	2	1F2/1F3		Weidmüller GmbH & Co.	ASK 1/35
micro fuse 2.5A T 5x20mm	1	1F2		Sonepar	
micro fuse 6.3A T 5x20mm	1	1F3		Sonepar	
DIN rail TS95	50cm			Licotec	
cable 3x1.5mm²	60cm	cable supply pipe		Sonepar	YSLY-JZ 3x1.5mm²
cable 3x0.75mm²	40cm	cable sensory		Sonepar	YSLY-JZ 3x0.75mm²
cable duct 20x40mm	40cm			Licotec	
snap in clamp	1			0B0	2105 012
AWM modular-plug	6			Sonepar	1290053
telefoncabel 6-core flat	100cm			Sonepar	1209571
raised head screw 4x20mm	4			van Beusekom	
raised head screw 4x4mm	15			van Beusekom	
network cable 1m	1			Sonepar	





**E      Circuit diagram, controls tray, 400 V AC-PWT**



# TROX GmbH

Heinrich-Trox-Platz  
 47504 Neukirchen-Vluyn  
 E-Mail: trox@trox.de, Internet: www.trox.de

Customer :  
 Type : drawer MSR 400VAC X-Cube C/R (L)/P/2400/3600  
 Project name :  
 Article no. : A35140

Manufacturer (Firm) : TROX  
 File name (\EPLAN4\P) : 12-1004-A  
 Project name :  
 :  
 :  
 :  
 :

Index. 00-8/16

Created on : 16.10.12 by : JK Highest Page No. : 9  
 Processed on : 08.08.16 by : JK No. of pages : 13

Changes	Date	Name	Norm	5.7.0	Tested	08.08.16	Editor	JK	Date	08.08.16	drawer	MSR 400AC	Original	Sub. f.	Sub. b.	X-Cube C/R (L)/P/2400/3600	cover page	draw. - no. : 12-1004A	=	+	P. 0.1	9 P.

**Page overview**

ESSJ001E

Page	Designation	Additional field	Date	Revisor
0.1	cover page		08.08.16	JK
0.2	page overview		08.08.16	JK
0.3	drawer design		08.08.16	JK
1	main supply		08.08.16	JK
2	Cable-Adapter		08.08.16	JK
3	X-Cube control Master		08.08.16	JK
3.1	X-Cube control Master example sample-wiring		08.08.16	JK
4	X-Cube I/O FAN Modul/ fresh air ventilator		08.08.16	JK
5	X-Cube I/O FAN Modul/ extracted air ventilator		08.08.16	JK
6	terminal X1		08.08.16	JK
7	terminal X2		08.08.16	JK
8	bill of materials part 1		08.08.16	JK
9	bill of materials part 2		08.08.16	JK

			X-Cube C/R (L)/P/2400/3600	page overview	= +
drawer MSR 400AC Original				draw. - no. : 12-1004A	
Date 08.08.16 Editor JK Tested 08.08.16 Name 5.7D Norm				R35140	P. 0.2 9 P.



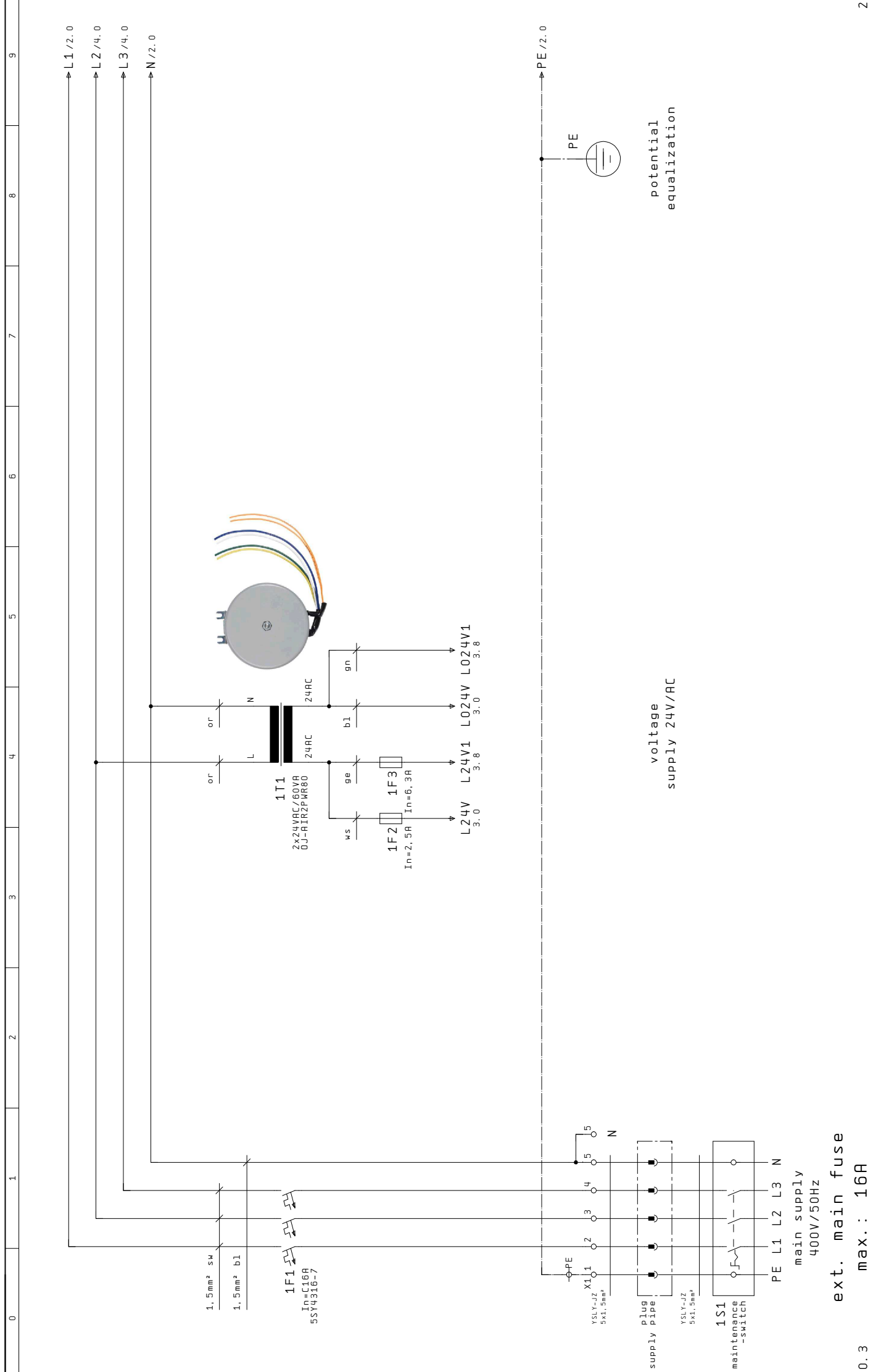

Changes	Date	Name	Norm	5.7D	08.08.16	08.08.16	08.08.16	08.08.16	08.08.16
		Editor			JK				
		Tested							

draw. -no.:	12-1004A	=
R35140		+
P.:	1	
		9 P.

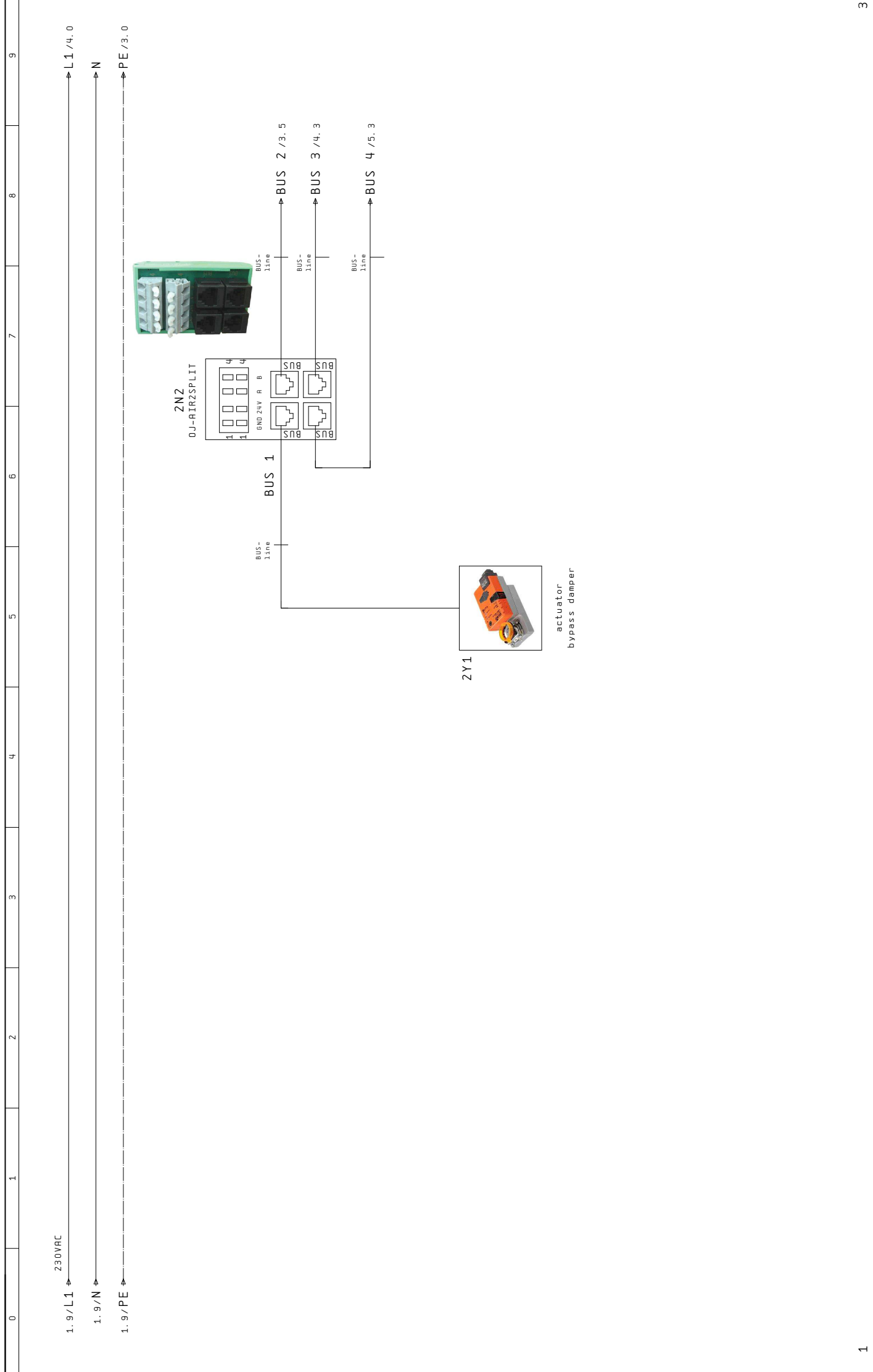

Changes	Date	Name	Norm	5.7.0	Tested	08.08.16	Editor	JK	Date	08.08.16	drawer MSR 400AC	Original	X-Cube C/R (L)/P/2400/3600	Sub. b.	CUBE compact	Cable-Adapter	draw. -no.: 12-1004A	=	+
	Date	Name	Norm	5.7.0	Tested	08.08.16	Editor	JK	Date	08.08.16	drawer MSR 400AC	Original							
R35140																			
P. 2																			
9 P.																			



# example sample-wiring

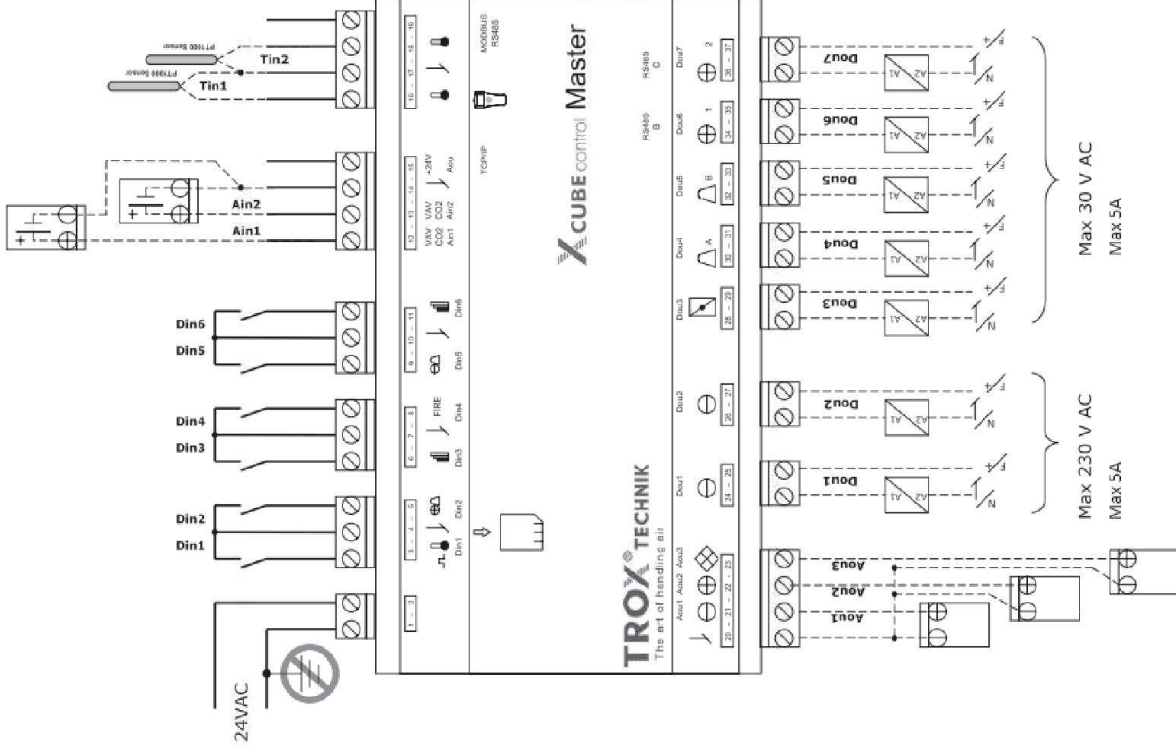

digital in

Din 1-6 to be potential free connected

digital out

7-potential free out put  
 Dou 1&2 max. 230V/AC/DC max. 5A  
 Dou 3-7 max. 30V/AC/DC max. 5A

analog in

Ain 1&2 signal input range 0-10V  
 voltage supply 24VDC for  
 aktive sensor terminal 14 (GND)  
 terminal 15 (+24VDC)

analog out

Aou 1-3 signal out range 0-10V  
 common ground terminal 20 (GND)

Max. 5A                      Max. 5A  
 Max. 30 V AC            Max. 5A

Date	08.08.16	drauer	X-Cube C/R (L)/P/2400/3600	X-Cube control Master example sample-wiring	draw. -no.: 12-1004A
	Editor JK	MSR 400AC			
Date	08.08.16	Original	Sub. b.		
Name	5.7.0				
Tested					
Norm					
					P. 3.1
					9 P.



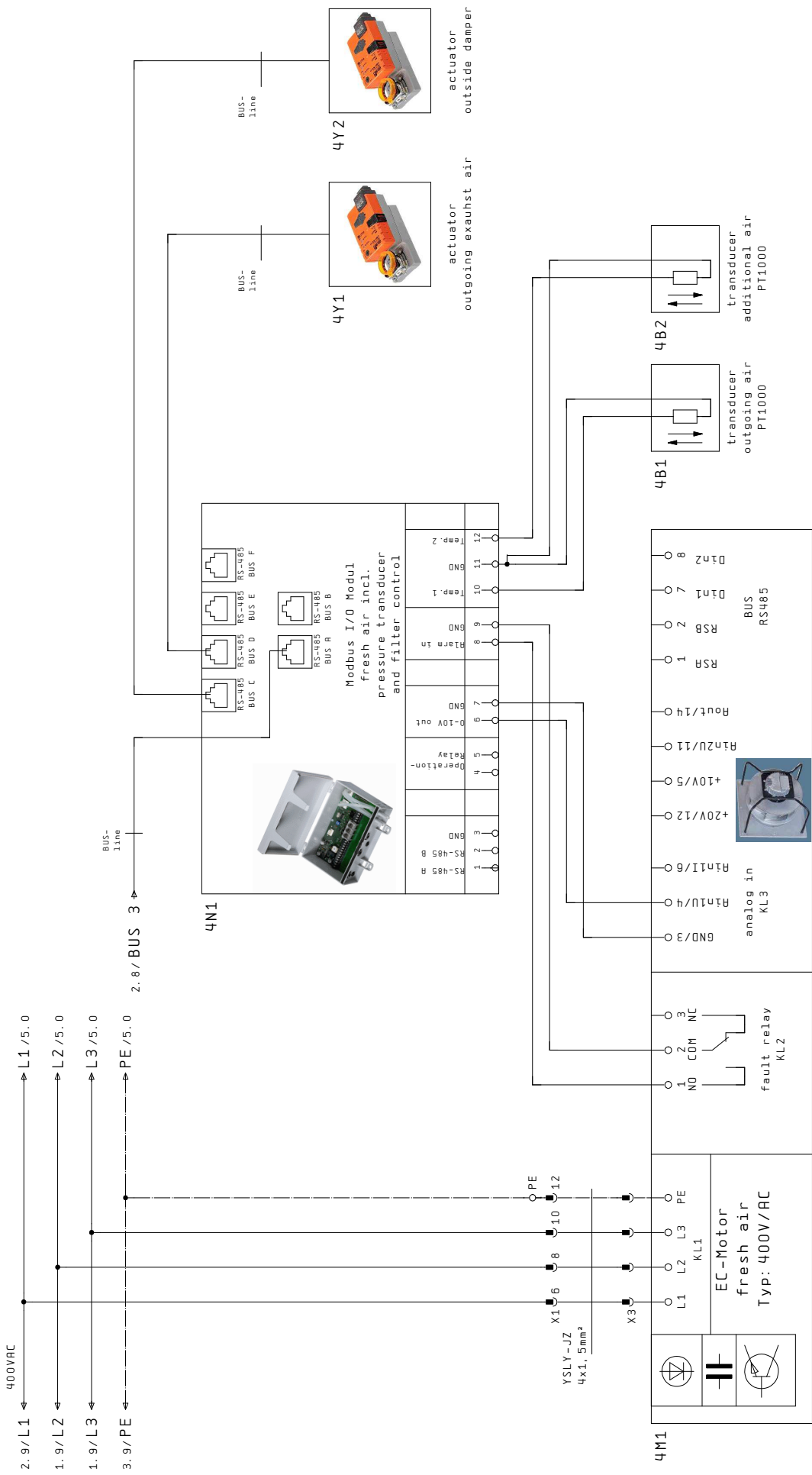

Typ:	Motor:	[kW]:	[A]:	K-level:
2400	112-6A	1,65	2,5	116
3600	112-6A	1,7	2,7	148

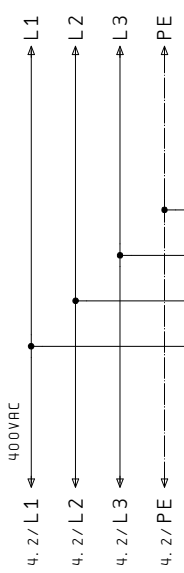

2. 8/ BUS 4

BUS-line

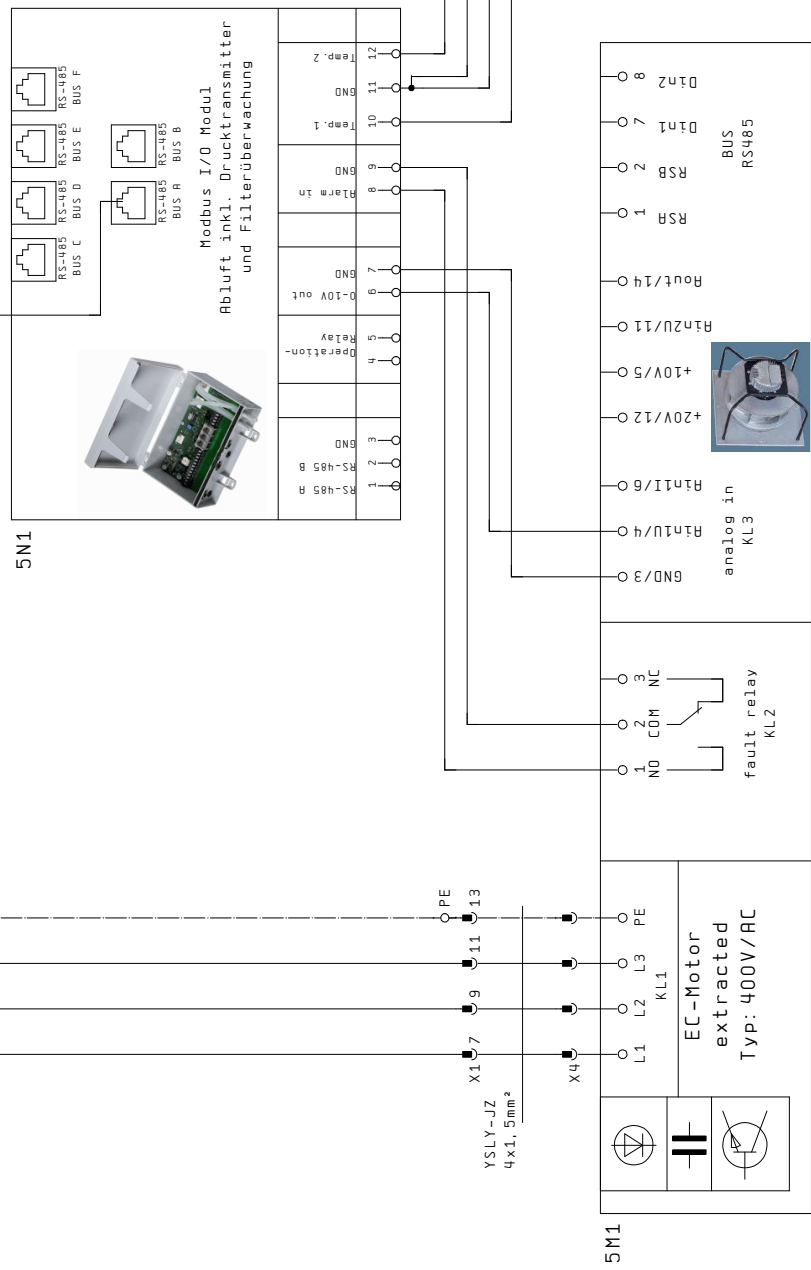

Typ:	Motor:	[kW]:	[A]:	K-level:
2400	112-6A	1,65	2,5	116
3600	112-6A	1,7	2,6	148



Page / path	0	1	2	3	4	5	6	7	8	9
Terminal strip designation	Cable designation									
	Cable type									
	Connection									
	Destination									
	Terminal name									
	Terminal number	1	2	3	4	5	6	7	8	9
	Connection	3N1	3N1	3N1	3N1	3N1	3N1	3N1	3N1	3N1
	Destination									
	Cable type	3N1	3N1	3N1	3N1	3N1	3N1	3N1	3N1	3N1
	Connection	3N1	3N1	3N1	3N1	3N1	3N1	3N1	3N1	3N1
X2	Cable designation									
	Cable type									
	Connection									
	Destination									
	Terminal name									
	Terminal number	1	2	3	4	5	6	7	8	9
	Connection	3N1	3N1	3N1	3N1	3N1	3N1	3N1	3N1	3N1
	Destination									
	Cable type	3N1	3N1	3N1	3N1	3N1	3N1	3N1	3N1	3N1
	Connection	3N1	3N1	3N1	3N1	3N1	3N1	3N1	3N1	3N1
Function	Cable designation									
	Cable type									
	Connection									
	Destination									
	Terminal name									
	Terminal number	1	2	3	4	5	6	7	8	9
	Connection	3N1	3N1	3N1	3N1	3N1	3N1	3N1	3N1	3N1
	Destination									
	Cable type	3N1	3N1	3N1	3N1	3N1	3N1	3N1	3N1	3N1
	Connection	3N1	3N1	3N1	3N1	3N1	3N1	3N1	3N1	3N1

# Bill of materials

MUP0001E 01.03.1994

Item designation	Amount	Designation	Type number	Supplier	Article number
<b>Hardware:</b>					
drawer steel plate	1	1		TROX	
X-Cube Control Master	1	3M1		TROX	A00000027516
transformer PMR	1	1T1		TROX	A00000027522
Mod-Bus cable connector	1	2N2		TROX	A00000027528
plug sensor	1	2X1		Wieland	6ST1513S
plug supply pipe	1	1X1		Wieland	76.352.0736.0
circuit breaker 3po.C16A	1	1F1		Siemens	5SY4316-7
safy clip	2	1F2/1F3		Weidmüller GmbH & Co.	ASK 1/35
micro fuse 2.5A T 5x20mm	1	1F2		Sonepar	
micro fuse 6.3A T 5x20mm	1	1F3		Sonepar	
DIN rail TS95	50cm			Licatec	
cable 5x1.5mm²	60cm	cable supply pipe		Sonepar	YSLY-JZ 3x1.5mm²
cable duct 20x60mm	75cm			Licatec	
snap in clamp	1			OBO	2105 012
AWM Modular-Stecker	6			Sonepar	1290053
telefoncabel 6-core flat	120cm			Sonepar	1209571
raised head screw 4x20mm	4			van Beusekom	
raised head screw 4x4mm	15			van Beusekom	
network cable 1.5m	1			Sonepar	

Changes	Date	Name	Norm	5.7.0	08.08.16	Editor	JK	08.08.16	Tested	MSR 400AC	Original	Sub. f.	Sub. b.	X-Cube C/R (L)/P/2400/3600	bill of materials part 1	draw. -no.: 12-1004A	=	+
																R35140		

## Bill of materials

MUP0001E 01.03.1994

Item designation	Amount	Designation	Type number	Supplier	Article number
<b>terminal-material:</b>					
terminal stop	2	X1/X2		Wago	249-117
PE-terminal 2.5mm²	2	X1/X2		Wago	280-907
terminal 2.5mm² grey	5	X1		Wago	280-901
double deck terminal 2.5mm grey	11	X2		Wago	870-501
cover plate double deck terminal	1	X2		Wago	870-518
double deck terminal PE pluggable	1	X2		Wago	870-107
double deck terminal grey pluggable	2	X2		Wago	870-101
cover plate pluggable	1	X1		Wago	870-118
endmodul 45° pluggable PE	2	X1		Wago	769-515
middlemodul 45° pluggable grey	4	X1		Wago	769-513
startmodul 45° pluggable grey	2	X1		Wago	769-512
MBS- terminal name 1-10	2	X1/X2		Wago	793-5599
terminal bridge	1	X2		Wago	870-402

**F      Circuit diagram, controls tray, 400 V AC-RWT**



# TROX GmbH

Heinrich-Trox-Platz  
 47504 Neukirchen-Vluyn  
 E-Mail: trox@trox.de, Internet: www.trox.de

Customer :  
 Type : drawer MSR 400VAC X-Cube C/R (L)/R/2000/3000/4200/5200  
 Project name :  
 Article no. : A28141

Manufacturer (Firm) : TROX  
 File name (\EPLAN4\P) : 12-1002-A  
 Project name :  
 :  
 :  
 :  
 :

Index. 00-8/16

Created on : 16.10.12 by : JK Highest Page No. : 9  
 Processed on : 08.08.16 by : JK No. of pages : 13

Changes	Date	Name	Norm	5.7.0	Tested	08.08.16	Editor	JK	Date	08.08.16	drawer	MSR 400AC	Original	Sub. f.	Sub. b.	X-Cube C/R (L)/R/20/30/42/52	cover page	draw. -No. : 12-1002A	=	+	P. 0.1	9 P.





size 1 = 750mm  
 size 2 = 900mm  
 size 3 = 1050mm  
 size 4 = 1210mm

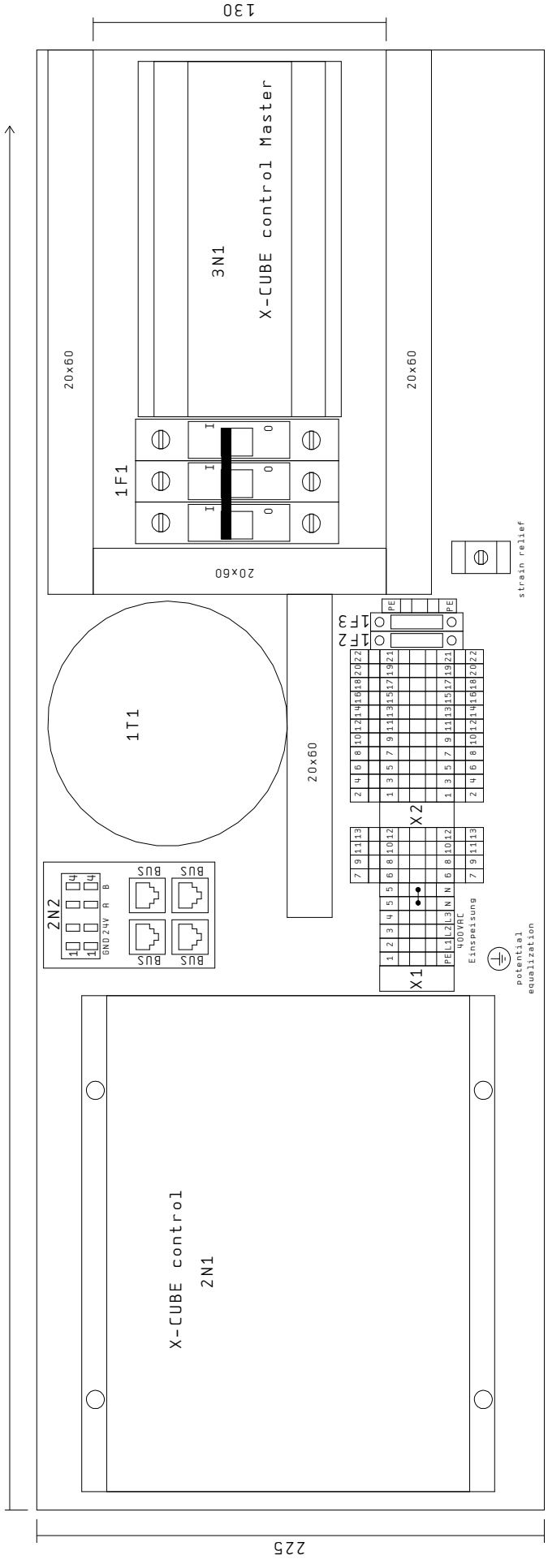

Changes	Date	Name	Norm	5.7.0	Tested	08.08.16	Editor	JK	Date	08.08.16	drawer	MSR 400AC	Original	Sub. f.	Sub. b.	X-Cube C/R (L)/R/20/30/42/52	drawer design	draw. -No.: 12-1002A	R28141	P. 0.3	9 P.
---------	------	------	------	-------	--------	----------	--------	----	------	----------	--------	-----------	----------	---------	---------	---------------------------------	---------------	----------------------	--------	--------	------

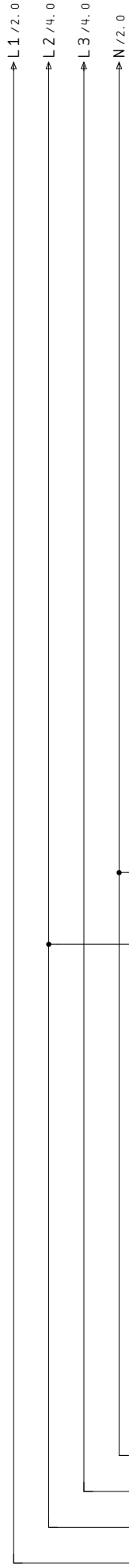

1.5mm<sup>2</sup> sw  
1.5mm<sup>2</sup> b1  
1F1  
In=C16A  
5SY4316-7

1T1  
2x24VAC/60VA  
0J-AIR2P-MR80  
24AC  
24AC  
L  
N  
GN  
GN

1F2  
In=2,5A  
1F3  
In=6,3A  
L24V L24V1 L024V L024V1  
3.0 3.8 3.0 3.8

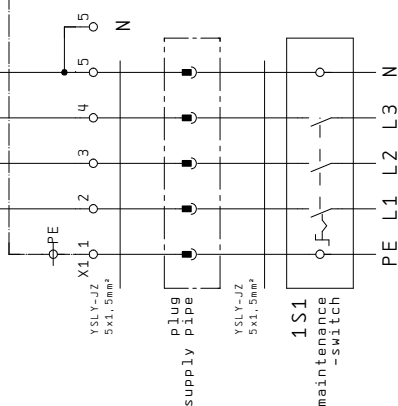

main supply  
400V/50Hz

ext. main fuse  
max.: 16A

potential  
equalization

0.3

Changes	Date	Name	Norm	5.7.0
		Editor	JK	
		Tested		08.08.16
		Date		08.08.16

drawer  
MSR 400AC  
Original



X-Cube C/R  
(L)/R/20/30/42/52  
Sub. f.

main supply

draw. -No.: 12-1002A  
R28141  
P. 1  
9 P.

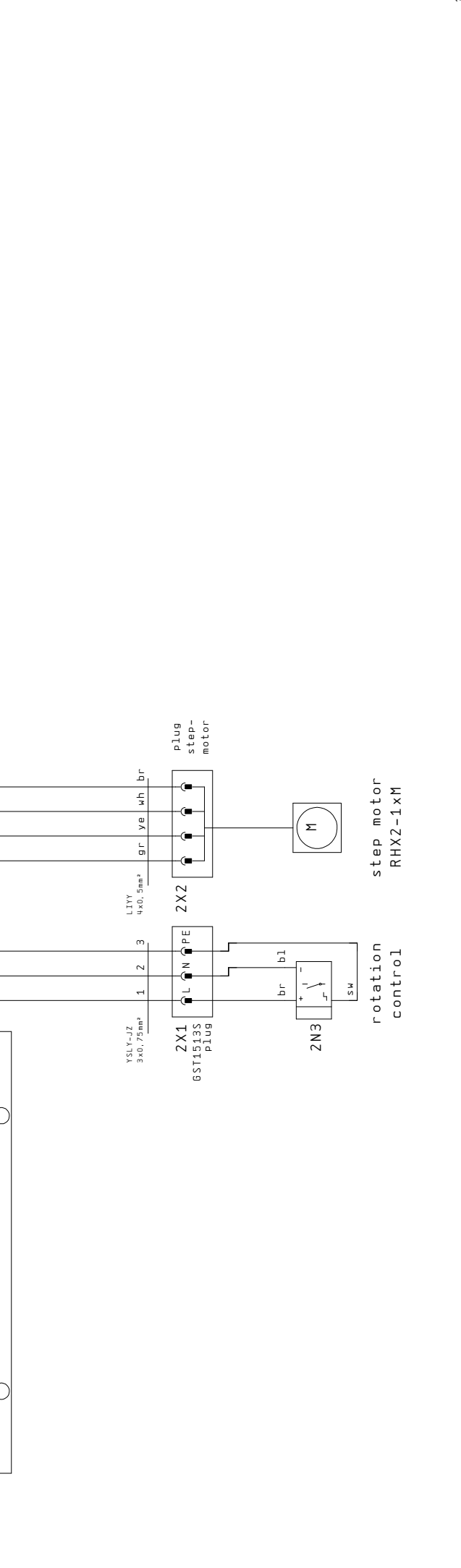
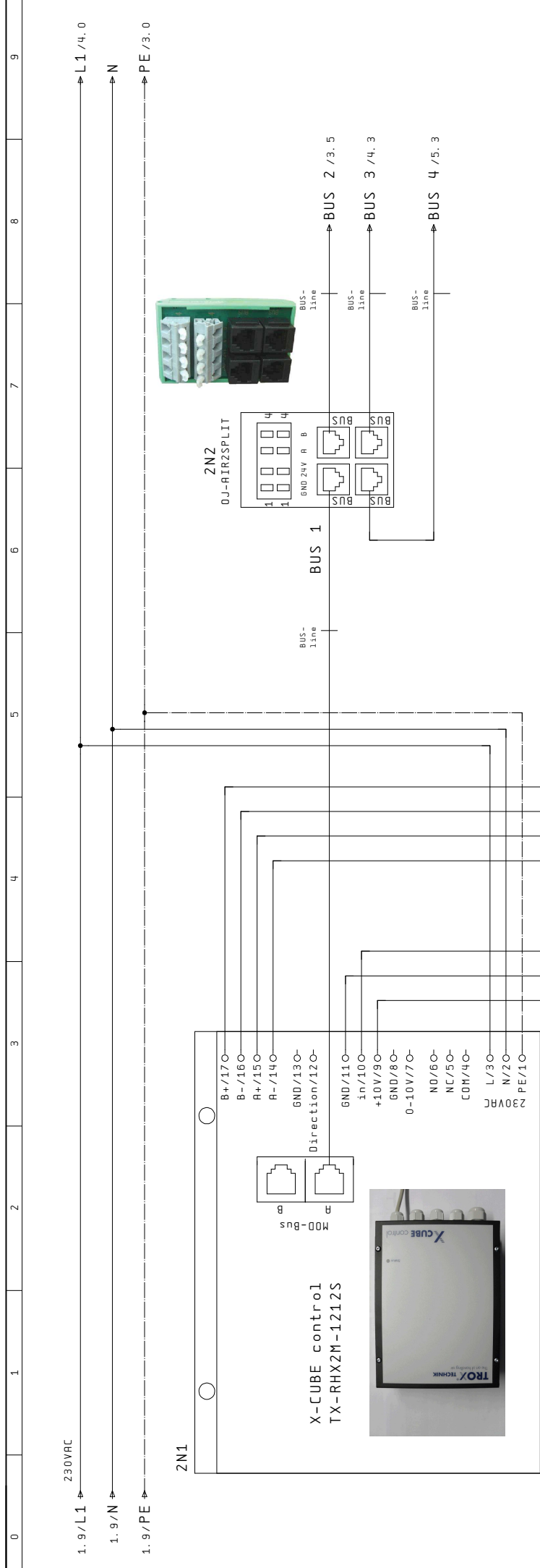

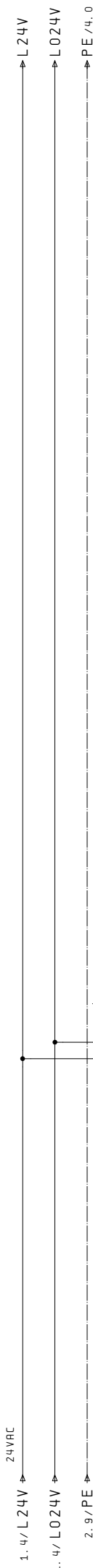

**!! attention!**  
 it consists danger from  
 irreparable defect to X CUBE control Master!  
 never connect voltage supply 24 Volt AC  
 from X CUBE control master  
 with digital in and analog input and output.

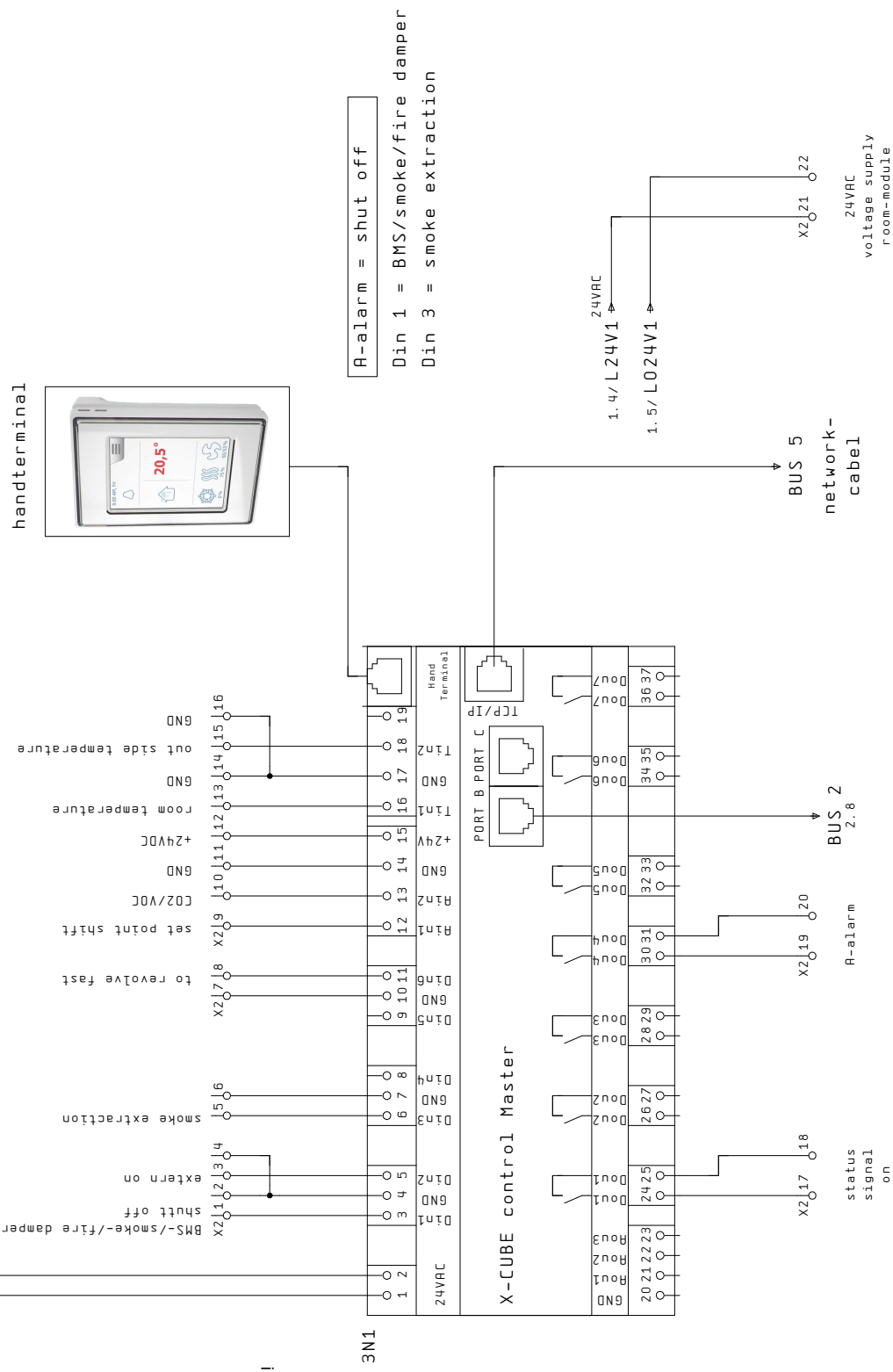
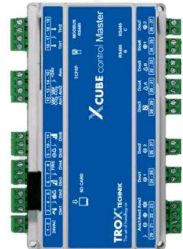

# example sample-wiring

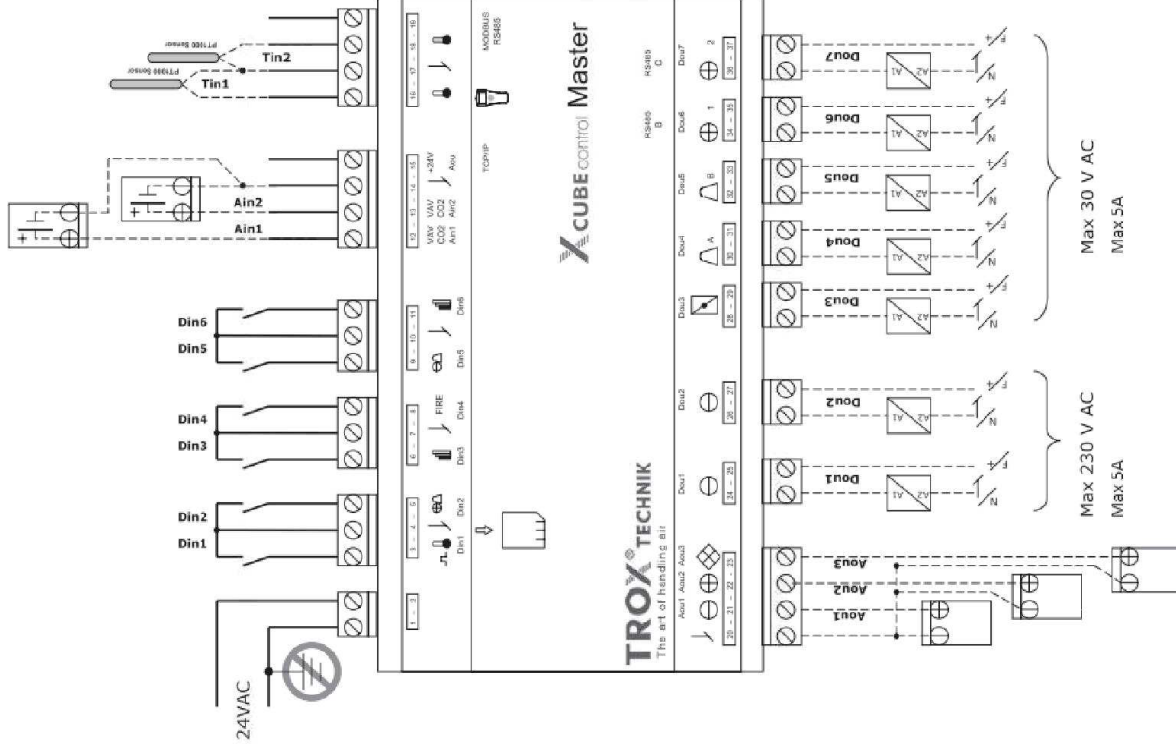

digital in

Din 1-6 to be potential free connected

digital out

7-potential free out put

Dou 1&2 max. 230V/AC/DC max. 5A

Dou 3-7 max. 30V/AC/DC max. 5A

analog in

Ain 1&2 signal input range 0-10V voltage supply 24VDC for active sensor terminal 14 (GND) terminal 15 (+24VDC)

analog out

Rou 1-3 signal out range 0-10V common ground terminal 20 (GND)

Date	08.08.16	drawer	MSR 400AC	Date	08.08.16	X-Cube C/R	(L)/R/20/30/42/52	Date	08.08.16	X-Cube control Master	example	Date	08.08.16	draw. -No. : 12-1002A	Date	08.08.16
	Editor		JK		Sub. b.		Sub. f.		Sub. b.		Sub. f.		Sub. b.			Sub. f.
Tested		Original		Sample-wiring		sample-wiring										
Name																
Norm	5.7D															
P.	3.1															
P.	9.P.															

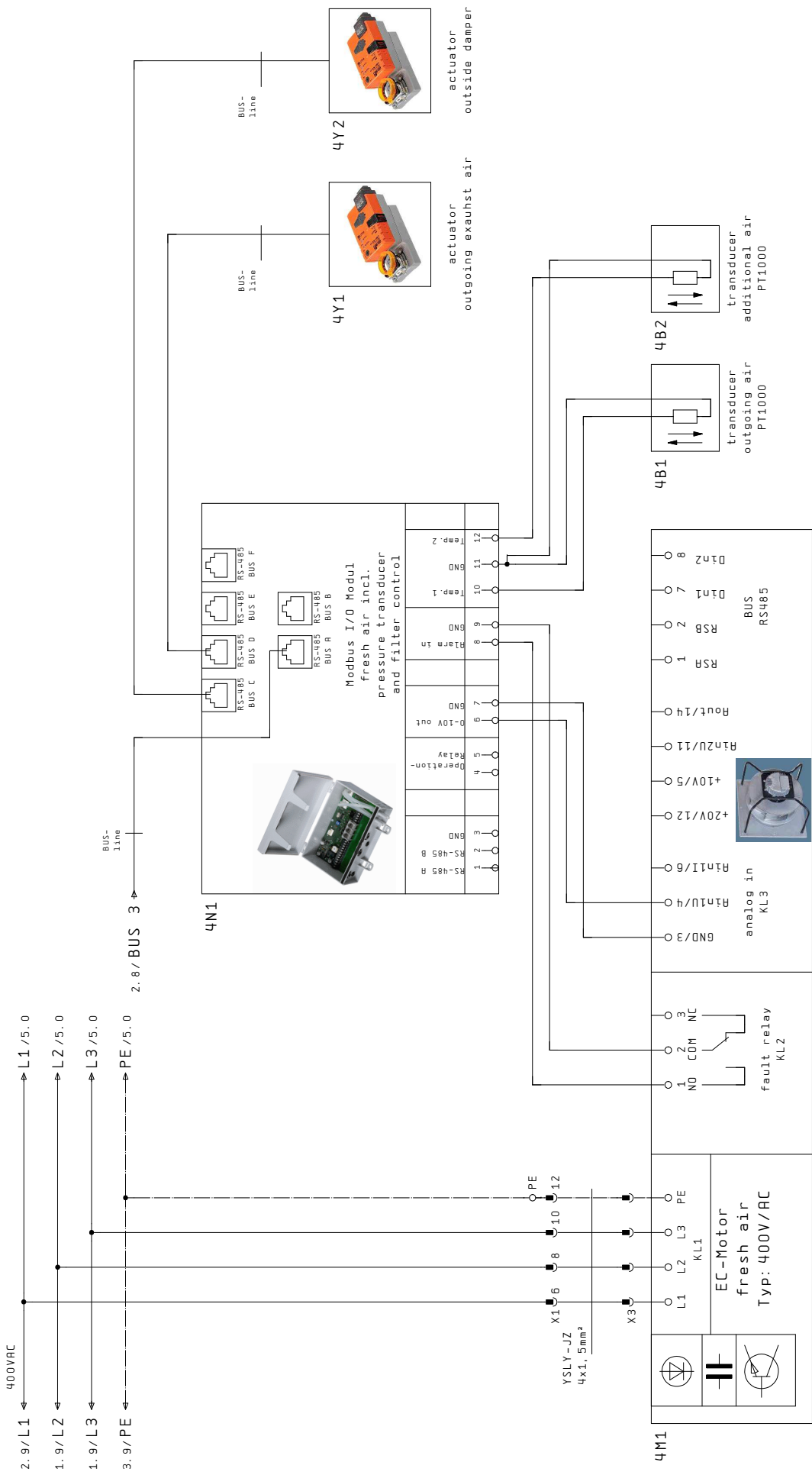

Typ:	Motor:	[kW]:	[A]:	K-level:
2000	084-6F	0,94	1,6	93
3000	112-6A	1,64	2,5	116
4200	112-6A	1,7	2,6	148
5200	150-FF	3	4,6	188

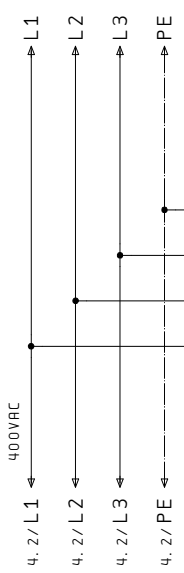

2. 8/ BUS 4

BUS-line

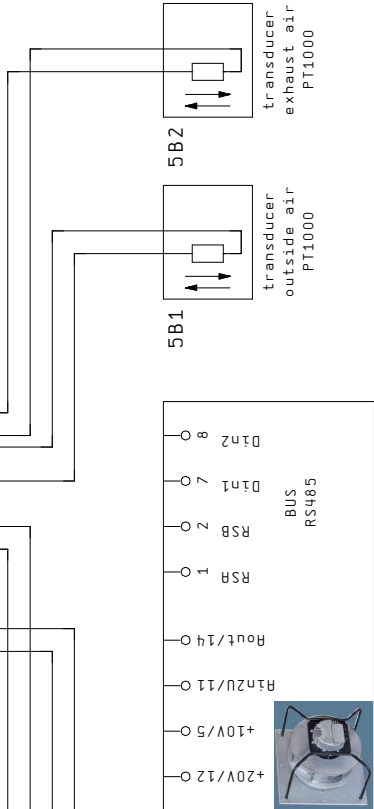
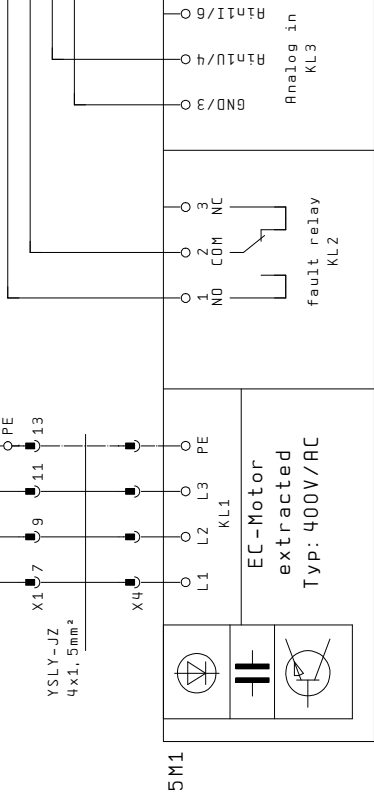
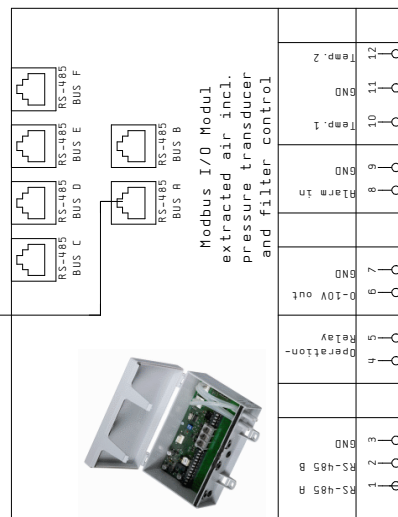

Typ:	Motor:	[kW]:	[A]:	K-level:
2000	084-6F	0,94	1,6	93
3000	112-6A	1,64	2,5	116
4200	112-6A	1,7	2,6	148
5200	150-FF	3	4,6	188



Page / path	1.0	1.1	1.1	1.1	1.1	1.1	1.1	1.1	1.1	1.1	4.1	4.1	4.1	5.1	4.1	5.1	4.1	5.1	4.1	5.1	4.35:09	5.35:09
-------------	-----	-----	-----	-----	-----	-----	-----	-----	-----	-----	-----	-----	-----	-----	-----	-----	-----	-----	-----	-----	---------	---------

Cable designation	
Cable type	1.5mm <sup>2</sup> 2x or
Connection	X
Destination	X

Terminal strip designation	Terminal name	Terminal number	Connection	Destination
	PE	1		PE
	1F1	2		1F1
	1F1	3		1F1
	1F1	4		1F1
	1F1	5		1F1
	N	6	L/3	1T1
	2N1	7	L	X1
	1T1	8		X1
	1F1	9		X1
	1F1	10		X1
	PE	11		PE
	PE	12		PE
	PE	13		PE

Cable designation	Cable type	Connection	Destination
M6	YSLY-JZ 4x1.5mm <sup>2</sup>	X4	
M9	YSLY-JZ 4x1.5mm <sup>2</sup>	1	

Function	Destination
main supply PE	main supply PE
main supply L1	main supply L1
main supply L2	main supply L2
main supply L3	main supply L3
main supply N	main supply N
voltage supply fresh air motor L1	voltage supply fresh air motor L1
voltage supply extracted motor L1	voltage supply extracted motor L1
voltage supply fresh air motor L2	voltage supply fresh air motor L2
voltage supply extracted motor L2	voltage supply extracted motor L2
voltage supply fresh air motor L3	voltage supply fresh air motor L3
voltage supply extracted motor L3	voltage supply extracted motor L3
voltage supply fresh air motor PE	voltage supply fresh air motor PE
voltage supply extracted motor PE	voltage supply extracted motor PE

Page / path	0	1	2	3	4	5	6	7	8	9
Terminal strip designation	Cable designation									
	Cable type									
	Connection									
	Destination									
	Terminal name									
	Terminal number	1	2	3	4	5	6	7	8	9
	Connection	3N1	3N1	3N1	3N1	3N1	3N1	3N1	3N1	3N1
	Destination									
	Cable type	3N1	3N1	3N1	3N1	3N1	3N1	3N1	3N1	3N1
	Connection	3N1	3N1	3N1	3N1	3N1	3N1	3N1	3N1	3N1
X2	Cable designation									
	Cable type									
	Connection									
	Destination									
	Terminal name									
	Terminal number	10	11	12	13	14	15	16	17	18
	Connection	3N1	3N1	3N1	3N1	3N1	3N1	3N1	3N1	3N1
	Destination									
	Cable type	3N1	3N1	3N1	3N1	3N1	3N1	3N1	3N1	3N1
	Connection	3N1	3N1	3N1	3N1	3N1	3N1	3N1	3N1	3N1
Function	Cable designation									
	Cable type									
	Connection									
	Destination									
	Terminal name									
	Terminal number	1	2	3	4	5	6	7	8	9
	Connection	3N1	3N1	3N1	3N1	3N1	3N1	3N1	3N1	3N1
	Destination									
	Cable type	3N1	3N1	3N1	3N1	3N1	3N1	3N1	3N1	3N1
	Connection	3N1	3N1	3N1	3N1	3N1	3N1	3N1	3N1	3N1

# Bill of materials

MUP0001E 01.03.1994

Item designation	Amount	Designation	Type number	Supplier	Article number
<b>Hardware:</b>					
drawer steel plate	1	1		TRDX	
X-Cube Control Master	1	3M1		TRDX	A00000027516
transformer PMR	1	1F1		TRDX	A00000027522
WR6-controller	1	2M1		TRDX	A00000027521
Mod-Bus cable connector	1	2N2		TRDX	A00000027528
plug sensor	1	2X1		Wieland	6ST1513S
plug supply pipe	1	1X1		Wieland	76.352.0736.0
circuit breaker 3po.C16A	1	1F1		Siemens	5SY4316-7
safaty clip	2	1F2/1F3		Weidmüller GmbH & Co.	ASK 1/35
micro fuse 2.5A T 5x20mm	1	1F2		Sonepar	
micro fuse 6.3A T 5x20mm	1	1F3		Sonepar	
DIN rail TS95	50cm			Licatec	
cable 5x1.5mm <sup>2</sup>	60cm	cable supply pipe		Sonepar	YSLY-JZ 3x1.5mm <sup>2</sup>
cable 3x0.75mm <sup>2</sup>	40cm	cable sensory		Sonepar	YSLY-JZ 3x0.75mm <sup>2</sup>
cable duct 20x60mm	75cm			Licatec	
snap in clamp	1			DBD	2105 012
AWM Modular-Stecker	6			Sonepar	1290053
telefoncabel 6-core flat	120cm			Sonepar	1209571
raised head screw 4x20mm	4			van Beusekom	
raised head screw 4x4mm	15			van Beusekom	
network cable 1.5m	1			Sonepar	

Date		08.08.16		drawer		draw. -No. : 12-1002A	
Editor		JK		MSR 400AC		=	
Tested		08.08.16		Original		+	
Name		5.7D		Sub. f.		R28141	
Norm				Sub. b.			
				X-Cube C/R		bill of materials	
				(L)/R/20/30/42/52		part 1	
				CUBE compact			
Changes				Date		P.	
						8	
						9 P.	



## G Accessories for X-CUBE compact



Installation and commissioning manual

GB/en

# Accessories

for X-CUBE compact units



**TROX<sup>®</sup>** TECHNIK  
The art of handling air

Read the instructions prior to performing any task!

TROX GmbH  
Heinrich-Trox-Platz  
47504 Neukirchen-Vluyn, Germany  
Germany  
Telephone: +49 2845 202-0  
Fax: +49 2845 202-265  
E-mail: trox-de@troxgroup.com  
Internet: www.trox.de

A00000050839, 5, GB/en  
03/2021

© TROX GmbH 2015

<b>1</b>	<b>Overview .....</b>	<b>4</b>
1.1	Compact units and standard components .....	4
1.2	Accessories .....	5
<b>2</b>	<b>Setting the bus address for accessories .....</b>	<b>7</b>
<b>3</b>	<b>Establishing the bus communication .....</b>	<b>8</b>
<b>4</b>	<b>Deactivating accessories .....</b>	<b>11</b>
	<b>Appendix.....</b>	<b>13</b>
A	Connection diagrams .....	14
A.1	XCC-HM .....	14
A.2	XCC-HCM .....	16
A.3	XCC-CM .....	18
A.4	XCC-EHD .....	20
A.5	XCC-CD-RA .....	23
A.6	XCC-CD-RD .....	24
A.7	XCC-CPC .....	25
A.8	XCC to TNC EASYCONTROL .....	26

Overview



Compact units and standard components

1 Overview

1.1 Compact units and standard components

Image	Code	Description
	X-CUBE-C-R(L)-P/xxxx	X-CUBE compact with counter flow plate heat exchanger
	X-CUBE-C-R(L)-R/xxxx	X-CUBE compact with rotary heat exchanger
	XCC-ST	Touch panel
		Modbus connecting cable (RJ12)



**1.2 Accessories**

Image	Code	Description
	XCC-HM	Heating coil module including XCC-CB1 module
	XCC-HCM	Heating/cooling coil module (hot water/chilled water system) including XCC-CB2 module
	XCC-CB 1	Controls module with connections for: Heating coil module XCC-HM, heat exchanger, evaporator
	XCC-CB 2	Controls module with connections for: Heating/cooling coil module XCC-HCM, heater/steam humidifier module
	XCC-HD	Heating coil (hot water system) for rectangular ducts, with integral capillary tube thermostat for frost protection
	XCC-EHD	Electric duct air heater for rectangular ducts
	XCC-CD-RA	Control panel, analogue

## Overview

Accessories

Image	Code	Description
	XCC-CD-RD	Control panel, digital
	XCC-S-...	<p>Sensors</p> <ul style="list-style-type: none"> <li>■ XCC-S-TD: Temperature sensor for ventilation ducts</li> <li>■ XCC-S-CO2VOC: Combined CO<sub>2</sub> / VOC sensor for ventilation ducts</li> <li>■ XCC-S-TCO2HR: Room temperature, CO<sub>2</sub> (shown)</li> </ul>
	XCC-CPC	Parts kit for pressure-based control (constant pressure)
	XCC-P	Circulator pump
	XCC-V	Valve assembly for the hydraulic connection of heating and cooling coils

## 2 Setting the bus address for accessories



Fig. 1: Extension Module

① Rotary button for setting the address

**The Extension Module is an integral part of the controls module XCC-CB; the number of modules varies depending on the type of controls module:**

- XCC-CB1 - 1 Extension Module
- XCC-CB2 - 2 Extension Modules

### Address settings

Accessories	Controls module / type	Address	Supply voltage to be provided by others
Heating coil	XCC-CB-1	3	×
Cooling coil	XCC-CB-1	4	×
Heating coil / cooling coil	XCC-CB-2	Heating coil: 3 (Extension Module on the right)	×
		Cooling coil: 4 (Extension Module on the left)	
Electric duct air heater	XCC-EHD	5	×
Evaporator	-	7	×
Preheater (electric or hot water)	XCC-CB-1/XCC-EHD	8	×
Constant pressure control	XCC-CPC	0 (supply air), 1 (extract air)	–
Digital control panel	XCC-CD-RD	Is automatically recognised	–

## Establishing the bus communication



### 3 Establishing the bus communication

Cable entry points on the X-CUBE compact



Fig. 2: Cable entry points below the mains isolator

- ① Mains isolator
- ② Bus connection, input/output
- ③ Bus connection, input/output
- ④ Service interface of touch panel
- ⑤ Service interface of TCP/IP network
- ⑥ Fault messages etc.
- ⑦ Main connection of unit (voltage supply)
- ⑧ Signal line, e.g. for faults

#### ! NOTICE!

##### Risk of damage to property from incorrect use

The service interfaces of the touch panel ( Fig. 2 /4) and TCP/IP network ( Fig. 2 /5) are intended for temporary use (e.g. service).

When not in use, protect the service interfaces from the weather by fitting caps.

If the device is used for a long period of time, it may be damaged by moisture, especially if it is installed outdoors.

The permanent and professional installation of the bus connecting cables is carried out at the inputs and outputs of the control master using the existing cable penetrations as cable glands.

#### Connecting the compact unit and accessories to the bus cable

##### Personnel:

- Skilled qualified electrician

#### ⚠ DANGER!

For wiring the components, comply with the requirements and safety notes in the 'X-CUBE compact transport and installation manual'.

For more information on wiring refer to the electric circuit diagram for the compact unit.

**Prerequisite:** The compact unit and accessories have been installed and connected to the power supply network.

#### Switching off the power supply

#### ⚠ DANGER!

Danger of electric shock! Do not touch any live components! Electrical equipment carries a dangerous electrical voltage.

- Only skilled qualified electricians are allowed to work on the electrical system.
- Switch off the power supply before working on any electrical equipment.

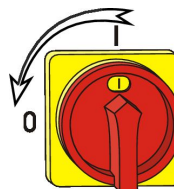

Fig. 3: Switching off the mains isolator

1. ▶ Turn the mains isolator on the compact unit to 0/OFF.
2. ▶ Switch off the power supply on the accessory you want to connect and secure it against being switched on accidentally.

Connecting the communication cable

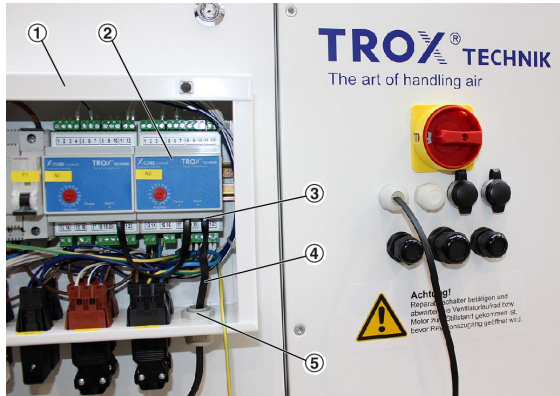

Fig. 4: Controls module

3. ▶ Open the cover of the controls module ( Fig. 4 /1) and set the address of the accessory on the Extension Module ( Fig. 4 /2) ↪ on page 7 .

Take the supplied bus connecting cable (RJ12, Fig. 4 /4) and feed it through the cable entry point in the casing of the controls module ( Fig. 4 /5) into the controls module.

Plug the bus connecting cable into the RJ12 socket ( Fig. 4 /3) on the Extension Module.

For two Extension Modules (XCC-CB-2) it is sufficient to connect the bus cable only once with the control master as all extension modules are interconnected, and the signals are transmitted from one module to the next.

4. ▶ Close the cover of the controls module.



Fig. 5: Removing the electrical connections panel

5. ▶ Loosen the screws ( Fig. 5 /2) on the electrical connections panel ( Fig. 5 /1) and remove the panel.

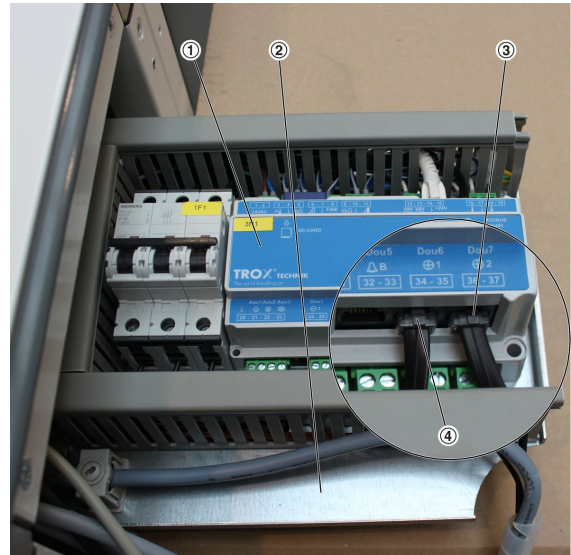

Fig. 6: X-CUBE control master

6. ▶ To connect the bus cable to the control master ( Fig. 6 /1), pull out the tray with the electrical components ( Fig. 6 /2).

Feed the bus connection cable through the cable entry point ( Fig. 2 /2) in the panel and plug it into port C (RJ12 socket, Fig. 6 /3) of the control master.

If port C is already used, plug the connection cable into port B (RJ12 socket, Fig. 6 /4).

Lay the bus connection cable in such a way that it will not be damaged when you mount the panel again.

Push the tray with the electronic components back into the unit.

7. ▶ Mount the electrical connections panel ( Fig. 5 /1).

## Establishing the bus communication



### Activating accessories



- 8. ▶ Use the supplied bus cable to connect the touch panel to the corresponding cable entry point ( Fig. 2 /4).
- 9. ▶ Switch on the power supply for the accessory.

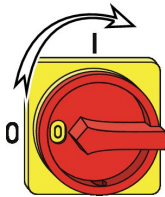

- 10. ▶ Turn the mains isolator of the compact unit to I/ON



- 11. ▶ Use the touch panel to activate accessories. For details on using the touch panel refer to the X-CUBE compact operating manual.

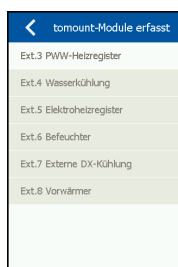

- 12. ▶ The unit recognises connected accessories automatically. After approx. 5-30 s a message is displayed on the touch panel (example shown).



- 13. ▶ Enter your password and confirm it with ✓.

Default password: 0022

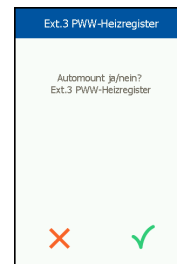

- 14. ▶ To activate the accessory, press ✓.

⇒ Once an accessory has been activated, you can configure it. For details refer to the X-CUBE compact operating manual.

## 4 Deactivating accessories

Use the touch panel to deactivate accessories. For details on using the touch panel refer to the X-CUBE compact operating manual.



1. ▶ Select the 'Menu'.

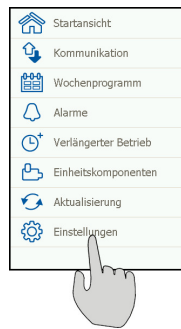

2. ▶ Select 'Settings'.

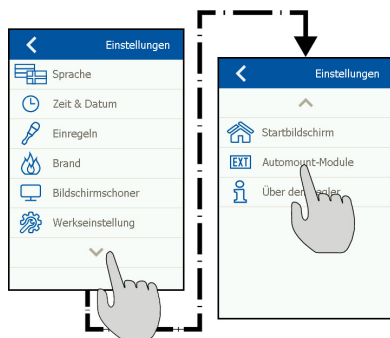

3. ▶ Select the arrow to display more settings, then select 'Automount modules'.



4. ▶ Select the accessory you want to deactivate.



5. ▶ Enter your password and confirm it with ✓.

Default password: 0022

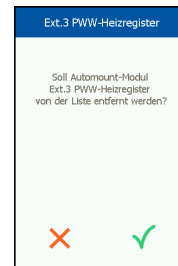

6. ▶ Press ✓ to deactivate the accessory.  
⇒ The accessory is now no longer active.

Deactivating accessories



**Appendix**

Connection diagrams



**A Connection diagrams**  
**A.1 XCC-HM**

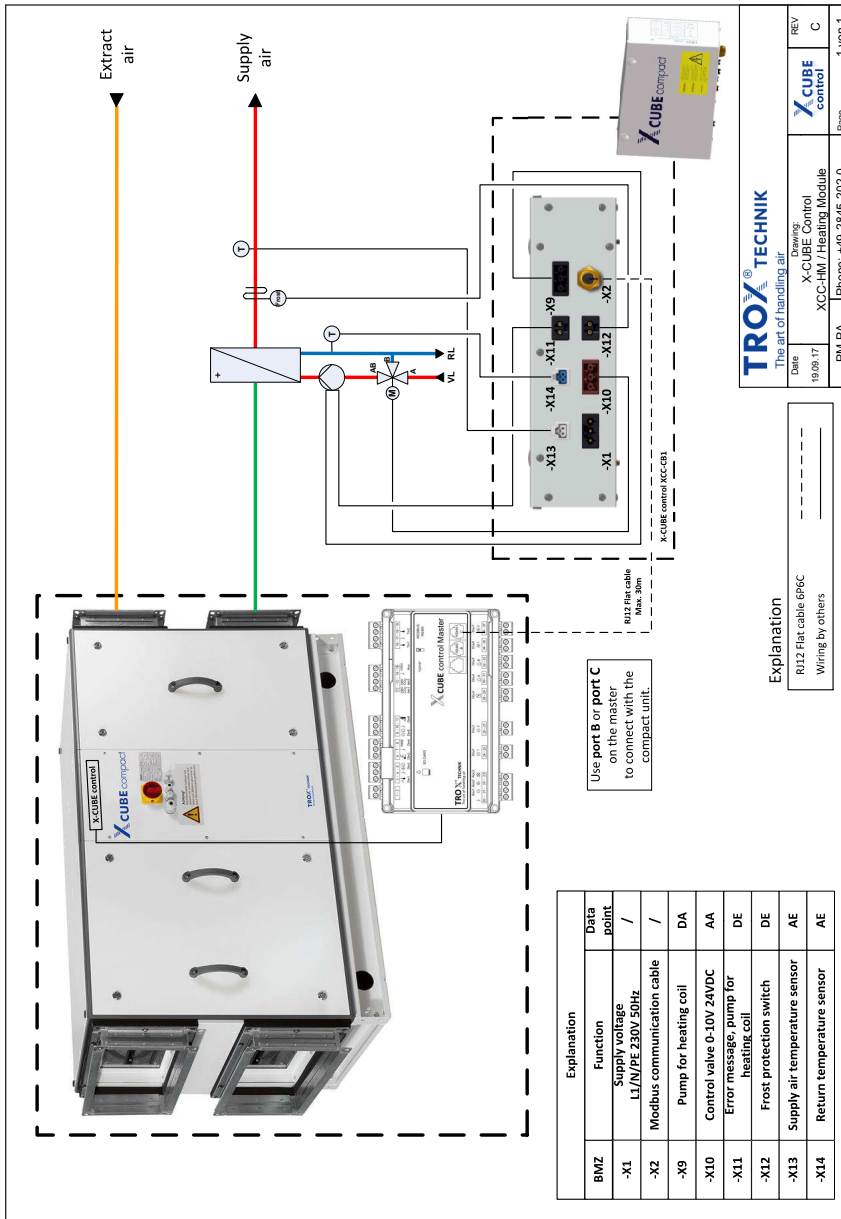

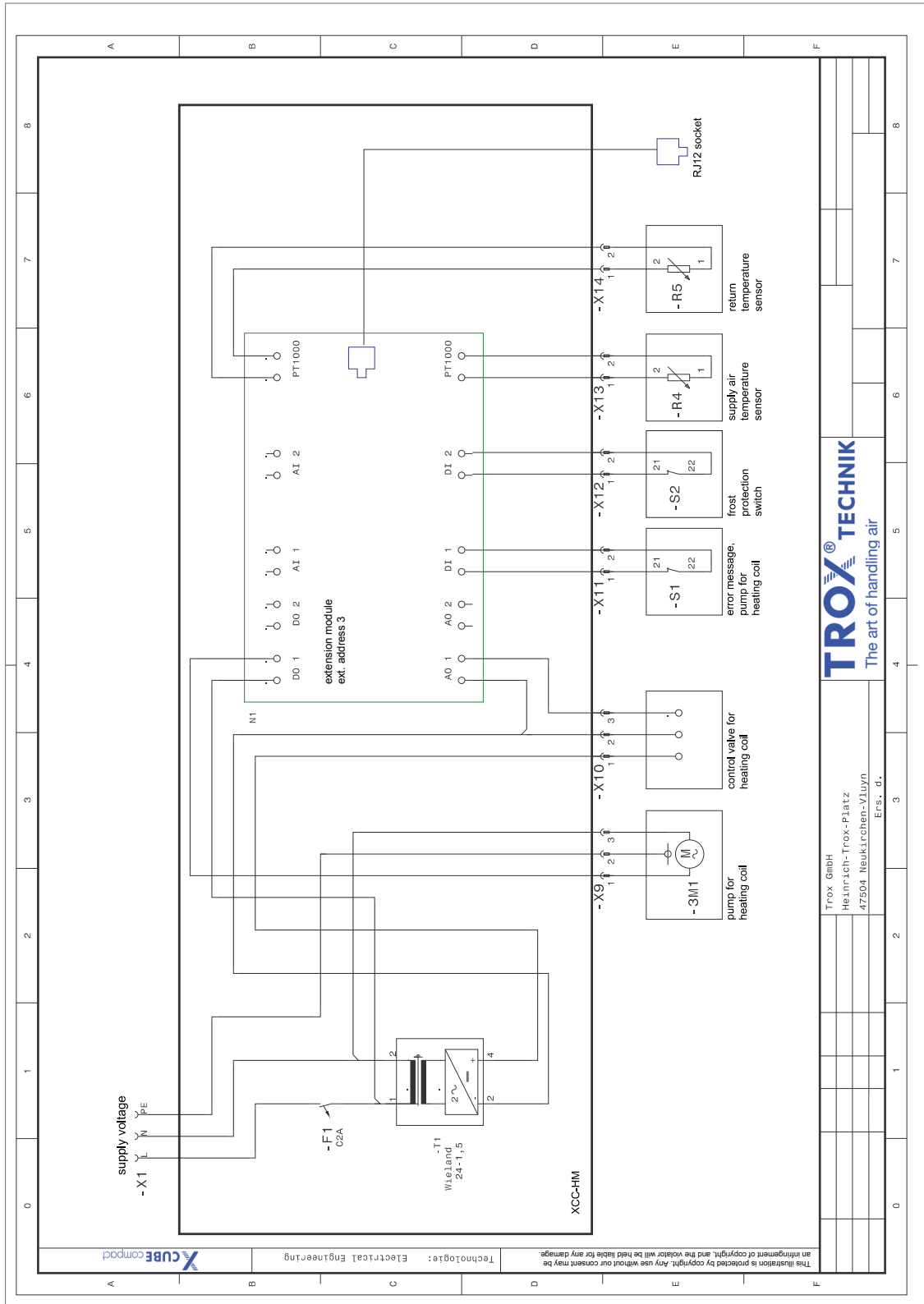

TROX® TECHNIK  
The art of handling air

Trox GmbH  
Heinrich-Trox-Platz  
47504 Neukirchen-Vluyn  
Ers. d.

X-CUBE compact

Electrical Engineering

This illustration is protected by copyright. Any use without our consent may be an infringement of copyright, and the violator will be held liable for any damage.

## Connection diagrams



### A.2 XCC-HCM

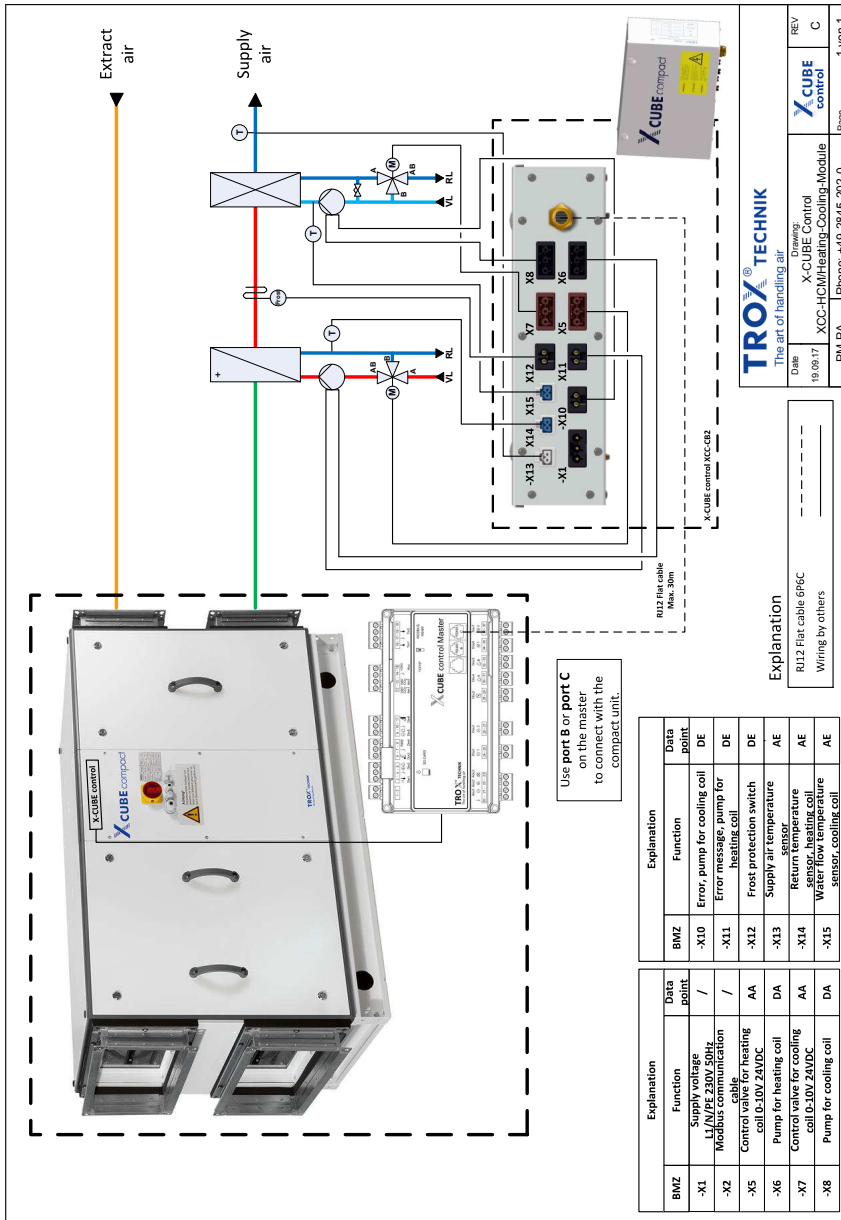

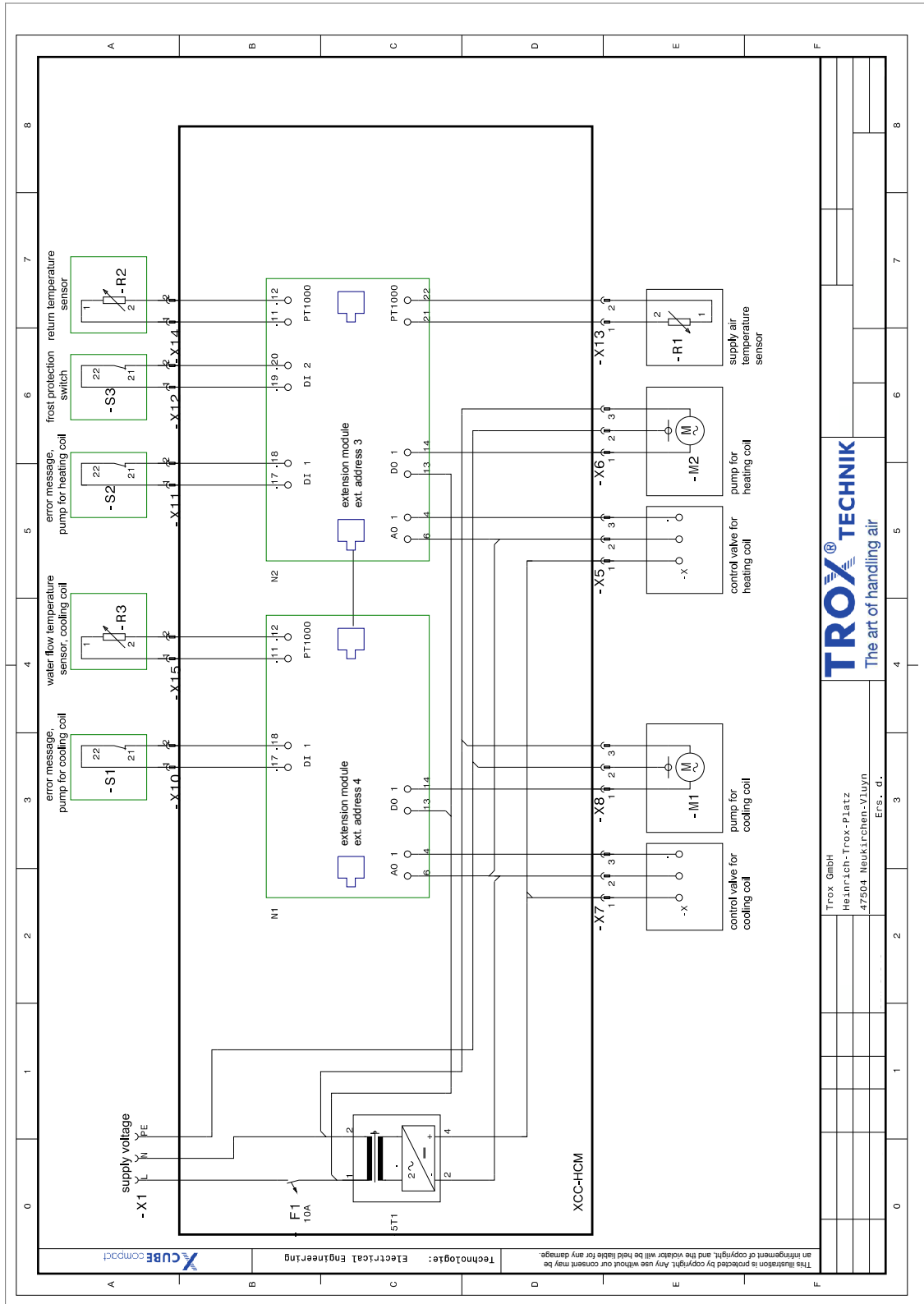

Connection diagrams

A.3 XCC-CM

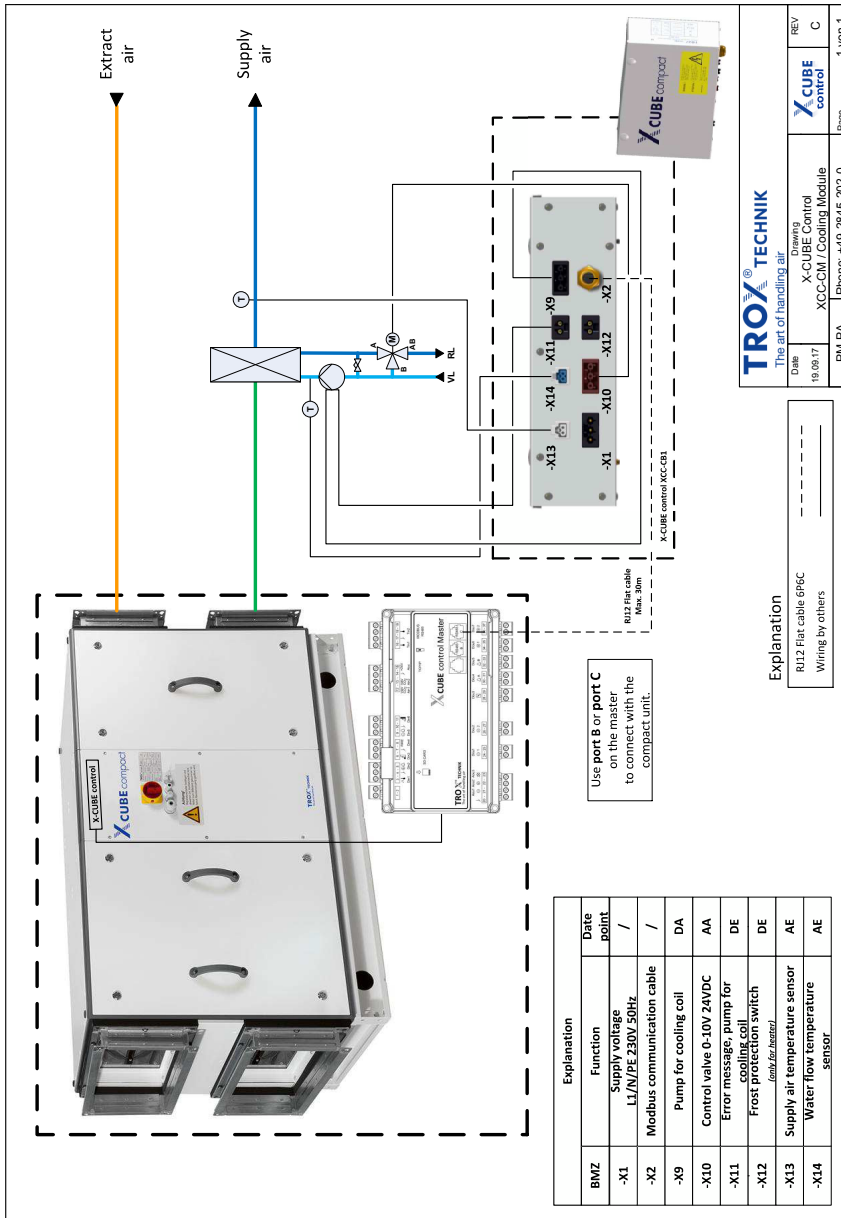

TROX® TECHNIK The art of handling air	
Date	19.09.17
Rev.	C
Product	X-CUBE control
Module	XCC-CM / Cooling Module
Phone	+49-2845-202-0
Page	1 von 1

**Explanation**  
 RJ12 Flat cable 6P6C  
 Wiring by others

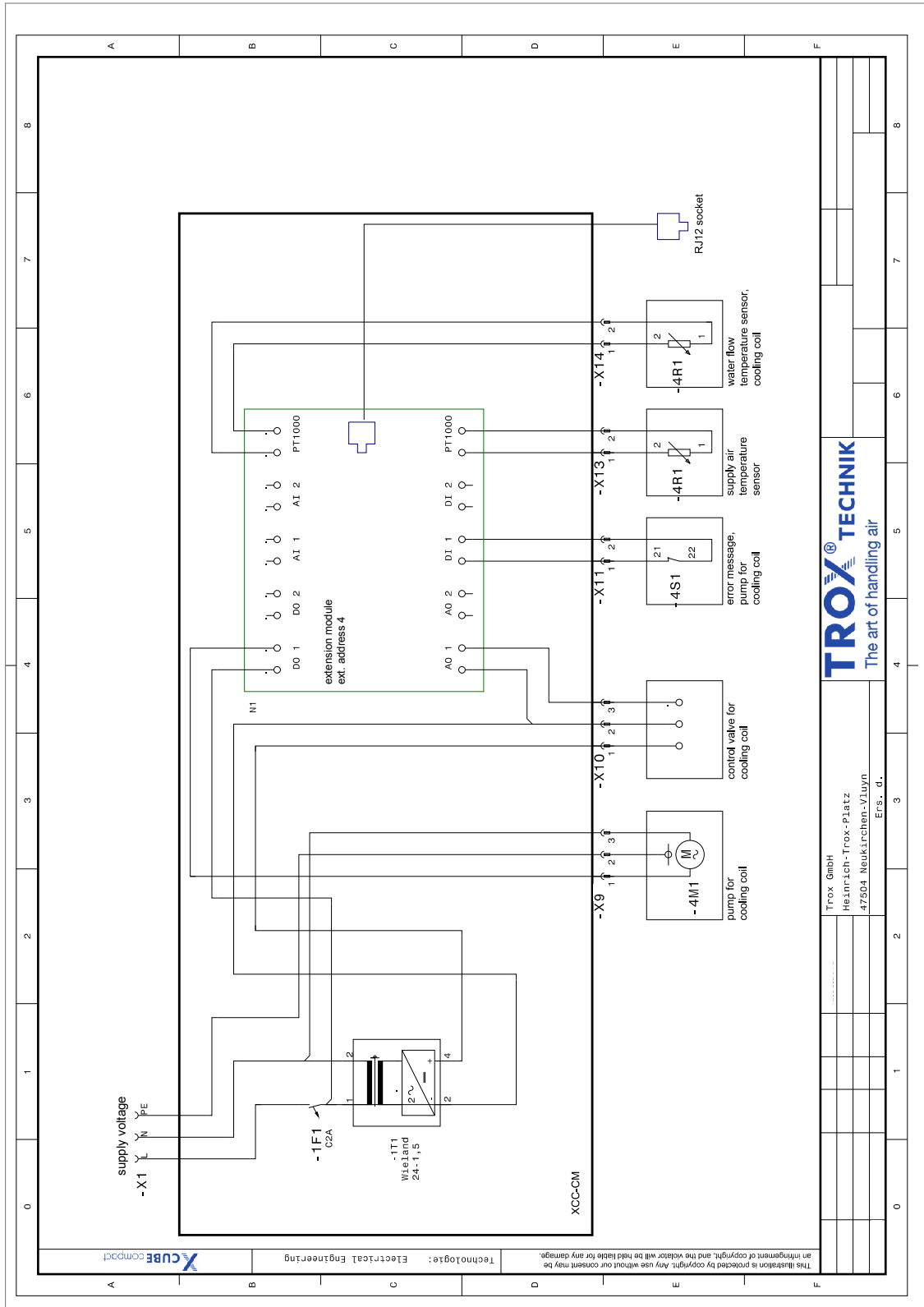

## Connection diagrams

### A.4 XCC-EHD

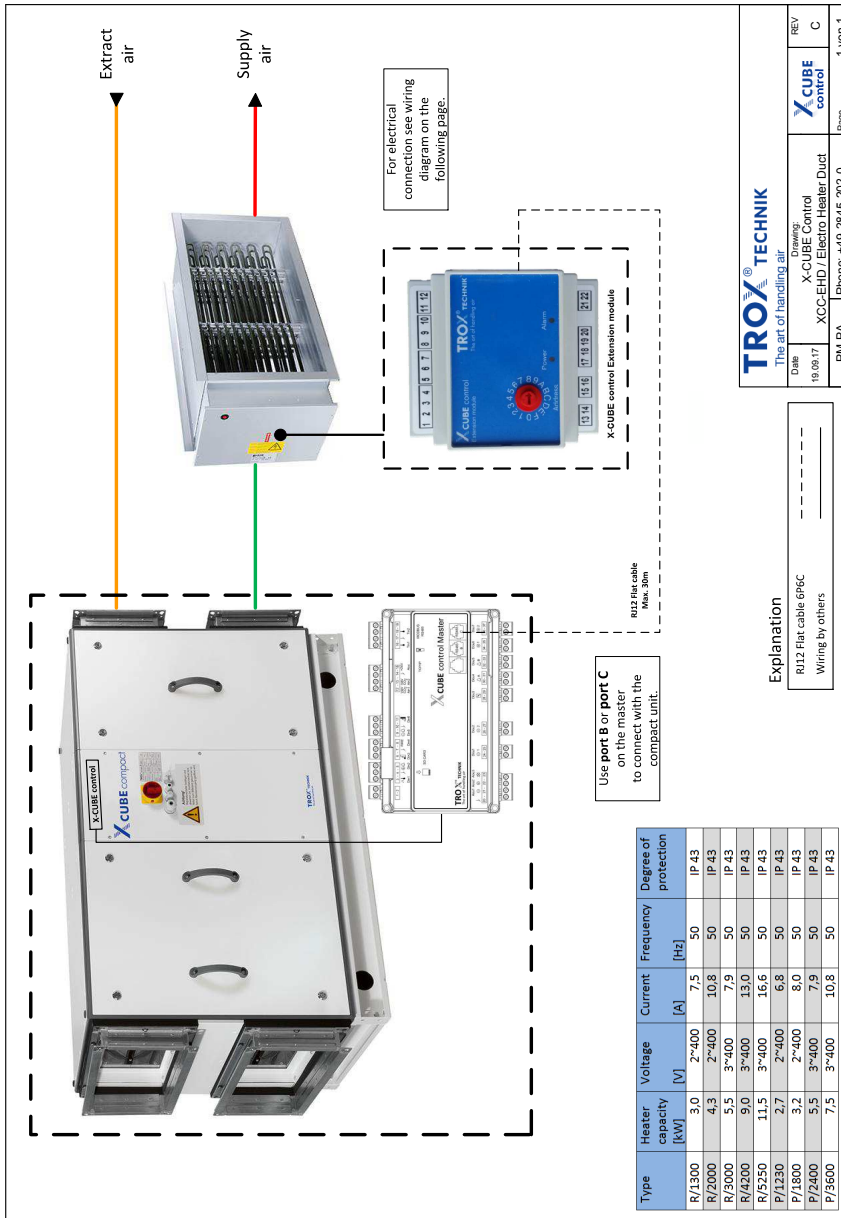



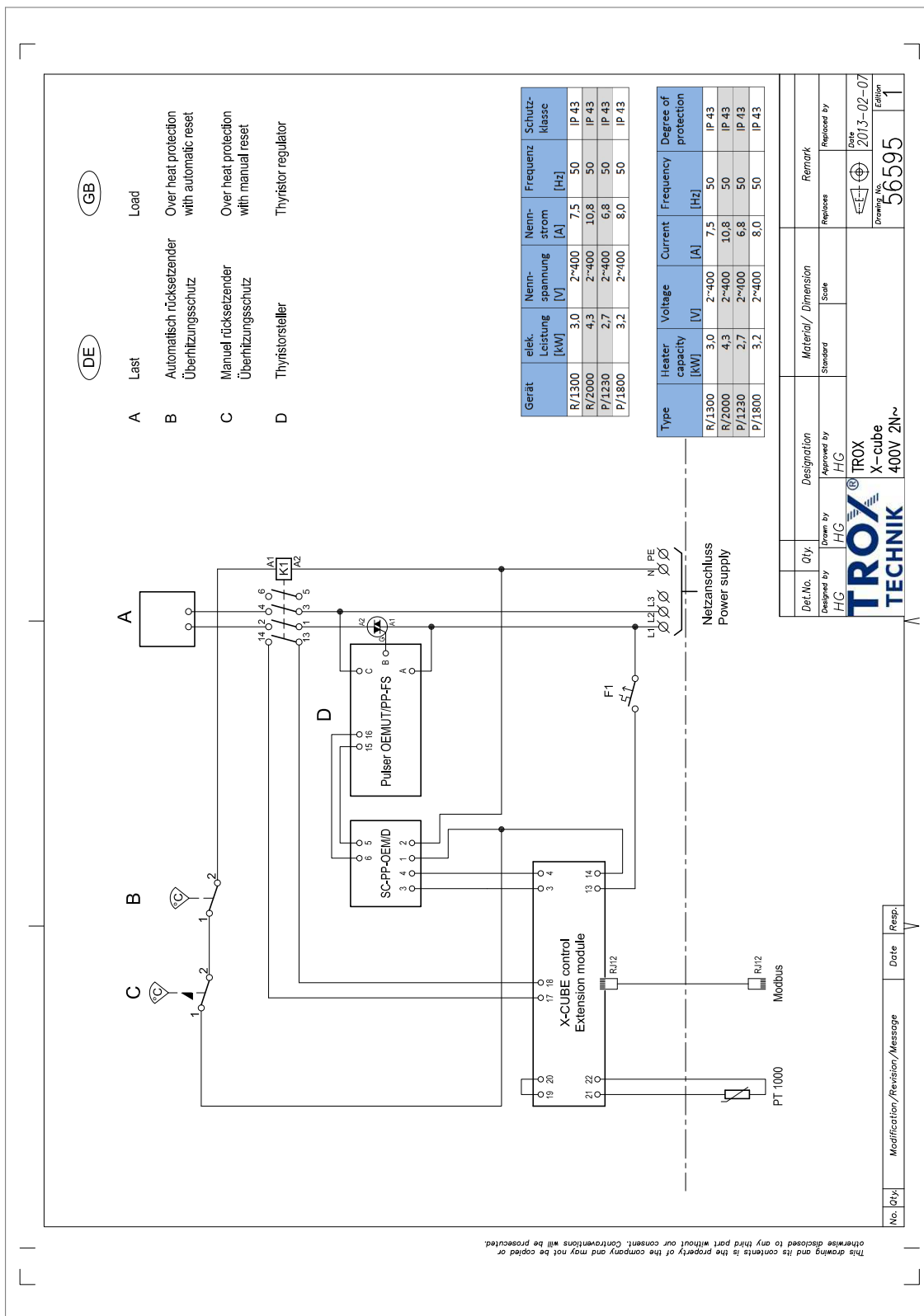

## Connection diagrams



(GB)

- A Last ≤40A
- B Automatisch rücksetzender Überhitzungsschutz
- C Manuel rücksetzender Überhitzungsschutz
- D Thyristorsteller

(DE)

- A Last ≤40A
- B Automatisch rücksetzender Überhitzungsschutz
- C Manuel rücksetzender Überhitzungsschutz
- D Thyristorsteller

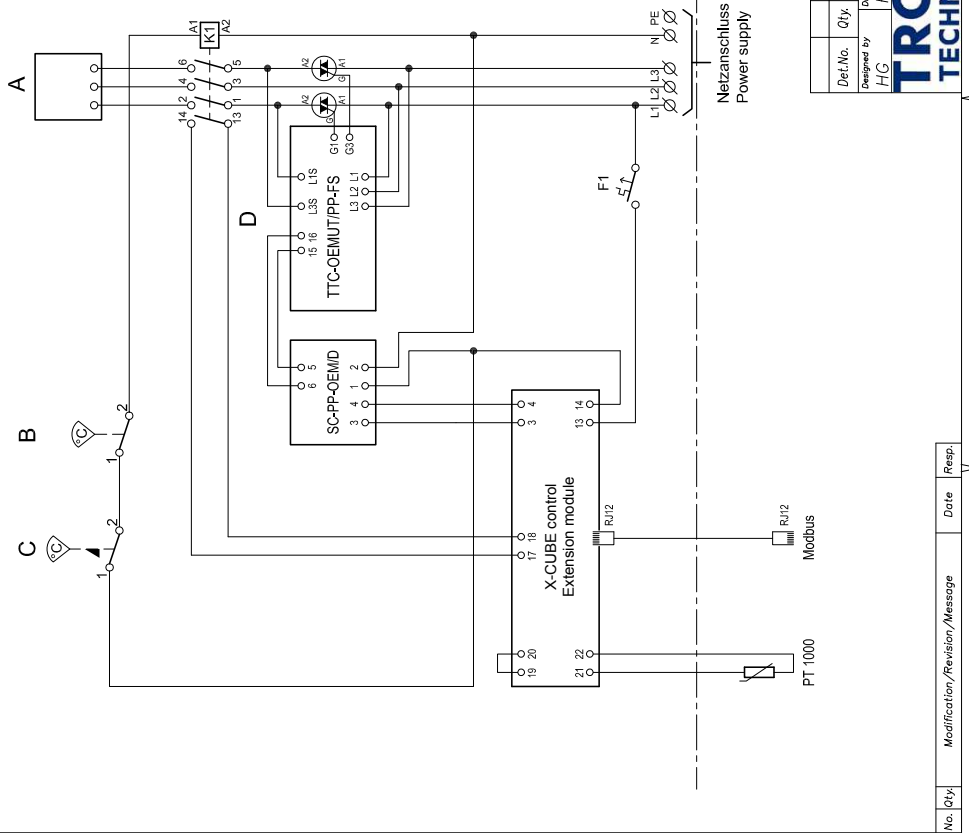

Gerät	elek. Leistung [kW]	Nennspannung [V]	Nennstrom [A]	Frequenz [Hz]	Schutzklasse
R/3000	5.5	3~400	7.9	50	IP 43
R/4200	9.0	3~400	13.0	50	IP 43
R/5250	11.5	3~400	16.6	50	IP 43
P/2400	5.5	3~400	7.9	50	IP 43
P/3600	7.5	3~400	10.8	50	IP 43

Type	Heater capacity [kW]	Voltage [V]	Current [A]	Frequency [Hz]	Degree of protection
R/3000	5.5	3~400	7.9	50	IP 43
R/4200	9.0	3~400	13.0	50	IP 43
R/5250	11.5	3~400	16.6	50	IP 43
P/2400	5.5	3~400	7.9	50	IP 43
P/3600	7.5	3~400	10.8	50	IP 43

Det.No.	Qty.	Designation	Material/ Dimension	Remark
HG	HG	Approved by	Scale	Replaced by
HG	HG	Designed by	Standard	Replaced by
TROX® TECHNIK		X-cube 400V 3N~ ... 40A		Date 2013-11-06
Drawing No.		56596		Edition 1

This drawing and its contents is the property of the company and may not be copied or otherwise disclosed to any third party without our consent. Contrventions will be protected.

A.5 XCC-CD-RA

Xcube Control Wiring

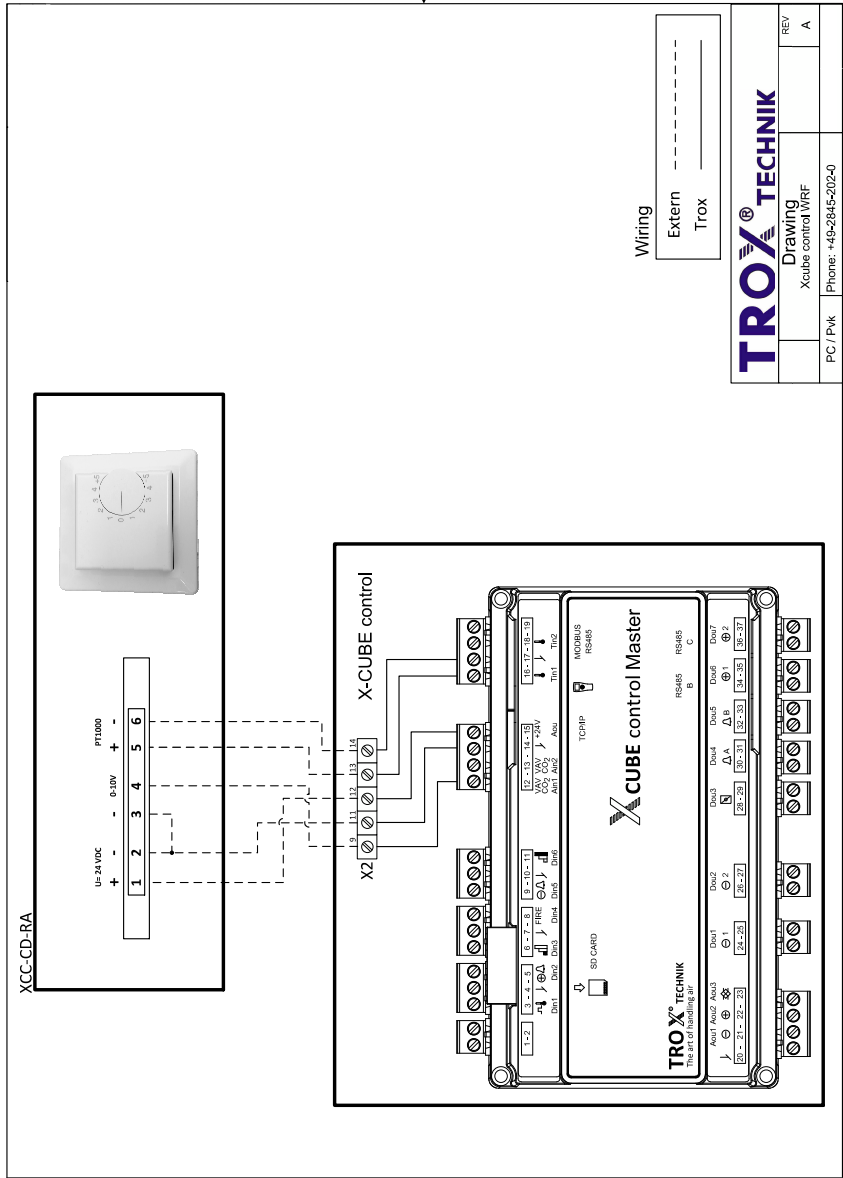

Wiring  
 Extern -----  
 Trox \_\_\_\_\_

**TROX® TECHNIK**

PC / Pvk	REV
Drawing	A
Xcube control WRF	
Phone: +49-2945-202-0	

## Connection diagrams



### A.6 XCC-CD-RD

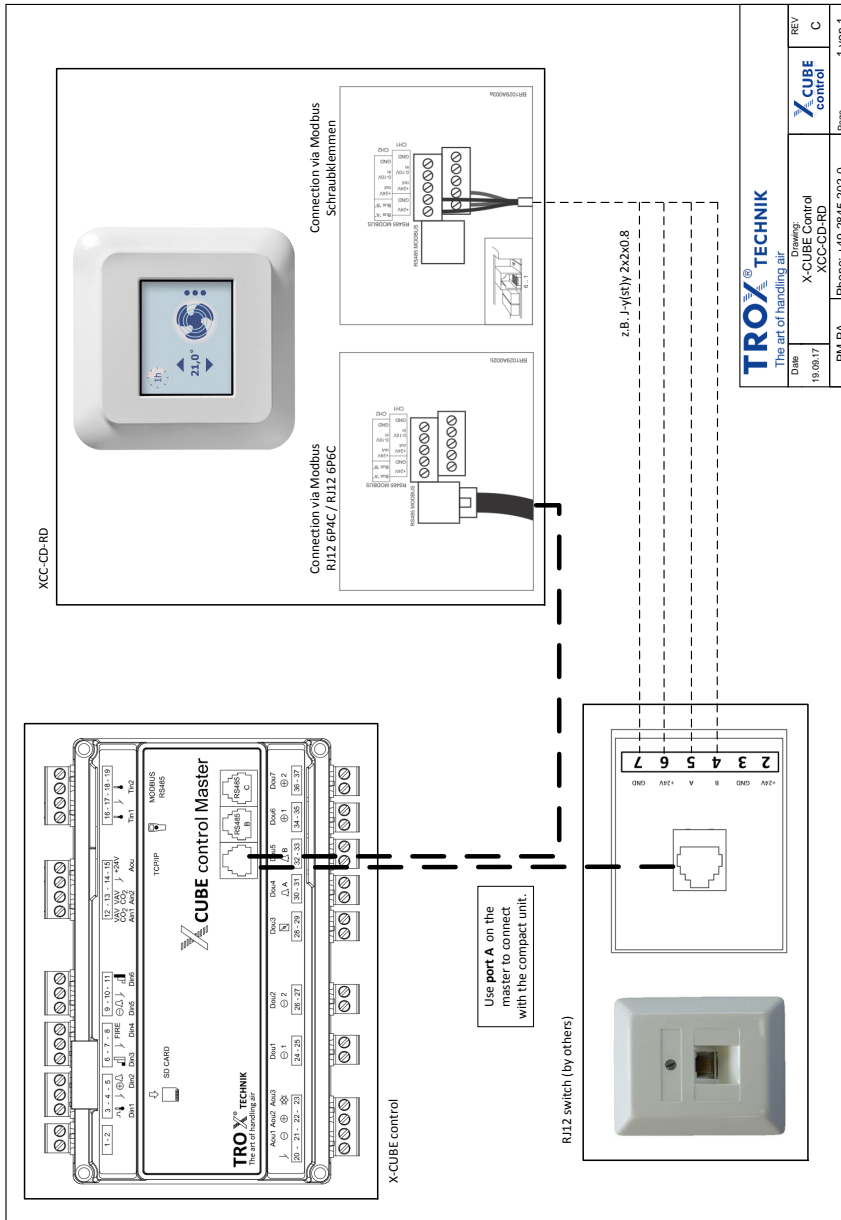

**TROX® TECHNIK**  
The art of handling air

Date	18.09.17	REV	C
Product	X-CUBE control	Product	X-CUBE control
Part No.	XCC-CD-RD	Page	1 von 1
Phone	+49-2816-202-0		

A.7 XCC-CPC

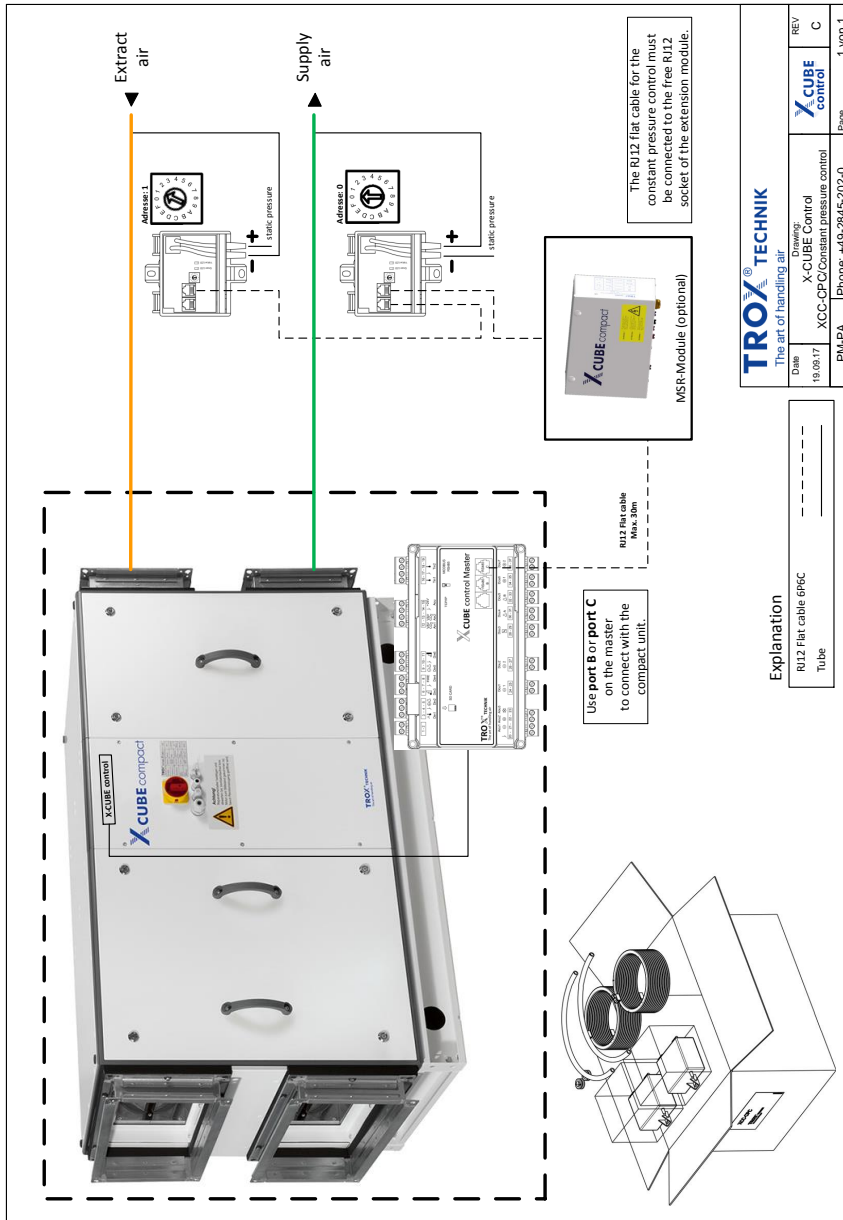

Connection diagrams



A.8 XCC to TNC EASYCONTROL

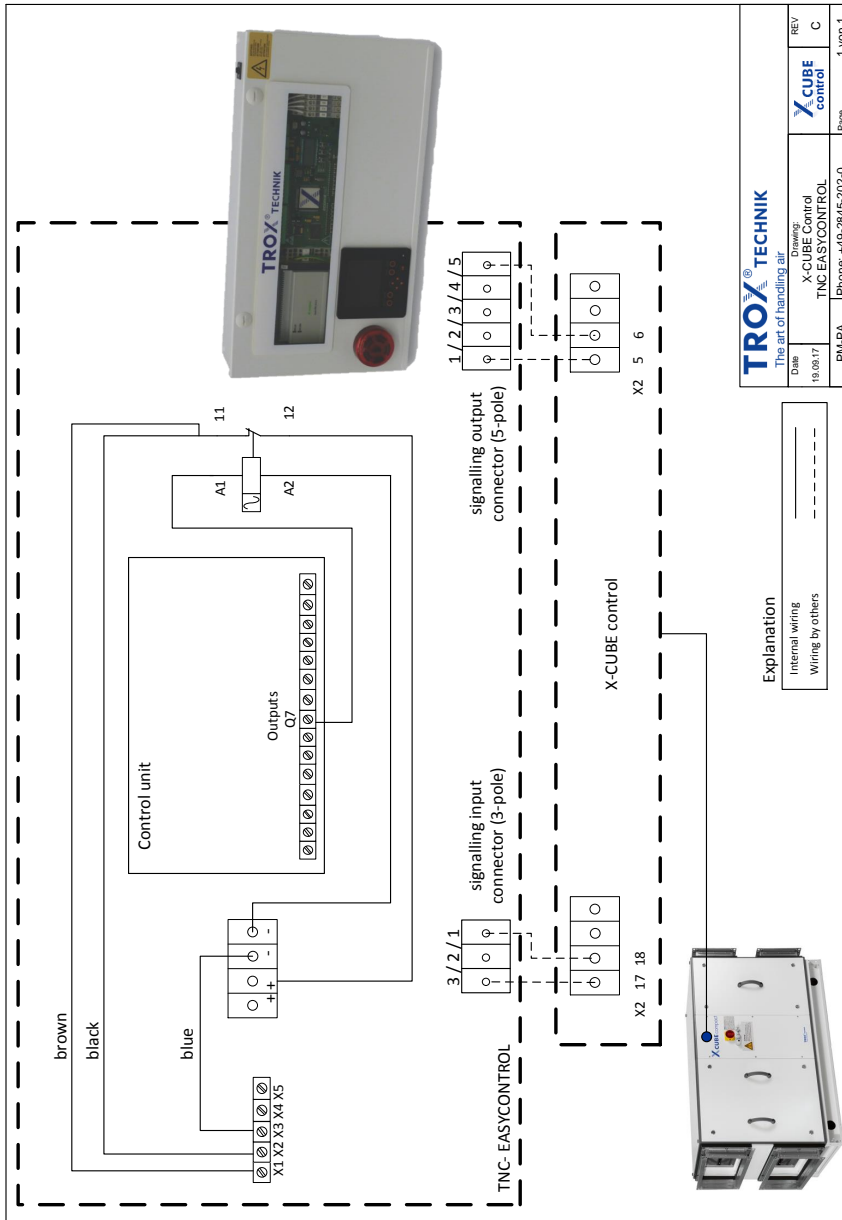

TROX<sup>®</sup> TECHNIK  
The art of handling air

Date	19.09.17	REV	C
Drawn by	X-CUBE control	Page	1 von 1
Checked by	TNC EASYCONTROL	Product	X-CUBE control
Phone: +49-2816-202-0			

Explanation  
Internal wiring  
Wiring by others

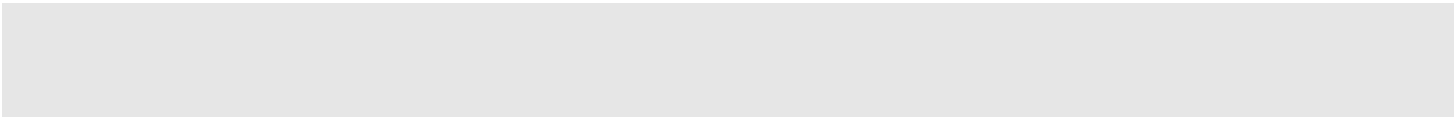

# TROX<sup>®</sup> TECHNİK

The art of handling air

TROX GmbH  
Heinrich-Trox-Platz  
47504 Neukirchen-Vluyn, Ger-  
many

Germany  
+49 2845 202-0  
+49 2845 202-265  
E-mail: [trox-de@troxgroup.com](mailto:trox-de@troxgroup.com)  
[www.trox.de](http://www.trox.de)

© TROX GmbH 2015